

**Rules and Regulations
for
Electric Service**

**January 2021
Edition**

(This page left blank)

INTRODUCTION

JEA makes every effort to provide high quality, safe and reliable electric service to all customers. Providing such service requires that rational rules and guidelines be established, fairly administered, and clearly understood by all concerned. This publication has been prepared with this in mind and should be helpful to customers, architects, engineers, electrical contractors and local inspection authorities relative to the installation of new electric facilities and the upgrade of existing facilities.

The requirements in this booklet supplement and complement those of the National Electrical Code (NEC), the National Electrical Safety Code (NESC), and the applicable codes and ordinances of state, county and municipal authorities. A number of requirements within these various codes are not always consistent. In such areas of conflict, JEA will follow the requirements of the NESC, which has been adopted by the Florida Public Service Commission as minimum design standards for electric utilities in the State of Florida.

Such codes, for the most part, set forth only those requirements consistent with safety. The NEC states: "Compliance therewith and proper maintenance will result in an installation essentially free from hazard but not necessarily efficient, convenient or adequate for good service or future expansion of electrical use". Therefore, it is recommended that the customer consider installation of facilities exceeding the minimum requirements in order to protect building investment and improve the potential for energy efficiency.

(This page left blank.)

SUMMARY OF CHANGES

January 1, 2021

The vertical bars on each page denote the areas that have been revised.

CHAPTER I GENERAL CUSTOMER INFORMATION:

A. Section 1.14, Requirements for Disconnecting Electric Service:

Moved:

- Fraudulent representation in relation to the consumption of current amount or the securing of same.
- Suspected illegal or unsafe wiring.
- Using electricity without making proper application.
- Unauthorized use of electricity.
- Violation of Section 812.14, Florida State Statute (trespass and larceny with relation to utilities).

CHAPTER II GENERAL SERVICE INFORMATION:

A. Section 2.01, Basic Requirements for Customer's Facility:

Added: ...with the exception of dedicated fire pump services connected at a metered transformer bus.

Replaced: ... either an approved "Rough" inspection or an approved "Final" inspection with an approved "Temporary Final" or "Final" inspection...

B. Section 2.02, Description of Customer's Installation:

Deleted:

For Duval County use form submitted to Electrical Inspection.

For Atlantic Beach and services outside Duval County use Figure 2.01, JEA Service Load Calculation.

For Public Agencies permitting through JEA, use Figure 2.01, JEA Service Load Calculation

Added: See Figure 2.01

C. Section 2.07, Repair and Modification of Existing Services:

Changed: Normal business hours to 7AM – 3:30PM

D. Section 2.16, Generators:

Replaced: Entire section

JEA Rules and Regulations For Electric Service
Summary of Changes

E. Section 2.22, Conductor Identification:

Added: and 4.04B, Conduit/Conductor Installation (Commercial Service 100 Amp Maximum) – UG Service from OH Pole;

CHAPTER IV SECONDARY METERED SERVICES – UNDERGROUND (0-600V):

A. Section 4.03, New Underground Developments:

Clarified: Service lateral requirements

B. Section 4.04, Service Laterals in Underground Residential/Apartment Developments:

Clarified: Duplex requirements

C. Section 4.05, Commercial Services from Padmounted Transformers:

Added: NOTE: On new transformer installs the secondary conductor shall not be installed in conduit until the JEA transformer has been placed on the pad.

D. Section 4.08, Underground Service from Overhead Pole: Residential/Commercial

Added: EXCEPTION: Commercial Services, 100 Amps or less will be installed as outlined in Figure 4.04B, Conduit/Conductor Installation (Commercial Service 100 Amp Maximum) – UG Service from OH Pole.

CHAPTER V DOWNTOWN UNDERGROUND SECONDARY SERVICES:

A. Section 5.08, Customer’s Responsibility to Maintain Spot-Network Transformer Vault:

Added: The customer is responsible to provide 24 hour 7 day a week access for maintenance, emergency and/or routine work. JEA will provide a mortise-type lock for egress doorway, holders of keys shall be limited to authorized JEA personnel. If possible, the vault door shall directly access the outside of the building.

CHAPTER VII METERS AND METERING EQUIPMENT:

A. Section 7.04, Meter Socket Specifications:

Added: On meter sockets where service neutral conductor is required to be isolated by code and the meter type installed requires a neutral connection, an isolated lug with additional neutral lead tap must be provided for the meter return.

B. Section 7.12, Location of Meters:

Replaced: ...shall provide JEA with keys necessary to access meter rooms. The keys will be kept in a customer installed 4-digit code lockbox, the combination code to be administered by JEA with ...must install a lockbox, in a non-secured JEA-accessible location, that contains a key to the meter room. Lockbox shall be a 4-digit combination

JEA Rules and Regulations For Electric Service
Summary of Changes

type, similar in size and function to Master Lock Safe Space. JEA shall administer the combination to the lockbox.

CHAPTER VIII CUSTOMER UTILIZATION EQUIPMENT:

A. Section 8.02, Voltage Fluctuation Limits:

Added: ...and/or any customer operations that result in rapid changes in either generation or load are shown in the following table. Examples of customer owned equipment that can initiate these voltage fluctuations are provided below in Table 8A.

B. Section 8.11, Harmonics:

Revised: Entire section.

(This page left blank.)

CHANGES TO TABLES
January 1, 2021

TABLE 2A, AVAILABLE SECONDARY SERVICE VOLTAGES:

Added: 120V 1ph 2 wire service

TABLE 8A, VOLTAGE FLUCTUATION LIMITS:

Changed: ...starts per day to ...times per day

(This page left blank.)

CHANGES TO FIGURES: APPENDIX B
January 1, 2021

FIGURE 3.05, TEMPORARY POLE OH SERVICE:

Added: Breaker/disconnect maybe used in place of meter can for qualified TPFRR services.

FIGURE 4.01, RESIDENTIAL SERVICE LATERAL INSTALLATION UG SERVICE (URD & UG SERVICE SIZE FROM OH POLE):

Removed: ...or driveway.

Removed: 6. Pull wire.

FIGURE 4.02, RESIDENTIAL SERVICE LATERAL CONDUIT INSTALLATION UG SERVICE (URD) SERVICE SIZE: 400 AMP MAXIMUM:

Changed: Maximum service size to 400 Amp.

Removed: ...or driveway.

Removed: Illustration of non-standard meter location.

FIGURE 4.03A, TRANSFORMER PAD DETAIL UG SERVICE 75 – 500 KVA 3 PHASE:

Changed: Ground wire requirement.

Added: Measurement from the edge of the pad.

Changed: Maximum of conduits to maximum sets of secondary.

FIGURE 4.03B, TRANSFORMER PAD DETAIL UG SERVICE 750 – 3750 KVA 3 PHASE:

Changed: Ground wire requirement.

Added: Measurement from the edge of the pad.

Changed: Maximum of conduits to maximum sets of secondary.

FIGURE 4.03E, TRANSFORMER PAD DETAIL UG SERVICE 1 PHASE:

Added: Ground rod location. Note: See JEA Underground Construction Standard Manual for Open Delta conduit configuration and wire installation

FIGURE 4.04B, CONDUIT/CONDUCTOR INSTALLATION (COMMERCIAL SERVICE 100 AMP) UG SERVICE FROM OH POLE:

Changed: 200 Amp to 100 Amp.

Removed: Not Available for New Services

JEA Rules and Regulations For Electric Service
Summary of Changes

**FIGURE 4.05, TEMPORARY POLE UG SERVICE, SERVICE SIZE: 400 AMP
MAXIMUM:**

Added: Breaker/disconnect maybe used in place of meter can for qualified TPFPR services.

**FIGURE 4.06, TEMPORARY SERVICE POLE UG SERVICE, SERVICE SIZE: 100
AMP MAXIMUM:**

Added: Breaker/disconnect maybe used in place of meter can for qualified TPFPR services.

Added: (Customer shall remove the temporary service conductor and plug the knock out in the meter can before permanent meter installed)

**FIGURE 7.01A, SELF-CONTAINED METER SOCKET – EXISTING OVERHEAD
SERVICE 1 PHASE 2 WIRE – SERVICE SIZE: 100 AMP MAXIMUM 120V:**

Added: New figure

**FIGURE 7.04, SELF-CONTAINED METER SOCKET – EXISTING OVERHEAD
SERVICE 1 PHASE 3 WIRE 120/208V – SERVICE SIZE: 200 AMP MAXIMUM:**

Added: If isolated neutral is required an isolation kit must be installed to provide a neutral return for the meter (this would be typical with meter on load side of the service disconnecting means). Meter can shall be bonded to the system grounding electrode.

**FIGURE 7.05, SELF-CONTAINED METER SOCKET – UG & EXISTING OVERHEAD
SERVICE 3 PHASE 4 WIRE ALL VOLTAGES – SERVICE SIZE: 200 AMP
MAXIMUM:**

Added: Illustration.

Added: If isolated neutral is required an isolation kit must be installed to provide a neutral return for the meter (this would be typical with meter on load side of the service disconnecting means). Meter can shall be bonded to the system grounding electrode.

**FIGURE 7.09, GROUP METER SOCKET INSTALLATION UG & EXISTING OH
SERVICE – BEHIND BUILDING'S SERVICE EQUIPMENT MAIN:**

Added: Where an isolated neutral is required, the meter can shall be bonded to the system grounding electrode.

**FIGURE 7.12, PREWIRED METER CENTER INSTALLATION UG & EXISTING OH
SERVICE:**

Added: To note 1: (See Section 7.11)

Added: Where an isolated neutral is required, the meter can shall be bonded to the system grounding electrode.

FIGURE 7.12A, JEA SMART METER COMMUNICATION CONDUIT TYP. ALL INTERIOR METER LOCATIONS:

Added: New figure.

(This page left blank.)

TABLE OF CONTENTS

Introduction.....	i
Summary of Changes (January, 2021).....	iii
Changes to Tables (January, 2021).....	vii
Changes to Figures (January, 2021)	ix
Table of Contents.....	xiii
List of Tables	xxi
Addresses And Phone Numbers	xxii
Chapter I General Customer Information	
1.01 Application for Electric Service - Deposits	I-1
1.02 Metering.....	I-1
1.03 Rate Determination	I-1
1.04 Billing	I-1
1.05 Apportionment of Costs for JEA System Extensions, Additions and Modifications	I-2
1.06 Right-of-Way and Access.....	I-3
1.07 Customer/Contractor Access to Locked JEA Facilities.....	I-3
1.08 Protection by Customer of JEA Property	I-3
1.09 Private Use of JEA Facilities Prohibited	I-4
1.10 JEA Does Not Work On Customer Facilities	I-5
1.11 Resale of Electricity.....	I-5
1.12 Sub-Serving by Customer Prohibited	I-5
1.13 Withholding or Discontinuing Service	I-5
1.14 Requirements for Disconnecting Electric Service	I-6
1.15 Removal of JEA Facilities from Customer's Property.....	I-6
1.16 Permit Processing Requirements for Public Agencies	I-7
1.17 Changes to Rules, Regulations, Rates, and Charges	I-7

JEA Rules & Regulations For Electric Service
Table of Contents

Chapter II General Service Information

2.01	Basic Requirements for Customer's Facility	II-1
2.02	Description of Customer's Installation	II-2
2.03	Alterations or Additions to Customer's Installation.....	II-2
2.04	Number of Services Provided.....	II-3
2.05	Master Metered Services	II-3
2.06	Service Location	II-3
2.07	Repair and Modification of Existing Services.....	II-4
2.08	Combination of 240V Delta and 120/240V Single-Phase Services	II-4
2.09	Rear Lot Line Services	II-5
2.10	Variances	II-5
2.11	Service Voltages Available.....	II-5
2.12	Voltage Control	II-7
2.13	Limitation of JEA Liability	II-7
2.14	Temporary Service.....	II-8
2.15	Area Lighting Services	II-8
2.16	Generators.....	II-8
2.17	Cogeneration Facilities	II-9
2.18	Standby Service	II-9
2.19	Alternate or Dedicated Services	II-9
2.20	Posting of Address.....	II-10
2.21	Customer Service Entrance Ground	II-10
2.22	Conductor Identification.....	II-10
2.23	Security of Service Entrance	II-10
2.24	Security of Service Equipment Ahead of JEA Point of Metering.....	II-11
2.25	Maximum Losses Ahead of JEA Point of Metering.....	II-11

Chapter III Secondary Metered Services - Overhead (0-600V)

3.01	General.....	III-1
3.02	Point Of Service.....	III-1
3.03	Service Drop Clearances.....	III-1
3.04	Mobile Home Pole/Service Pole OH Service.....	III-3
3.05	Underground Service from an Overhead Pole.....	III-3
3.06	Temporary Power Pole Service	III-3

JEA Rules & Regulations For Electric Service
Table of Contents

Chapter IV Secondary Metered Services - Underground (0-600V)

4.01	General.....	IV-1
4.02	Point of Service from an Underground Distribution System.....	IV-1
4.03	New Underground Developments	IV-1
4.04	Service Laterals in Underground Residential/Apartment Developments.....	IV-2
4.05	Commercial Services from Padmounted Transformers.....	IV-4
4.06	Special Requests for Padmounted Transformers.....	IV-5
4.07	Customer’s Responsibility to Protect Padmounted Equipment.....	IV-6
4.08	Underground Service from an Overhead Pole: Residential/Commercial.....	IV-6
4.09	Temporary Service.....	IV-7
4.10	Overhead to Underground Service Conversion.....	IV-8

Chapter V Downtown Underground Secondary Services

5.01	General.....	V-1
5.02	Point of Service.....	V-1
5.03	Network Service Area Load Restrictions	V-1
5.04	Load Balance	V-2
5.05	Customer Service Equipment	V-2
5.06	Network Service Connection Requirements.....	V-2
5.07	Spot-Network Customer Service Requirements.....	V-3
5.08	Customer’s Responsibility to Maintain Spot-Network Transformer Vault.....	V-4
5.09	Service from Padmounted Transformers	V-4
5.10	Underground Service from an Overhead Pole.....	V-5
5.11	New Underground Developments	V-5
5.12	Overhead Service.....	V-5
5.13	Temporary Service.....	V-6

Chapter VI Primary Metered Services

6.01	General.....	VI-1
6.02	Existing Primary Metered Customers.....	VI-1
6.03	Customer Service Equipment	VI-2
6.04	Point of Service.....	VI-2
6.05	Overhead Service.....	VI-2
6.06	Underground Service Padmounted Metering Transformers.....	VI-2
6.07	Underground Service Switchboard Mounted Metering Transformers	VI-3

JEA Rules & Regulations For Electric Service
Table of Contents

6.08	Underground Service Network Service Area	VI-4
Chapter VII Meters and Metering Equipment		
7.01	General.....	VII-1
7.02	Meter Tampering	VII-1
7.03	Types of Metering Systems	VII-1
7.04	Meter Socket Specifications	VII-2
7.05	Point of Metering.....	VII-3
7.06	Metering Equipment Cabinet Sealing/Locking Requirements	VII-4
7.07	Primary Service Instrument Transformer Installation	VII-4
7.08	Secondary Service Current Transformer Installation at Weatherhead	VII-4
7.09	Secondary Service Current Transformer Installation in Cabinets	VII-5
7.10	Raceways for Instrument Transformer Secondaries.....	VII-5
7.11	Raceway for Remote Interrogation Phone Line	VII-6
7.12	Location of Meters.....	VII-6
7.13	Identification of Meters	VII-7
7.14	Required Metering Installation Upgrades.....	VII-8
7.15	Meter Impulse Signals to Customer	VII-8
7.16	Meter Tests and Adjustments for Failed Meter	VII-8
7.17	JEA Approval of Customer Furnished Meter Center	VII-9
Chapter VIII Customer Utilization Equipment		
8.01	General.....	VIII-1
8.02	Voltage Fluctuation Limits	VIII-1
8.03	Motor Starting.....	VIII-2
8.04	Protection of Motors and Other Equipment.....	VIII-2
8.05	Equipment Voltage Rating	VIII-3
8.06	Arc Welders	VIII-3
8.07	DC Equipment (Other than Welders)	VIII-3
8.08	Flashing Lights	VIII-4
8.09	X-ray Machines, Broadcasting Equipment, and Arc Furnaces.....	VIII-4
8.10	Computers and Sensitive Electronic Equipment	VIII-4
8.11	Harmonics.....	VIII-4

JEA Rules & Regulations For Electric Service
Table of Contents

APPENDIX A – JEA Service Area Boundary Map

JEA Service Area North & West	A-2
JEA Service Area South & East	A-3

APPENDIX B - Figures

Figure

1.01 Padmounted Area - Clearance from Obstructions	B-1
1.02 Shrubbery Planting Specifications - Padmounted Transformers.....	B-2
2.01 JEA Service Load Calculation.....	B-3
3.01 Service Drop Clearances – Existing OH Service	B-4
3.02 Eyebolt Service Installations – Existing OH Service	B-5
3.03 Mast Service Installations – Existing OH Service	B-6
3.04 Mobile Home Pole/Service Pole – Existing OH Service.....	B-7
3.05 Temporary Pole - OH Service	B-8
4.01 Residential Service Lateral Installation - UG Service (URD & UG Service from OH Pole).....	B-9
4.01A Residential Meter Location – UG Service (URD & UG Service from OH Pole) Front Entry Garage with Side Entry Door & Sidewalk.....	B-10
4.01B Residential Meter Location – UG Service (URD & UG Service from OH Pole) Side Entry Garage with Side Entry Door	B-11
4.01C Overhead to Underground Conversion of Existing Residential Service with No Increase in Service Size.....	B-12
4.02 Residential Service Lateral Conduit Installation - UG Service (URD) Service Size: 400 Amp Maximum.....	B-13
4.03 Current Transformer Padmounted Installation 3 Phase UG Service	B-14
4.03A Transformer Pad Detail - UG Service 75 - 500 kVA, 3 Phase.....	B-15
4.03B Transformer Pad Detail - UG Service 750 – 3750 kVA, 3 Phase	B-16
4.03C Bollard Detail.....	B-17
4.03D Installation of Impulse Generation Equipment.....	B-18
4.03E Transformer Pad Detail – UG Service 1 Phase	B-19

JEA Rules & Regulations For Electric Service
Table of Contents

4.04	Residential Service Lateral Conduit Installation – UG Service from OH Pole.....	B-20
4.04A	Conduit/Service Box Installation – UG Service from OH Pole Commercial Service above 200 Amps & Multi-Metered Service.....	B-22
4.04B	Conduit/Conductor Installation – UG Service from OH Pole Commercial Service – 200 Amp Maximum.....	B-24
4.05	Temporary Pole – UG Service Service Size: 400 Amp Maximum.....	B-25
4.06	Temporary Service Pole – UG Service Service Size: 100 Amp Maximum.....	B-26
4.07	Meter Pedestal – UG Service 1 Phase & 3 Phase All Voltages Service Size: 400 Amp Maximum.....	B-27
5.01A	Downtown Service Area Boundary Map.....	B-29
5.01B	Downtown Service Area Boundary Map.....	B-30
6.01	Primary Metering Installation – Existing OH Service.....	B-31
6.02	Primary Metering Padmounted Installation – UG Service	B-32
7.01	Self-contained Meter Socket – Existing OH Service 1 Phase 3 Wire Service Size: 200 Amp Maximum 120/240V & 150 Amp Maximum 240/480V.....	B-33
7.01A	Self-contained Meter Socket – Existing OH Service 1 Phase 2 Wire Service Size: 100Amp Maximum 120V.....	B-34
7.02	Self-contained Meter Socket – UG Service 1 Phase 3 Wire 120/240V Service Size: 200 Amp Maximum.....	B-35
7.03	Self-contained Meter Socket – UG & Existing OH Service 1 Phase 3 Wire 120/240V Service Size: Above 200 Amps, 400 Amp Maximum	B-36
7.03A	Self-contained Meter Socket – UG & Existing OH Service 3 Phase 4 Wire All Voltages Service Size: Above 200 Amps, 400 Amp Maximum	B-37
7.04	Self-contained Meter Socket – Existing OH Service 1 Phase 3 Wire 120/208V Service Size: 200 Amp Maximum.....	B-38

JEA Rules & Regulations For Electric Service
Table of Contents

7.05	Self-contained Meter Socket –UG & Existing OH Service 3 Phase 4 Wire All Voltages Service Size: 200 Amp Maximum.....	B-39
7.05A	Self-contained (K Base) Meter Socket – UG & Existing OH Service 1 Phase and 3 Phase All Voltages Service Size: Above 400 Amps, 600 Amp Maximum	B-40
7.06	Current Transformer (Wall Mounted) – Existing OH Service 3 Phase All Voltages Service Size: Above 400 Amps, 800 Amp Maximum	B-41
7.06A	Current Transformer (Horizontal Mast Mounted) – Existing OH Service 3 Phase All Voltages Service Size: Above 400 Amps, 800 Amp Maximum	B-42
7.07	Current Transformer (Wall Mounted) – Existing OH Service 1 Phase 120/240V Service Size: Above 400 Amps, 800 Amp Maximum	B-43
7.08	Current Transformer (Cabinet Mounted) – UG Service 1 Phase and 3 Phase All Voltages Service Size: Above 400 Amps	B-44
7.09	Group Meter Socket Installation – UG & Existing OH Service Behind Building’s Service Equipment Main.....	B-45
7.10	Group Meter Socket Installation – UG & Existing OH Service 2 to 6 Meters	B-46
7.11	Group Meter Socket Installation – UG & Existing OH Service 2 to 6 Meters 1 Phase 120/240V Service Size: 200 Amp Maximum.....	B-47
7.12	Prewired Meter Center Installation – UG & Existing OH Service.....	B-48
7.12A	Jea smart meter communication conduit typ. all interior meter locations.....	B-49
7.13	Recessed Meter Socket/Enclosure Installation.....	B-50
8.01	Maximum Allowable Voltage Fluctuations.....	B-51
Glossary		Glossary-1

(This page left blank.)

LIST OF TABLES

CHAPTER II

- 2A Available Secondary Service Voltages..... II-6
2B Available Primary Service Voltages..... II-7

CHAPTER III

- 3A Service Drop Requirements..... III-2

CHAPTER IV

- 4A Conduit and Service Box Requirements for Underground
Commercial Services from an Overhead Pole.....IV-9

CHAPTER VI

- 6A Service Equipment Requirements for Primary Service VI-2

CHAPTER VIII

- 8A Voltage Fluctuation Limits VIII-1
8B Across the Line Motor Starting Limits VIII-2

(This page left blank.)

ADDRESSES AND PHONE NUMBERS
JEA DEPARTMENT/SECTION

Business Support Center.....	(904) 665-6250
21 Church Street W., T7 Jacksonville, FL 32202	
Customer Experience Center	
Business Office.....	(904) 665-6000
21 W. Church Street, CC1 Jacksonville, FL 32202	
Business Office Toll Free Line.....	1-800-683-5542
Electric Services	
Reference Appendix A	
Forestry.....	(904) 665-6050
2325 Emerson Street Jacksonville, FL 32207	
Customer Field and Meter Services	
Electric Meter Services (commercial meters).....	(904) 665-6780
6674 Commonwealth Av Jacksonville, FL 32254	
Field Services (residential).....	(904) 665-6970
6674 Commonwealth Av.....	FAX (904) 665-6988
Jacksonville, FL 32254	
Revenue Assurance Services (Investigation).....	(904) 665-6000
21 W. Church Street, CC1 Jacksonville, FL 32202	
Electric System Planning.....	(904) 665-7108
21 W. Church Street, T10 Jacksonville, FL 32202	
Underground Cable Locate.....	1-800-432-4770
Underground Conduit Location:	
North/West Area (Westside Service Center).....	(904) 665-6900
South/East Area (Southside Service Center).....	(904) 665-6778
Underground Residential Development Service Location.....	recordsrequests@jea.com

JEA Rules & Regulations For Electric Service
Addresses and Phone Numbers

CITY/COUNTY ELECTRICAL INSPECTION AUTHORITY

City of Atlantic Beach	(904) 247-5826
Building & Zoning 800 Seminole Rd. Atlantic Beach, FL 32233	
Clay County	(904) 269-6307
Building Department P.O. Box 1367 Green Cove Springs, FL 32043	
City of Jacksonville	(904) 255-8500
Building Inspection, Electrical Inspections 214 N. Hogan St. Jacksonville, FL 32202	
Town of Orange Park.....	(904) 264-2635
Economic and Community Development 2042 Park Av. Orange Park, FL 32073	
St. Johns County Building Department	(904) 827-6800
4020 Lewis Speedway P. O. Box 349 St. Augustine, FL 32085	

Chapter I General Customer Information

(This page left blank.)

1.01 APPLICATION FOR ELECTRIC SERVICE - DEPOSITS

Anyone desiring electric service from JEA must make an "Application for Electric Service". Contact JEA Customer Experience Center online at www.jea.com, by phone (904) 665-6000 or in person at JEA's Downtown Customer Care Center. The application may be made in person or by a duly authorized agent. Information required includes personal identification, name to whom bills are to be rendered, street name and house number, zip code; and if in rural territory, other information to assist in locating the customer's premises. In addition, a monetary deposit or other contractual arrangement to pay a deposit may be required. The deposit amount shall be set by JEA and will vary according to the type of service provided. A connection charge will be assessed and will appear on the first bill. JEA will not connect the electric service until the necessary application has been made and any deposit is paid or other contractual arrangement has been accepted. This should be done as far in advance of the time electrical service is desired as possible. JEA requests that the electrical permit information be received from the appropriate City/County Electrical Inspection Authority prior to the customer's application for service. When the customer complies with the JEA Rules and Regulations and any applicable codes and inspections, the application for service will be finalized by JEA. Upon acceptance thereof by JEA, the application constitutes a service contract based upon these and other JEA rules, regulations, rates and policies and becomes effective at the time the customer is connected to JEA's system.

1.02 METERING

JEA will furnish free of charge the necessary watt-hour meter(s) for the electrical service provided. All electrical energy furnished by JEA shall be determined by this meter's measurements. In any case where the meter(s) fails to record accurately due to a defect not caused by the customer, adjustments will be made in accordance with Chapter VII, Meters and Metering Equipment. JEA provides flat rate temporary services for new residential construction in Duval County. The flat rate is collected in conjunction with the building permit.

1.03 RATE DETERMINATION

JEA personnel determine the rate schedule, which is to apply to any individual customer service account in accordance with the rates filed with the Florida Public Service Commission. Rate schedules and information regarding their application may be obtained from JEA Customer Experience Center.

1.04 BILLING

Meter readings will be taken monthly and bills rendered as soon thereafter as practical. Bills are due when rendered and shall be paid to JEA . Bills that become past due shall subject the service to disconnection. Late fee on past due bills, discontinuance of service and reconnection

charge shall be in accordance with the latest edition of the applicable JEA Policy and Procedures.

JEA will total two or more meters into one bill when JEA cannot provide the size of service requested at any one point of service without the installation of two or more padmounted transformers. The required metering equipment should be installed in close proximity to each other or the customer will be responsible for any additional metering expense. In some cases, the meter location might exclude the customer from consideration for "totalized" billing. This will usually affect the amount of the electric bill. Further information may be obtained from JEA Business Support Center. JEA will also total two or more meters for customers served under the Multiple Account Load Factor Improvement Rider (MA). Reference Tariffs for additional information.

JEA also offers a Consolidated Billing Service whereby the electric bills from more than one point of service (different addresses) can be combined into one billing. This will not affect the total amount of the bill but can simplify auditing and other aspects of electric billing for those customers who currently receive multiple electric bills. Further information may be obtained from JEA Customer Experience Center.

Free service shall not be furnished by JEA to any person or to the City, State, Federal Government, or a public agency or instrumentality. Every user of the JEA's electric system shall be subject to equal and uniform rates and charges fixed by JEA, for class of user within which the user falls, without reduction or other discrimination.

1.05 APPORTIONMENT OF COSTS FOR JEA SYSTEM EXTENSIONS, ADDITIONS AND MODIFICATIONS

Upon receipt of permit information, written notice, or application for service as provided in Section 1.01, Application For Electric Service - Deposits, JEA will proceed to do such work and provide and install such equipment as may be necessary in order to render service. This may include the extension of or additions to the existing JEA system.

In the case where an extension, addition and/or modification for an existing customer is made necessary by customer action or request and where no increase in load requirements is involved, the customer is responsible for all associated costs. In the case of temporary services (i.e.; less than two years), the customer shall be required to provide a contribution-in-aid-of-construction charge for the installation and removal of any facilities necessary to provide the temporary service. The minimum contribution-in-aid-of-construction charge for providing a temporary service will be **\$75.00**. In the case of temporary services in Duval County where the flat rate applies, the contribution-in-aid-of-construction is included in the flat rate.

In the case of an extension, addition and/or modification associated with a new customer or with additional load requirements for an existing customer, JEA shall provide the necessary system extension, addition and/or modification and determine the required contribution-in-aid-

of-construction by applying the appropriate Standard Service Revenue Allowance (SSRA) and Non-Standard Service Revenue Allowance (NSSRA).

Generally, the following are excluded from the cost determination:

- The material cost of the transformer, service drop and meter.
- The portion of an extension built on public right-of-way and capable of serving other customers, either existing or future.

The following are examples of situations where JEA may require that customer provide contribution-in-aid-of-construction:

- A customer requesting a small three-phase service in areas where only single-phase distribution exists, especially residential areas.
- Lengthy extensions on private property.
- Extensions along public right-of-way to serve low usage loads, such as lighted sign boards and pumps where connection of additional customers is unlikely.
- A customer requesting JEA to provide an additional service voltage and/or point of service. Reference Section 2.04, Number of Services Provided.

1.06 RIGHT-OF-WAY AND ACCESS

Duly authorized agents of JEA shall at all times have access to JEA facilities on the customer's premises for the purpose of installing, maintaining, inspecting and removing JEA property; and shall have access to the premises during normal working hours for the purpose of meter reading. Failure to provide such access may be grounds for discontinuance of service and relocation of metering equipment to an accessible location at the customer's expense. JEA shall not be liable for trespass during the performance of these activities. The customer shall grant or cause to be granted to JEA, without cost to JEA, all rights, easements, permits and privileges which in the opinion of JEA are necessary for the rendering of service to the customer.

1.07 CUSTOMER/CONTRACTOR ACCESS TO LOCKED JEA FACILITIES

When access to locked JEA facilities, (i.e.; padmounted transformers, gates, etc.) is required to perform "Permitted" work, the customer/contractor shall make arrangements with JEA Customer Experience Center for entry (24 hours notice required). Only qualified personnel may have access to locked facilities. The customer/contractor shall not leave JEA facilities unattended. It is the customer's/contractor's responsibility to secure all unlocked JEA facilities when leaving or upon completion of work.

1.08 PROTECTION BY CUSTOMER OF JEA PROPERTY

The customer is responsible for properly protecting JEA's property on the customer's premises, and shall permit no one but persons authorized by law to have access to JEA wiring, meters and apparatus. In the event of any loss or damage to JEA's property caused by or arising out of carelessness, neglect or misuse by the customer, the cost of replacing or repairing such damage

shall be paid by the customer. The customer also responsible for AURORA protection and any damages caused to JEA facilities by the lack of AURORA mitigation.

The customer shall not allow:

- Construction or placement of anything that will restrict JEA's access to overhead or underground facilities (i.e.; poles, downguys, padmounted switches/transformers, etc.). Reference Figure 1.01, Padmounted Area – Clearance from Obstructions.
- Trees, vines, shrubs, or fences to interfere with JEA's visual reading of or physical maintenance to meters.
- Trees, vines or shrubs to interfere with JEA overhead service drop or underground service lateral.
- The planting of ornamental shrubs or other growth which may hinder ventilation for and maintenance of any padmounted facilities. Reference Figure 1.02, Shrubbery Planting Specifications - Padmounted Transformers.
- The installation of any equipment, (i.e.; air conditioners and compressors, water softeners, etc.) within five feet in any direction of any padmounted facilities. The exhaust for heat generating equipment must be directed away from the JEA transformer if located within five feet in any direction of the transformer. Reference Section 7.12, Location of Meters for clearances from metering equipment.
- Storage or installation of items not necessary for providing electric service in vault-type enclosures (spot-networks). Such interference may become hazardous to persons and may cause the customer's service to be interrupted, or service to other customers to be adversely affected.
- JEA owned and maintained primary and secondary conduits to be installed under buildings or other similar structures. (This is not applicable to driveways and sidewalks.) For conduit maintenance responsibilities, reference Chapters IV, Secondary Metered Services – Underground (0 – 600V); V, Downtown Underground Secondary Services and VI, Primary Metered Services.

CAUTION: The customer should not attempt to remove or trim trees which are in close proximity to overhead power lines. Contact JEA T&D Preventive Maintenance.

1.09 PRIVATE USE OF JEA FACILITIES PROHIBITED

Except as may be allowed by contract with other entities, or by written permission for one-time temporary public or quasi-public functions, no person or entity shall use JEA poles, wires, towers, structures or other facilities for the purpose of fastening or supporting any radio or television aerials or other equipment, or any wires, ropes, signs, banners or other facilities, nor locate same in proximity to JEA property or facilities. JEA shall have the right to order such items removed, or to remove same and charge the violator without any liability.

1.10 JEA DOES NOT WORK ON CUSTOMER FACILITIES

Except as may be specifically mentioned in these Rules and Regulations or in related JEA Policies and Procedures, JEA does not install or repair wiring or equipment on customer's premises. JEA cannot be responsible for the electric system beyond the point of service and does not assume any responsibility for, or liability arising because of, the condition of wires or apparatus on the premises of any customer beyond this point.

1.11 RESALE OF ELECTRICITY

The resale of electricity may be allowed only by customers served under Rate Schedule MS (Municipal Service), as the Rate Schedule does or may provide, and by utilities that purchase wholesale power.

A master metered customer may be allowed to submeter electrical consumption of tenants for the purpose of allocating costs billed to the master meter by JEA. The costs allocated to the tenants shall be only the costs billed by JEA and shall not include the costs of the submeters, distribution losses, administration costs, etc., which must be recovered through the rent. The master metered customer shall submit the method of cost allocation and any subsequent changes to JEA Financial Planning and Rates prior to submitting any bills to a tenant.

The resale of electricity by a customer under any other circumstance is prohibited.

1.12 SUB-SERVING BY CUSTOMER PROHIBITED

The customer may not build or extend his lines across or under a street, alley, lane, court, avenue or other way in order to furnish service for adjacent property through one meter even though such adjacent property is owned by the customer, unless written consent is obtained from JEA. Consent may be given only when such adjacent properties are operated as one integral unit, under the same name, for carrying on parts of the same business. When and if such consent is given, the customer must obtain any necessary state and municipal permits; and all construction shall be in accordance with applicable codes, installed by duly licensed professionals, and subjected to applicable inspection procedures.

1.13 WITHHOLDING OR DISCONTINUING SERVICE

JEA reserves the right to discontinue service without notice for any of the following reasons:

- Repairs.
- Want of supplies.
- Force Majeure including but not limited to – riots; strikes; lockouts; insurrections; acts of federal, state, municipal or other authorities; acts of God; acts of war; terrorism; acts of the public enemy; and all other acts beyond the control of JEA.
- Fraudulent representation in relation to the consumption of current amount or the securing of same.
- Suspected illegal or unsafe wiring.

JEA Rules & Regulations For Electric Service
Chapter I General Customer Information

- Using electricity without making proper application.
- Unauthorized use of electricity.
- Violation of Section 812.14, Florida State Statute (trespass and larceny with relation to utilities).

JEA reserves the right to discontinue service upon reasonable notice for any of the following reasons:

- Non-payment of bills for services when due.
- Issuing two or more dishonored payments within a nine- (9) month period.
- Non-conformance with state or local codes or ordinances.
- Violation of any of the JEA Rules and Regulations for Electric Service.
- JEA may withhold a new service or discontinue existing service unless all past due indebtedness to JEA at any one or more other service locations of the customer has been settled in full; provided however, that said past due indebtedness may at the option of JEA, be transferred to any active account of the customer and upon so being transferred becomes a part thereof.

1.14 REQUIREMENTS FOR DISCONNECTING ELECTRIC SERVICE

The customer must request through JEA Customer Experience Center to have power to a service disconnected and/or removed. Only JEA personnel will perform the disconnection and/or removal of the service conductors and removal of all meters and/or metering equipment. Customers are not allowed to remove any of their service main facilities (i.e.; temporary power poles, service main breakers, etc.) until all JEA work is complete.

1.15 REMOVAL OF JEA FACILITIES FROM CUSTOMER'S PROPERTY

JEA reserves the right to remove any JEA owned equipment (i.e.; padmounted or polemounted transformers, primary cable, metering equipment, etc.) that has not been utilized for more than one year. This removal may be made with no further notification to the customer.

JEA will not be liable for any equipment (i.e.; transformer pad, secondary conductors, etc.) belonging to the customer as a result of this removal.

1.16 PERMIT PROCESSING REQUIREMENTS FOR PUBLIC AGENCIES

Certain City, County, State and Federal Agencies (hereafter termed AGENCY) are allowed by law to perform and inspect electrical work done on their facilities. JEA recommends that when this work is performed the AGENCY follow the normal "Permit Procedures" through the local "Electrical Inspection" office. At the AGENCY's option they may request that JEA create an "in-house" permit and forego the normal permitting process. This will require a "Letter of Request" describing the address, nature of work, electrical information and other necessary information detailing the work to be performed for each service. The letter will require the

JEA Rules & Regulations For Electric Service
Chapter I General Customer Information

signature of the appropriate level manager (i.e.; Director of Maintenance, Administrator of Services, etc.) that is on record with JEA as having authority to request such work. Reference Section 2.02, Description of Customer's Installation and Figure 2.01, JEA Service Load Calculation.

Upon completion of all work by the AGENCY, JEA will require a letter for each service stating that the installation, repair, modification, etc. meets or exceeds all applicable codes, ordinances or laws. This letter will require the signature and license number of a “Professional Engineer”, “Architect”, or “Master Electrician”. Upon receipt of this letter and an approved “Application for Electric Service” JEA will release all necessary line work and meter work to energize the service. Reference Section 1.01, Application for Electric Service - Deposits.

Please forward all correspondence to JEA Service Engineer, Electric Services.

1.17 CHANGES TO RULES, REGULATIONS, RATES AND CHARGES

JEA reserves the right to change or amend its rules, regulations, rates, or other charges, at any time for any reason and such changes or amendments, shall become effective upon the date determined by the Authority.

(This page left blank.)

Chapter II General Service Information

(This page left blank.)

2.01 BASIC REQUIREMENTS FOR CUSTOMER'S FACILITY

All wiring and electrical equipment of the customer shall be installed in accordance with these Rules and Regulations and in accordance with the latest edition of the National Electrical Code and the National Electrical Safety Code, as well as with guidelines of local inspection authorities. All wiring installations must be inspected and approved by an authorized electrical inspector as required by law. Each service connected by JEA shall include a neutral with the exception of dedicated fire pump services connected at a metered transformer bus. **JEA requires 10 business days from an approved “Temporary Final” or “Final” inspection to allow for the installation of new JEA facilities.**

JEA may refuse service to any new or altered installation, or disconnect service to any existing installation, which in the opinion of JEA, constitutes a hazard to the public, to other customers, or to its employees. The customer is cautioned against the purchase and use of electrical equipment that is not approved by competent authority.

All new permanent services (secondary and primary voltages) shall be installed underground. This is applicable to both planned underground developments and designated overhead areas. In overhead areas, the service shall be installed underground from a JEA pole designated by JEA Electric Services.

The maximum service sizes for underground services from pole will apply; reference Table 2A, Available Secondary Service Voltages. Also reference Figures 4.04, Residential Service Lateral Conduit Installation – UG Service from OH Pole; 4.04A, Conduit/Service Box Installation (Commercial Service & Multi-Metered Service) – UG Service from an OH Pole; 4.04B, Conduit/Conductor Installation (Commercial Service 100 Amp Maximum) – UG Service from OH Pole; 4.01, Residential Service Lateral Installation UG Service (URD & UG Service from OH Pole) and 4.02, Residential Service Lateral Conduit Installation – UG Service Residential Development (URD) Service Size: 400 Amp Maximum.

Exception: A new permanent service may be served OH if **any** of the following apply:

- The new service is located in a multi-occupancy building with an existing OH service.
- The addition of the new service does not require a service increase for the existing service that would exceed the limitations for an OH service. Reference Table 2A, Available Secondary Service Voltages.
- The new service will be temporary for a period not to exceed two years at which time the service will need to be fed from the new permanent structure. Reference Sections 2.10, Variances.
- The new service is to feed an Environmental Protection (EP01) service.

JEA shall install required facilities on the same side of the right-of-way (R/W) as the customer's service. The customer/contractor shall not install services across the R/W.

2.02 DESCRIPTION OF CUSTOMER'S INSTALLATION

The customer shall furnish JEA Electric Services with a description of the customer's new installation. This information is necessary to enable JEA to determine the types and methods of service for which the customer's installation may qualify. The customer should not proceed with any stages of design or construction until service voltage, service location and other service requirements have been established by JEA Electric Services. Any required JEA distribution system extension may require a good deal of time. It is recommended that the Customer, Builder, Electrician, or a Representative contact JEA Electric Services during the initial planning phase to assure the timely installation of the distribution electrical system to assure that service will be available when required.

At a minimum, the following items shall be furnished for each commercial, industrial and multi-family residential installation:

- Site Plan: Showing building(s), paved areas, sidewalks, location of main disconnect(s), desired electrical service location(s) and desired meter location(s).
- Power Distribution Diagram (one for each service).
- Service Load Calculation (one for each service). See Figure 2.01

A load calculation is required for all three-phase services and all single-phase services 300 Amps or greater. JEA reserves the right to request the size and harmonic content of any anticipated non-linear load as part of the load calculation, particularly in cases where the service is for a commercial office building.

For 120/240V, single-phase residential services up to 200 Amps, the information contained on the electrical permit will generally be sufficient to enable JEA to determine service requirements. The customer shall contact JEA Electric Services to determine the service location. Reference Section 2.06, Service Location.

2.03 ALTERATIONS OR ADDITIONS TO CUSTOMER'S INSTALLATION

The capacity of JEA's electrical service to the customer is based on information furnished by the customer at the time of initial service design. Therefore, no significant additions or changes shall be made to the customer's installation without first notifying the proper inspection authority and providing the information described in Section 2.02, Description of Customer's Installation to JEA Electric Services.

Failure to provide this information may adversely affect the quality of service to the customer and to other customers served from the same JEA facilities. Extreme cases may require disconnection of customer service while corrective action is taken.

2.04 NUMBER OF SERVICES PROVIDED

- Normally, JEA shall provide only one point of service to a building or structure. If requested by the customer, JEA may elect to provide additional points of service

JEA Rules & Regulations For Electric Service
Chapter II General Service Information

where economically and functionally feasible and where approved by the local inspection authority when the criteria of the current National Electric Code (NEC) is met.

If the customer requires multiple voltages to their building, the customer shall be responsible for their own voltage transformation. JEA shall not install two voltages to a building solely for the convenience of the customer. The customer shall provide and maintain a separate distribution system for each JEA service provided. Interconnection of multiple JEA services through the customer's distribution system shall not be allowed. In some cases, contribution-in-aid-of-construction may be required. Reference Section 1.05, Apportionment of Costs for JEA System Extensions, Additions and Modifications.

For multiple services, a permanent plaque or directory shall be installed at each service disconnect location denoting all other services supplying that building or structure. The plaques shall:

- Have a red background with white lettering.
- Be permanently mounted on the outside of the main disconnects.
- Designate the number of services located on the building.
- Designate where services are located on the building.
- Specify if services are served from the same or different transformers.

2.05 MASTER METERED SERVICES

Master Metering of new residential, multi-occupancy buildings shall be prohibited except when the costs of purchasing and installing separate meters are not justified by the long-run benefits to the electrical consumers in such buildings with respect to the portion of electric energy used. The owner of any new residential multi-unit building requesting an exception shall be required to provide JEA an evaluation demonstrating the long-run benefits of master metering over individual metering for that building. Reference Section 1.11, Resale of Electricity

Master Metering of commercial and industrial buildings shall be allowed.

2.06 SERVICE LOCATION

JEA Electric Services designates/approves the service location for each electrical service provided and each existing electrical service where the service entrance is being modified. The customer shall contact JEA Electric Services for a written service location (minimum 48 hours notice required) prior to installation of the customer's wiring. **JEA shall not be bound by service locations claimed to have been given orally.**

In cases where the customer desires a service location other than the one designated by JEA, the desired alternate service location may be granted by JEA provided the following conditions are met:

- The alternate service location is approved prior to the installation of new service or the modification of existing service.
- The customer provides a contribution-in-aid-of-construction for any additional

JEA Rules & Regulations For Electric Service
Chapter II General Service Information

expenses required for JEA to provide and maintain service from the alternate service location.

- The alternate service location does not conflict with existing or future construction of JEA facilities.
- The alternate service location meets all codes, local ordinances and the provisions of any applicable JEA rules, regulations, policies or directives.

For underground services (URD and underground service from OH pole), the meter shall be located within 10 feet of the corner closest to the JEA/developer installed service conduit or pole and on the same side of the structure as the JEA/developer installed service conduit for that particular lot. Additionally, for zero lot line structures, the meter shall not be located on the zero lot line side.

2.07 REPAIR AND MODIFICATION OF EXISTING SERVICES

When an existing service is repaired or modified and that repair or modification includes the replacement of the service entrance on the line side of the JEA point of metering, the electrical service shall be brought into accordance with the requirements of these Rules and Regulations. In any case, OH services shall comply with the minimum clearances listed in Table 3A, Service Drop Requirements. JEA also requires the installation of an eyebolt for overhead residential services that require replacement of the service drop or reconnection at the point of service. Underground residential services requiring the replacement of a direct buried service shall require a customer installed conduit in accordance with Section 4.04, Service Laterals in Underground Residential/Apartment Developments. For metering specifications, reference Section 7.14, Required Metering Installation Upgrades.

Electrical contractors shall remain on site until JEA reconnects services that are repaired after normal business hours that have not been approved by the local Electrical Inspection Agency. Normal business hours are defined as: Monday through Friday, 7AM – 3:30PM.

2.08 COMBINATION OF 240V DELTA AND 120/240V SINGLE-PHASE SERVICES

A customer, (residential or commercial) with a 240V 3-phase 3-wire delta metered service and a 120/240V single-phase 3-wire metered service shall be required to combine both services into a single 120/240V single-phase 3-wire or 120/240V 3-phase 4-wire service if there is an increase in service size for either service.

2.09 REAR LOT LINE SERVICES

In some areas JEA maintains a distribution system along rear lot lines as opposed to the normal location, within the road right-of-way. JEA shall require the customer to relocate the point of attachment to accept service from the road when a customer with rear lot line service increases service size. Contact JEA Electric Services. Reference Sections 2.10, Variiances and 2.01, Basic Requirements for Customer's Facility.

2.10 VARIANCES

A customer may request that a variance to these Rules and Regulations be granted. Contact JEA Electric Services for a written variance **prior** to the installation of the customer's wiring. **JEA will not be bound by variances claimed to have been given orally.**

Variations that will be considered include:

- Vertical clearance requirements for a residential service drop.
- Vertical clearance requirements for a commercial service drop.
- Continuation of rear lot line service.
- Services that will be temporary until new permanent structure is completed.

2.11 SERVICE VOLTAGES AVAILABLE

It is essential that the customer consult JEA Electric Services before proceeding with the purchase of equipment or the installation of wiring. The type of service and service voltage provided will be determined by JEA Electric Services based on the character of the customer's load and the type of JEA distribution system in the area. If requested by the customer, JEA may provide an alternate service voltage; contribution-in-aid-of-construction may be required. Reference Section 1.05, Apportionment of Costs for JEA System Extensions, Additions and Modifications. The following tables will be used as a guide in determining the type of service(s) for which the customer may qualify.

JEA Rules & Regulations For Electric Service
Chapter II General Service Information

TABLE 2A
AVAILABLE SECONDARY SERVICE VOLTAGES

SERVICE VOLTAGE & DESCRIPTION	MINIMUM DEMAND	MAXIMUM SERVICE SIZE	NOTES
120V 1ph 2 wire Underground from pole 1ph padmounted transformer	N/A N/A	100 Amps 100 Amps	2
120/240V 1ph 3 wire Overhead (Not available for new permanent services) Underground from pole 1ph padmounted transformer	N/A N/A N/A	600 Amps 800 Amps 800 Amps	1 2 3
120/240V 3ph 4 wire Delta Overhead (Not available for new permanent services) Underground from pole Special padmounted transformer	5 HP, 3ph 5 HP, 3ph 5 HP, 3ph	400 Amps 600 Amps 400 Amps	4,5 2,4,5 5, 6
120/208V 1ph 3 wire Overhead (Not available for new permanent services) 3ph padmounted transformer Network	N/A N/A N/A	200 Amps 200 Amps 200 Amps	7 7 8
120/208V 3ph 4 wire Wye Overhead (Not available for new permanent services) Underground from pole 3ph padmounted transformer Network	75 kVA 75 kVA 150 kVA N/A	600 Amps 1200 Amps 4,000 Amps 3,000 Amps	1 2 9 10
240/480V 1ph 3 wire Overhead Underground from pole	N/A N/A	150 Amps 150 Amps	11 2, 11
480V 1 ph 2 wire Overhead (Not available for new permanent services) Underground from pole	N/A N/A	150 Amps 150 Amps	12 2, 12
277/480V 3ph 4 wire Wye Overhead (Not available for new permanent services) Underground from pole 3ph padmounted transformer Spot-Network	150 kVA 150 kVA 150 kVA 1,000 kVA	600 Amps 600 Amps 6,000 Amps 8,000 Amps	1, 9 2, 9 9 10
<p>NOTES</p> <ol style="list-style-type: none"> If a JEA service pole is within 50 feet of a customer's point of attachment, the maximum overhead service size may be 800 amps. Location of service pole to be determined by JEA Electric Services. Reference Section 4.08, <u>Underground Service from an Overhead Pole: Residential/Commercial</u>. MAXIMUM SERVICE SIZE for condominium and apartment buildings is 1,600 Amps. JEA will provide only open delta service. 3 ph 4 wire Wye required for services larger than 600 Amps or with motors larger than 20 HP. In the case of 3-phase services using dedicated transformer banks located off the right-of-way, 120/240V closed Delta will not be provided. Available for Underground Development sewer lift stations or customers relocating 3ph equipment which operates on 120/240V. Bank must be open delta. Maximum motor size for any one motor is 25 HP. Customer may be required to provide a contribution-in-aid-of-construction, reference Section 1.05, <u>Apportionment of Costs for JEA System Extensions, Additions and Modifications</u>. Available only in multi-occupancy buildings served by a three-phase 120/208V padmounted transformer, or where a three-phase 120/208V pole mounted transformer bank exists. Available only within the Network Service Area, reference Figures 5.01A & 5.01B, <u>Downtown Service Area Boundary Map</u>. MINIMUM DEMAND is reduced to 75 kVA with at least 35 kVA of three-phase equipment connected. Reference Section 5.03, <u>Network Service Area Load Restrictions</u>. Available only for street lighting circuits or where no other voltage is required for that particular service/building/structure. Available only for DOT roadway lighting. <p>Service Voltage to be determined by the JEA Service Engineer.</p>			

JEA Rules & Regulations For Electric Service
Chapter II General Service Information

TABLE 2 B
AVAILABLE PRIMARY SERVICE VOLTAGES

SERVICE VOLTAGE & DESCRIPTION*	MINIMUM DEMAND	MAXIMUM DEMAND	NOTES
2,400/4,160V 3ph 4 wire Wye	Not Available	Not Available	1
7,620/13,200V 3ph 4 wire Wye	3000 kVA	-----	2
15,200/26,400V 3ph 4 wire Wye	3000 kVA	-----	2
NOTES: 1. Existing 4 kV customers desiring to add load such that total demand is 750 kVA or greater will, in most cases, be required to change service to another voltage. The service change may be either to a higher primary voltage as designated by JEA or to a secondary service voltage. 2. When reasonable upper load limits are exceeded; a higher voltage, including transmission level voltages of 69 kV and above, may be required. 3. All new primary metered services shall be installed underground. Reference Section 2.01, <u>Basic Requirements for Customer's Facility</u> . 4. All existing primary metered services modified to a higher primary voltage or changed to a secondary voltage shall be installed underground. Reference Section 2.01, <u>Basic Requirements for Customer's Facility</u> . Service Voltage to be determined by the JEA Service Engineer.			

2.12 VOLTAGE CONTROL

To the extent possible, JEA will deliver steady state continuous voltage in accordance with the following guidelines:

- For service rendered to residential and/or commercial customers whose principal consumption shall be for lighting and non-industrial loads, the voltage at the point of service shall not exceed 5% above or below the service voltage.
- For service rendered to customers whose principal consumption shall be for industrial and/or inductive loads the voltage at the point of service shall not exceed 7.5% above or below the service voltage.

Upon request, JEA will test the voltage supplied to the customer at the point of service and take corrective action if it is found to be consistently outside the specified ranges. These limits for voltage regulation apply to steady state continuous service voltages only. They are not applicable for transient voltage spikes, surges, impulses, voltage sags, momentary interruptions and any other instantaneous voltage fluctuations that are due to faults and disturbances in the JEA Electrical Distribution System or that of the customer. It is the customer's responsibility to install any power conditioning equipment that may be required to provide closer voltage regulation than specified above, or continuous non-interruptible power where required by the nature of the customer's sensitive electronic load.

2.13 LIMITATION OF JEA LIABILITY

JEA will use reasonable diligence at all times to provide dependable service at the nominal voltage, but does not guarantee, nor will it be liable to the customer, for complete or partial failure or interruption of service, for fluctuations in voltage, or for phase failure or reversal and the direct or indirect impact of these service conditions to the customer. It is the customer's responsibility to install the required grounding, phase protection, surge suppression and power

JEA Rules & Regulations For Electric Service
Chapter II General Service Information

conditioning equipment necessary to protect the customer's property from damage under these conditions.

Unless JEA has been negligent in the connection of a customer's service or in the installation and/or maintenance of JEA facilities, JEA shall not be liable for any occurrence, act or omission caused directly or indirectly by mechanical failure of equipment and/or facilities; by repairs or adjustments to its system; for want of supplies; by riots; strikes; civil unrest; insurrections; accident; litigation; interference by Federal, State or Municipal Governments; acts of God; acts of the public enemy; or any other cause beyond JEA control.

After the electric energy passes the point of service, it becomes the property of the customer and JEA shall not be liable for loss or damage to any person or property whatsoever resulting directly or indirectly from the use or misuse or presence of said electric energy on the customer's premises.

NOTE: Locating electric lines that are owned and maintained by the customer is the responsibility of the customer. JEA is not responsible for locating facilities beyond the point of service.

2.14 TEMPORARY SERVICE

Temporary service shall comply with all requirements applicable to permanent services (i.e.; application for electric service, code compliance, inspection by local authorities, etc.). In addition, the customer shall be required to provide a non-refundable contribution-in-aid-of-construction for the installation and removal of any facilities necessary to provide the temporary service. Reference Section 1.05, Apportionment of Costs for JEA System Extensions, Additions and Modifications. This charge does not include JEA's normal deposit for application for electric service, the service connection for the particular type of service rendered, or the cost of any portion of the temporary service in conjunction with providing permanent service.

The customer may not energize the permanent electrical service to a facility under construction using the temporary construction power except for test purposes. This is to avoid the possibility of interconnecting the permanent and temporary sources when permanent power is connected.

2.15 AREA LIGHTING SERVICES

JEA provides area lighting services within the JEA service territory. Please contact the appropriate Service Engineer referenced in Appendix B for specific details as to the type of lighting JEA provides and associated installation requirements.

2.16 GENERATORS

All portable, emergency or standby generation units that can potentially be connected temporarily or permanently to the customer's internal distribution system must be approved by JEA System Analysis. Customers shall provide and maintain a JEA approved device as an isolation point on the customer's portable, emergency or standby generator system in accordance with the latest edition of the JEA Safety and Technical Procedure, "Operations & Interconnection of Open and Closed Transition Standby Generators". Failure to provide this

JEA Rules & Regulations For Electric Service
Chapter II General Service Information

isolation point constitutes a possible safety hazard and may be grounds for disconnection of electrical service. Reference Section 2.17 Cogeneration and Distributed Generation Facilities for all installations that allow generation to be connected with the JEA system longer than 30 seconds.

Complete the Generator Application online.

https://www.jea.com/engineering_and_construction/electric_development/standby_generator_request/

If for any reason the customer's generator installation is not in compliance with this section, JEA will reschedule the work for a time when the customer will turn the generator off, disable the start circuit and allow JEA to put a lock on the generator control box to prevent starting the generator.

2.17 COGENERATION AND DISTRIBUTED GENERATION FACILITIES

Customer requests to be interconnected into the JEA system as a Public Utility Regulatory Policy Act (PURPA) approved cogenerator or distributed generator shall be made through JEA Electric Production Resource Planning. The customer's facility shall comply with the latest edition of the JEA Safety and Technical Procedure, "Parallel Operations and Interconnection of DG Facilities on the Distribution System". The customer shall be responsible to protect JEA equipment (transformers, metering equipment, conductor, etc.) from an AURORA attack occurring within the customer's facility.

2.18 STANDBY SERVICE

JEA shall not provide standby service to customers with internal generation except as allowed by contract with cogeneration facilities.

2.19 ALTERNATE OR DEDICATED SERVICES

Upon customer request, JEA may provide either an alternate service or a dedicated distribution feeder as allowed by JEA policies and procedures. Contact JEA Electric Services for information.

2.20 POSTING OF ADDRESS

The customer is required to post the address before electrical service will be connected. The customer shall permanently maintain the numbers. Each facility that will be served by JEA shall have the facility's assigned street address numbers posted in order to clearly identify the metering equipment.

2.21 CUSTOMER SERVICE ENTRANCE GROUND

JEA provides a grounded neutral with all services rendered. The customer shall provide and maintain a grounding electrode system as described in the latest edition of the National Electrical Code (NEC) and local inspection authority requirements.

A low resistance ground is important in providing protection of the customer's facility. JEA

JEA Rules & Regulations For Electric Service
Chapter II General Service Information

strongly recommends that the customer install a grounding electrode system with a maximum resistance to ground of 25 ohms. Lower resistance to ground may be necessary to operate and protect some computers and solid state equipment.

JEA shall not be held responsible for damage to the customer's facility or equipment due to an improper and/or insufficient ground. **The customer's service entrance ground must be separate and independent from any JEA ground.**

2.22 CONDUCTOR IDENTIFICATION

The customer shall clearly mark each conductor of the service entrance as to phase, neutral and ground. At a minimum, the conductors shall be marked at the point of service and the location of the JEA metering transformers. Each conductor within JEA transformers and service boxes shall be "spiral" marked their entire length beginning at the conduit entering the equipment. Reference Sections 4.05, Commercial Services from Padmounted Transformers and 4.08, Underground Service from an Overhead Pole: Residential/Commercial; Figure 4.04A, Conduit/Service Box Installation (Commercial Service Multi-Metered Service) – UG Service from OH Pole and 4.04B, Conduit/Conductor Installation (Commercial Service 100 Amp Maximum) – UG Service from OH Pole;

The following color coding shall be used:

- For 240V: Neutral-White; Ground-Green; High Leg (3-phase 4-wire Delta service)-Orange.
- Phase markings for 208V: Black, Red and Blue.
- Phase markings for 480V: Brown, Orange and Yellow.

Any colors other than white, natural gray, green, or orange (other than 480V) may be used to identify the individual phases. All color-coding shall be consistent when parallel runs of conductor are used.

2.23 SECURITY OF SERVICE ENTRANCE

The customer's service entrance shall be secured against unauthorized electrical connection between the point of service and the point of metering.

When multiple services are tapped off of a common service entrance, such as in a wireway or switch gear, all removable covers shall be provided with a means for JEA Customer Field and Meter Services to install seals and/or locks.

The installation of metered conductors shall not be allowed in wireways containing unmetered conductors that are sealed by JEA.

2.24 SECURITY OF SERVICE EQUIPMENT AHEAD OF JEA POINT OF METERING

In some cases, a building with multiple electrical services requires the installation of a building service equipment main. The building service equipment main is located ahead of the JEA point of metering for the services, and therefore contains an unmetered service entrance. Such unmetered service equipment mains shall be located outside.

JEA Rules & Regulations For Electric Service
Chapter II General Service Information

In order to provide for the security of the service entrance, the building service equipment main shall be provided with a means for JEA Customer Field and Meter Services to install seals and/or locks on all removable covers. The installation of seals and/or locks behind covers attached by bolts or screws shall not be allowed. The installation of seals and/or locks may be allowed on covers that are behind easily accessible hinged doors.

If the building service equipment main is fusible, the fuses shall be accessible for maintenance through a non-sealed fuse access cover. The fuse access cover shall be separate from all other removable covers. The fuse access cover shall permit access only to the fuses. Neither the line nor load side conductors shall be accessible through the fuse access cover.

2.25 MAXIMUM LOSSES AHEAD OF JEA POINT OF METERING

The customer service entrance, located between the JEA point of service and the JEA point of metering, shall be sized to prevent a voltage drop in excess of 2% at the JEA point of metering.

(This Page Left Blank.)

Chapter III Secondary Metered Services – Overhead (0 – 600V)

(This page left blank.)

3.01 GENERAL

In areas where the existing distribution system is overhead, overhead service shall not be provided for any new permanent service.

Exception: A new permanent service may be served OH if **any** of the following apply:

- The new service is located in a multi-occupancy building with an existing OH service.
- The addition of the new service does not require a service increase for the existing service that would exceed the limitations for an OH service. Reference Table 2A, Available Secondary Service Voltages.
- The new service will be temporary for a period not to exceed two years at which time the service will need to be fed from the new single-family dwelling. Reference Sections 2.10, Variances.
- The new service is to feed an Environmental Protection (EP01) service.

OH service may be maintained for service increases, repairs and modifications that comply with Table 2A, Available Secondary Service Voltages.

Reference Section 2.01, Basic Requirements for Customer's Facility, 4.06, Special Requests for Padmounted Transformers and 4.08, Underground Service from an Overhead Pole: Residential/Commercial.

3.02 POINT OF SERVICE

The point of service for all overhead services is at the customer weatherhead (typically above JEA point of attachment) where the JEA service drop and customer service entrance conductors are connected. Reference Section 2.06, Service Location. Typical overhead service drop connections for residential, commercial and temporary services are shown in Figures 3.01 through 3.05.

3.03 SERVICE DROP CLEARANCES

It is the customer's responsibility to provide and maintain a suitable point of attachment for the JEA service drop. The point of attachment and the customer weatherhead shall be located such that the lowest point of sag of a new or replacement service drop shall be in accordance with the applicable minimum vertical clearance specified in the National Electrical Safety Code. At no time shall the JEA service drop be within 12 inches of any communication drop. The point of attachment and the customer weatherhead shall be located such that clearances from chimneys, antennas and satellite dishes are in compliance with NEC requirements.

JEA Rules & Regulations For Electric Service
Chapter III Secondary Metered Services – Overhead (0 – 600V)

Table 3A, Service Drop Requirements lists some of the most common clearance requirements. Reference Section 2.10, Variances and Figures 3.01 through 3.05.

If the nature of the customer's structure does not provide the clearance specified in Table 3A, Service Drop Requirements, the customer shall install a rigid galvanized steel (or IMC) mast or other supporting structure.. All supporting structures shall elevate the point of attachment to provide the specified clearance and provide mechanical support for the JEA service drop in accordance with applicable codes and local electrical inspection authority requirements. The support may **not** be used for any other attachments.

The customer shall provide 3 feet of excess service entrance conductors past the weatherhead or the JEA metering CTs to allow for proper termination of the service drop and the formation of a drip loop.

Table 3 A
Service Drop Requirements

WHERE SERVICE DROP CROSSES OVER (Drip loops are a part of the Service Drop)	MINIMUM REQUIRED VERTICAL CLEARANCE & POINT OF ATTACHMENT	NOTES
1. Residential areas accessible to pedestrians only	12 Ft	2, 4
2. Residential driveways	16 Ft	1, 2, 3,4
3. Commercial areas not subject to truck traffic	16 Ft	1, 2, 8, 10
4. Roads, streets, commercial driveways and other areas subject to truck traffic	18 Ft	1, 2, 9, 10
5. Roofs or balconies readily accessible to pedestrians	8 Ft	2, 5, 6
6. Roofs or balconies not readily accessible to pedestrians	3 Ft	2, 5, 6, 7
Notes:		
1.	Drip loops over areas subject to vehicle traffic are required to meet minimum vertical clearances. (The point of attachment and/or weatherhead must be raised accordingly.)	
2.	Where length of service drop will cause the sag to violate the above clearances, the point of attachment must be raised so that the low point of the service drop meets the minimum required vertical clearance.	
3.	Where the height of attachment to a residence does not permit service drop to meet these values, the clearance may be reduced to a minimum of 12 feet.	
4.	Minimum vertical clearance to drip loops is 10 feet.	
5.	Clearance measured to bottom of drip loop, or service drop, whichever is lower.	
6.	A roof or balcony is considered readily accessible to pedestrians if it can be casually accessed through a doorway, ramp, window, stairway, or permanently mounted ladder easily accessible.	
7.	If the service drop crosses 6 feet or less and the point of attachment is within 4 feet of the edge of the roof, the clearance may be reduced to a minimum of 18 inches. (This does not apply to mobile home roofs.)	
8.	Minimum vertical clearance to drip loops is 14 feet, if Note 1 does not apply.	
9.	Minimum vertical clearance to drip loops is 16 feet, if Note 1 does not apply.	
10.	Trucks are defined as any vehicle exceeding 8 feet in height.	

3.04 MOBILE HOME POLE / SERVICE POLE OH SERVICE

New Service: In order to receive a new permanent electric service to a mobile home the customer is responsible for installation of service lateral conduit to JEA facilities designated by JEA Electric Services. Reference Figures 4.04, Residential Service Lateral Conduit Installation – UG Service from OH Pole and 4.07, Meter Pedestal - UG Service 1 Phase & 3 Phase All Voltages Service Size: 400 Amp Maximum. For commercial services, reference Figures 4.04A, Conduit/Service Box Installation (Commercial Service & Multi-Metered Service) – UG Service from OH Pole and 4.07, Meter Pedestal – UG Service 1 Phase & 3 Phase All Voltages Service Size: 400 Amp Maximum. OH service may be maintained for existing services when the mobile home is replaced.

Existing or Replacement of Existing Service Drops: To prevent the service drop from crossing the mobile home, JEA may require the relocation or the replacement of the mobile home service pole if any of the following conditions occur, such that the installation meets the requirements of Section 3.03, Service Drop Clearances and Figure 3.04, Mobile Home Pole/Service Pole – OH Service:

- Replacement of both the line and load side of the service due to a service increase.
- Replacement of, or modification to, the mobile home that causes the service drop to violate the clearances as shown in Section 3.03, Service Drop Clearances.
- Replacement of the complete mobile home service pole.

Contact JEA Electric Services for further information and reference Section 2.06, Service Location.

3.05 UNDERGROUND SERVICE FROM AN OVERHEAD POLE

When an underground service from an overhead line is desired or required, reference Section 4.08, Underground Service from an Overhead Pole: Residential/Commercial.

3.06 TEMPORARY POWER POLE SERVICE

In order to receive temporary electrical service the customer is responsible for providing a temporary power pole as shown in and meet the requirements as noted in Figure 3.05, Temporary Pole - OH Service. Also reference Section 2.14, Temporary Service.

(This page left blank.)

Chapter IV Secondary Metered Services - Underground (0 – 600V)

(This page left blank.)

4.01 GENERAL

In areas where the existing distribution system is underground, where required by local governing bodies and all new permanent services; underground service must be used and overhead service will not be made available to the customer. The provisions of this chapter are applicable to all parts of the JEA service area except as may be modified in Chapter V, Downtown Underground Secondary Services.

NOTE: All connection and/or disconnection of secondary conductors in transformers, secondary pedestals, or pull boxes shall be performed only by JEA personnel or personnel under approved contract with JEA.

4.02 POINT OF SERVICE FROM AN UNDERGROUND DISTRIBUTION SYSTEM

Commercial: The point of service for all underground secondary services is the secondary terminals of the JEA service transformer or the terminals of the JEA secondary bus. Reference Section 2.06, Service Location.

Residential: The point of service is at the meter or at the JEA metering current transformer (CT). If the service is 400 amps or less, the point of service is at the meter. For services larger than 400 amps, the point of service is the line side of the CT(s); and the customer shall install conductors from the service equipment through the CT(s) in accordance with the NEC. The customer shall provide 3 feet of excess service entrance conductors past the JEA metering CT(s) to allow for proper termination of the service lateral.

Multi-Family: The point of service for all underground secondary services is the secondary terminals of the JEA service transformer. Reference Section 2.06, Service Location.

4.03 NEW UNDERGROUND DEVELOPMENTS

When a developer requests or is required to utilize an underground electrical distribution system within a development, JEA will provide the distribution system in accordance with the latest edition of the JEA Underground Electric Distribution Systems for Developments procedure.

https://www.jea.com/engineering_and_construction/electric_development/

Underground Commercial Development (UCD): An Underground Electric Distribution System where each Secondary Service Lateral supplies one or more commercial services. Business and/or industrial developments, commercial office parks, shopping centers, and arterial highways (not part of a URD or UAD) may qualify as a UCD.

Underground Multi-Family Development (UAD): An Underground Electric Distribution System where each Secondary Service Lateral supplies more than one electric meter (ganged meters) serving high density multi-family residential units such as apartments, condominiums and town-homes. Mobile home developments not meeting URD zoning requirements shall also fall in this category.

Underground Residential Development (URD): An Underground Electric Distribution System where each Secondary Service Lateral supplies a single meter serving a Single Family Residential Unit. Duplex residential dwellings typically qualify as a URD. Mobile home developments meeting zoning requirements may also qualify as a URD. Multi-Family Dwelling is a building containing three or four dwelling units located in low-rise, low-density subdivisions. The individual units may or may not be separated by four-hour firewalls.

4.04 SERVICE LATERALS IN UNDERGROUND RESIDENTIAL/APARTMENT DEVELOPMENTS

Definitions:

- **Underground Multi-Family Developments (UAD):**
An Underground Electric Distribution System where each Secondary Service Lateral supplies more than one electric meter, ganged meters.
- **Services within Underground Condominium Development:**
Considered to be same as an UAD. An Underground Electric Distribution System where each Secondary Service Lateral supplies more than one electric meter, ganged meters.
- **Services within Underground Townhome Development:**
Considered to be same as an UAD. An Underground Electric Distribution System where each Secondary Service Lateral supplies more than one electric meter, ganged meters.
- **Services within Underground Manufactured Home (Mobile Home) Development:**
If the mobile home development is not meeting URD zoning requirements shall be considered as an UAD. An Underground Electric Distribution System where each Secondary Service Lateral supplies more than one electric meter, ganged meters.
- **Services for Duplex Dwellings:**
They shall be considered as an URD with either 2 single meter sockets or two-gang meter socket on the structure.

Roles & Responsibilities:

Underground Residential Developments (URD): JEA will provide a 120/240V single phase 3 wire service lateral to the customer (single meter or qualified duplex only). The customer is required to supply and install conduit from the point of service to the JEA/developer installed conduit at the property line. If more than one 3 inch diameter conduit is required, JEA will provide an underground service box at the property line. JEA will maintain the service lateral conduit from the JEA source to the JEA end of the customer's service downpipe. Reference Figures 4.01, Residential Service Lateral Installation- UG Service (URD & UG Service from OH Pole); 4.02, Residential Service Lateral Conduit Installation – UG Service Residential Development (URD) – Service Size: 300 Amp Maximum; and 4.07, Meter Pedestal – UG Service – 1 Phase & 3 Phase All Voltages – Service Size: 400 Amp Maximum. JEA will

maintain the service lateral conductors from the JEA source to the point of service. Reference Figure 4.01, Residential Service Lateral Installation – UG Service (URD & UG Service from OH Pole). For mobile home installations within a URD, the meter socket will be installed on a pedestal approved by JEA Customer Field and Meter Services.

The conduit system requirements:

- Schedule 40 PVC, 3 inch diameter conduit (minimum). Chamfered edges required.
- Installation of a pull wire.
 - Note: all conduit exposed to damage must be Schedule 80
- All pull wires are to be multi-stranded poly twine. Use of nylon twine is not allowed.
- 30 inch minimum cover, 36 inch maximum cover from final grade to top of conduit. (Note: A gradual transition of the conduit to obtain appropriate cover will be required if the JEA/developer installed conduit is deeper than 36 inches. No 5 degree couplings, elbows, sweeps, etc. will be allowed.)
- Electrical marking tape (warning tape) to be installed 12 inches below finished grade.
- Conduit bends to be factory made sweeps with a radius of 36 inches. No more than 180 degrees of sweeps (total) may be installed between the point of service and the JEA/developer installed conduit (2 - 90 degree sweeps). We suggest most changes in direction and grade be accomplished by gradual deflection of the conduit. Reference Figure 4.01, Residential Service Lateral Installation – UG Service (URD & UG Service from OH Pole) for an example of a gradual bend created by heating and bending of conduit.
- Contact JEA Electric Services prior to installation if customer installed conduit from the customer point of service to the JEA padmounted transformer or to the JEA pole totals 300 feet or more.
- We recommend that the conduit installation begin at the end of the JEA/developer installed conduit and progress towards the point of service.
- JEA recommends that the service lateral conduit be installed prior to the "Cover Up" inspection.
- **Underground Apartment Developments (UAD):** JEA will provide a 120/240V single phase 3 wire service. The customer shall install and maintain the secondary service lateral from the JEA's point of service to the Customer's meter center. To prevent multiple outages JEA requests that multiple buildings served from one transformer have all services installed and inspected at the same time.

4.05 COMMERCIAL SERVICES FROM PADMOUNTED TRANSFORMERS

In areas served by an overhead distribution system, JEA shall provide service from a padmounted transformer to any customer with an electrical service meeting the **MINIMUM DEMAND** requirements for padmounted transformers given in Table 2A, Available Secondary

JEA Rules & Regulations For Electric Service
Chapter IV Secondary Metered Services - Underground (0 – 600V)

Service Voltages. JEA requires the customer to receive service from a padmounted transformer when the customer's secondary services exceeds the **MAXIMUM SERVICE SIZE** for service underground from pole as given in Table 2A, Available Secondary Service Voltages.

All customers within Underground Commercial Developments will be served by padmounted transformers. NOTE: Table 2A, Available Secondary Service Voltages applies.

To determine the particular requirements for service installation contact JEA Electric Services. At a minimum the customer is required to provide the following:

- Description of customer's installation as required in Section 2.02, Description of Customer's Installation.
- Any required easements.
- Conduit routing as required by JEA. The customer may be required to install conduits to property line(s) to provide for future extensions.
- Manholes installation (sized and located as required by JEA). Duct rotation shall be maintained throughout the system.
- Installation of two or more, 4 inch diameter, Schedule 40 PVC conduits for each JEA primary circuit installed. Conduits shall have chamfered edges and be installed a minimum of 42 inches below finished grade and shall be provided with 90 degree 36 inch radius elbows, warning tape and pull wire. (Pull wire is to be multi-stranded poly twine. Use of nylon twine is not allowed.)
- Installation of transformer pad(s) in accordance with JEA specifications. Reference Figures 4.03A, Transformer Pad Detail – UG Service – 75-500 kVA, 3 Phase; and 4.03B, Transformer Pad Detail – UG Service – 750-3750 kVA, 3 Phase.
- Guard structures, two per each side of the transformer exposed to vehicular traffic, shall consist of 6 inch diameter by 8 foot long galvanized steel or black iron pipe mounted in and filled with concrete. The pipe shall be mounted 4 feet below grade with 4 feet extending above grade. The above grade portion shall be painted DOT yellow. Reference Figure 4.03C, Bollard Detail.
- The secondary service lateral meeting the below referenced requirements:
 - ♦ Each service connected by JEA shall have a neutral.
 - For all 1 phase transformer installations:
 - ♦ 3' of excess cable above the top of the pad.
 - ♦ The maximum allowable secondary size is 500 MCM
 - For 3 phase transformer installations:
 - ♦ 75 kVA transformers: 6' of excess cable above the top of the pad.
 - ♦ 150, 300 and 500 kVA transformers: 7' of excess cable above the top of the pad.
 - ♦ 750, 1000, 1500, 2500 and 3750 kVA transformers: 8' of excess cable above the top of the pad.
 - ♦ The maximum allowable secondary size is 750 MCM

JEA Rules & Regulations For Electric Service
Chapter IV Secondary Metered Services - Underground (0 – 600V)

NOTE: "On new transformer installs the secondary conductor shall not be installed in conduit until the JEA transformer has been placed on the pad."

JEA will provide the following:

- Marked copy of the customer's plan showing size and number of conduits, conduit routing, manhole location and transformer locations.
- Transformer(s).
- Primary cables.
- Primary and secondary cable terminations in the transformer.

JEA considers the primary voltage materials furnished and installed by the customer to be contribution-in-aid-of-construction. Furthermore, in the case where new load is involved, a Non-Standard Service Revenue Allowance (NSRA) is applicable. Thus, when new load is involved, JEA will also furnish the following as application of the NSRA:

- Manholes.
- Primary conduit.
- Transformer pad.

It is the customer's responsibility to maintain and/or replace manholes, primary conduit and transformer pads located on the customer's property.

Current Transformer 3 Phase Padmounted Service: Where only one underground service, 3 phase 4 wire greater than 400 amps, is fed from a padmounted transformer, the current transformers (CTs) may be installed in the transformer. Upon customer request, JEA Electric Services will consider allowing the use of a single CT set and meter for multiple electrical services where all such services are the responsibility of the same customer. In such cases, any subsequent metering modifications caused by future customer action will be at the sole expense of the customer. The customer must contact JEA Electric Services to determine the particular requirements for this service installation. Reference Figure 4.03, Current Transformer Padmounted Installation – 3 Phase UG Service.

4.06 SPECIAL REQUESTS FOR PADMOUNTED TRANSFORMERS

Commercial Services: In areas served by an overhead distribution system, customers not meeting the minimum requirements for service from a padmounted transformer may request JEA to provide service from a padmounted transformer. In addition to the requirements of Section 4.05, Commercial Services from Padmounted Transformers, the customer will be required to provide a contribution-in-aid-of-construction. Reference Section 1.05, Apportionment of Costs for JEA System Extensions, Additions and Modifications.

Residential Services: In areas served by an overhead distribution system, customers may request JEA to provide service from a padmounted transformer. The customer is required to install a conduit system in accordance with the JEA Procedure for Underground Conduit

Systems. Reference Section 4.04, Service Laterals in Underground Residential/Apartment Developments. The customer will be required to provide a contribution-in-aid-of-construction for all JEA costs in excess of the cost to install overhead facilities. Reference Section 1.05, Apportionment of Costs for JEA System Extensions, Additions and Modifications.

4.07 CUSTOMER'S RESPONSIBILITY TO PROTECT PADMOUNTED EQUIPMENT

In addition to the requirements of Section 1.08, Protection by Customer of JEA Property, the customer shall provide protection for JEA padmounted equipment that is installed adjacent to parking lots or driveways. At a minimum, the method of protection shall be as stated in Section 4.05, Commercial Services from Padmounted Transformers.

4.08 UNDERGROUND SERVICE FROM AN OVERHEAD POLE: RESIDENTIAL/COMMERCIAL

JEA shall provide connection to an underground service from an overhead pole for new permanent services. Reference Figures 4.04, Residential Service Lateral Conduit Installation – UG Service from OH Pole and 4.04A, Conduit/Service Box Installation (Commercial Service & Multi-Metered Service) - UG Service from OH Pole.

Residential: (single meter) The customer is required to install a service lateral conduit to a JEA pole designated by the JEA Service Engineer and in accordance with Sections 4.04, Service Laterals in Underground Residential/Apartment Developments and 4.02, Point of Service from an Underground Distribution System; and Figures 4.01, Residential Service Lateral Installation – UG Service (URD & UG Service from OH Pole) and 4.04, Residential Service Lateral Conduit Installation – UG Service from OH Pole.

Commercial and Multiple Metered Residential/Apartments: When JEA provides underground service from an overhead pole, the point of service is in a JEA service box located on the customer's property. If JEA deems the installation of a pole on customer property necessary, the customer is required to provide JEA with appropriate easements and unrestricted access for maintenance. Reference Figure 4.04A, Conduit/Service Box Installation (Commercial Service & Multi-Metered Service) – UG Service from OH Pole.

To determine the specific requirements for each service, contact JEA Electric Services. At a minimum, the customer is required to provide the following:

- Description of customer's installation as required by Section 2.02, Description of Customer's Installation.
- The service pole and service box locations will be designated by the JEA Service Engineer. Normally, the service box will be located on customer property adjacent to the JEA service pole. The maximum distance from JEA pole to service box shall be 10', or as designated by the JEA Service Engineer.
- Any required easements.

JEA Rules & Regulations For Electric Service
Chapter IV Secondary Metered Services - Underground (0 – 600V)

- Service box as specified in Table 4A, Conduit and Service Box Requirements for Underground Commercial Services from an Overhead Pole. (If new load is involved, JEA will furnish as application of Non-Standard Service Revenue Allowance. Reference Section 1.05, Apportionment of Costs for JEA System Extensions, Additions and Modifications.)
- Conduits to be mounted on the building side and clear side of service pole and terminated in the service box (size & number as identified in Table 4A, Conduit and Service Box Requirements for Underground Commercial Services from an Overhead Pole). (Note: Empty conduit ends shall be plugged.) Chamfered edges are required.
- Three (3) feet of excess service entrance conductors coiled up in the service box to allow for proper termination of the service lateral.
- The service box may not be located in an area subject to vehicular traffic.
- JEA recommends that the service lateral conduit be installed prior to the "Cover Up" inspection.

EXCEPTION: Commercial Services, 100 Amps or less will be installed as outlined in Figure 4.04B, Conduit/Conductor Installation (Commercial Service 100 Amp Maximum) – UG Service from OH Pole.

4.09 TEMPORARY SERVICE

A typical Underground Temporary Pole arrangement for maximum 400 amp URD services is shown in Figure 4.05, Temporary Pole (400 Amp Maximum) – UG Service. The customer is required to install the service lateral from the temporary pole into the JEA secondary compartment (i.e.; transformer, pedestal, or pull box). Temporary poles shall be placed on the right side (as you face the transformer) for service from 1 phase transformers. For open delta banks, the temporary pole must be placed on the left side (facing the transformer) of the bank. In both cases, service conductors must run to the right side (secondary service side) of the compartment. JEA will connect the service conductors in the secondary compartment. The arrangement shown in Figure 4.05a applies to the flat rate temporary services in Duval County but there is no need for the meter can. In the case of older temporary poles, jumpers installed in the meter can are acceptable if the proper pie plate installed.

A typical Underground Temporary Service arrangement for maximum 100 amp URD services is shown in Figure 4.06, Temporary Service Pole (100 Amp Maximum) – UG Service. **This installation is not allowed in St. Johns County.** The customer is required to install the permanent service lateral conduit and JEA will install the permanent service lateral conductors in accordance with Section 4.04, Service Laterals in Underground Residential/Apartment Developments. The customer is also required to install the conduit and temporary service lateral conductors (aluminum conductors only) between the meter sockets. The temporary service lateral conductors will be connected under the line side meter socket lugs along with the permanent service lateral conductors by JEA Electric Services. The load side lugs will be free so the customer can run the service entrance cable to the main panel when ready. The JEA

meter technician installing the permanent meter will remove the temporary service lateral conductors from the line side lugs, tighten the lugs and cut the temporary service lateral conductors flush with the 1 inch conduit in the permanent meter socket. The temporary pole can be removed by the customer after the temporary meter is removed. The customer is responsible for removing the temporary service lateral conductors from the one inch conduit, cutting this conduit just past the footing and gluing a cap on the end of the remaining one inch conduit.

Temporary service for URD services greater than listed above shall be treated on an individual basis. Contact JEA Electric Services to determine the particular requirements for installation.

When permanent service will be provided from a three phase padmounted transformer, the customer may request JEA to install the permanent service transformer prior to building completion to supply temporary service. Reference Section 2.14, Temporary Service.

4.10 OVERHEAD TO UNDERGROUND SERVICE CONVERSION

In areas served by an overhead distribution system and **no** increase in load, the customer may elect to convert their existing overhead service to an underground service utilizing the method outlined in Figure 4.01C, Overhead to Underground Conversion of Existing Residential Service with No Increase in Service Size. The following criteria must be observed before JEA will proceed with the installation of the underground service:

- Please contact the appropriate Service Engineer referenced in Appendix B for the approval of this type of underground conversion.
- **No** increase in service.
- Use only JEA approved boxes:
Millbank Box - #55L90-3R-SP1 for all Residential House Services
Millbank Box - #5518-GSC3R-SP1 for all Residential Trailer Services
- Meter Lugs must be large enough to accommodate 2/0 underground cable.

JEA Rules & Regulations For Electric Service
Chapter IV Secondary Metered Services - Underground (0 – 600V)

**TABLE 4A
CONDUIT AND SERVICE BOX REQUIREMENTS
FOR UNDERGROUND COMMERCIAL SERVICES FROM AN OVERHEAD POLE**

SERVICE SIZE	CONDUIT SIZE (From Service Box to JEA Overhead Pole)	SERVICE BOX SIZE
20A -200A	(1)-3 in	17" x 30" x 18" d stock #BOX SE 001
201A - 399A	(1)-3 in	24" x 36" x 18" d stock #BOX SE 002
400A-800A	400A=(1)-4 in 401-800A=(2)-4 in	30" x 48" x 24" d manhole stock #MANHO 007
801A-1200A	801-1000A=(2)-4 in 1001-1200A=(3)-4 in	36" x 60" x 36" d manhole stock #MANHO 005
<p>NOTE:</p> <ol style="list-style-type: none"> All conduits to be Schedule 40 PVC with chamfered edges required. Conduit size and number does not have to match customers' service conduit size, type and number. All conduit radiuses to be 36 inch minimum. JEA will allow the option of purchasing these boxes from an electrical supply house. These boxes must meet the following specifications. Service box size may vary for 3 phase applications. Contact the JEA Service Engineer for conduit and box location. 		
<p>Technical Specifications</p>		
<p>Material Specifications:</p> <p>SERVICE BOX</p> <ol style="list-style-type: none"> Top: Compression molded polymer concrete with minimum thickness of two inches. Body: Reinforced Plastic Mortar (RPM) consisting of fiberglass and isopholic resin. The base will have a flange of two inches from the inside wall. Ring: The ring will be of polymer concrete and will be permanently fused to the body during the curing process. <p>MANHOLE</p> <ol style="list-style-type: none"> Manhole Body shall be of one piece construction with a solid cover. Manhole dimensions shall be 60" l x 36" w x 36"d. <p>Load Rating:</p> <ol style="list-style-type: none"> Load Rating: H-10 (Incidental Traffic). Load ratings shall be in accordance with ASTM, C-857-87 (STD. PRACTICE FOR MINIMUM STRUCTURAL DESIGN LOADING FOR UG PRECAST CONCRETE UTILITY STRUCTURES) Ashto and Western Underground Committee Recommended Guidelines Rule 3.6 dated 6-15-87. <p>Miscellaneous Requirements:</p> <ol style="list-style-type: none"> Hardware: Two captive stainless penta head bolts for securing top. Bolt heads will be flush with top of cover. Identification: Each top will have the word "ELECTRIC" permanently marked into the top. 		

(This page left blank.)

Chapter V Downtown Underground Secondary Services

(This page left blank.)

5.01 GENERAL

The Network Service Area and the Underground Service Area shall be as shown in Figures 5.01A & 5.01B, Downtown Service Area Boundary Map. JEA shall provide either Network or Spot-Network services within the Network Service Area. Underground Secondary Service will be provided within the Downtown Service Area. The type of service provided will depend upon the customer's location and electrical load characteristics. This chapter presents the requirements for Network and Spot-Network services. This chapter also presents supplemental requirements to Chapter IV, Secondary Metered Services-Underground (0 - 600V), for Underground Secondary Services installed in the Downtown Service Area.

Since the Downtown Service Area is a critical growth and transition area, the customer is required to contact JEA Electric Services before planning either a new service or changes to an existing service within this area. Most of the JEA distribution system in the Downtown Service Area consists of a manhole and duct bank system. Alterations and additions to this system generally require a great deal of time. Therefore, it is recommended that the customer contact JEA Electric Services during the initial planning phase to assure the timely installation of the distribution electrical system to assure that service will be available when required.

5.02 POINT OF SERVICE

The point of service for customers served from the JEA 120/208V Network Distribution System is at a JEA manhole in the right-of-way adjacent to the customer's property. The point of service for customers served from a JEA 277/480V Spot-Network is the load terminals of the JEA network protector. The network protector is mounted on the JEA Spot-Network transformer.

Point of service for Underground Secondary Services:

- Described in Chapter IV, Secondary Metered Services - Underground (0 - 600V).
- Location will be as designated by JEA. Reference Section 2.06, Service Location.

5.03 NETWORK SERVICE AREA LOAD RESTRICTIONS

The maximum size service that JEA will serve from the 120/208V Network or a 277/480V Spot-Network distribution system is as stated in Section 2.11, Service Voltages Available. Since excessive demands may create system conditions that adversely affect service to other customers, customers with a demand exceeding the maximum stated shall be required to take corrective action. This action may include controlling demand to levels below the maximum, requesting a second point of service, or changing the customer's service to Spot-Network or Primary Metered Service.

A customer with an initial demand less than the minimum required demand for Spot-Network service may request a Spot-Network service when future load increases are expected to exceed the minimum requirements. Depending on the customer's initial demand, development

schedule, JEA equipment requirements and other factors; JEA may require the customer to provide a contribution-in-aid-of-construction for Spot-Network service.

Since the cost to the customer to increase service capacity in the Network Service Area can be substantial, the customer should carefully evaluate the demand potential of the customer's facility before requesting service. JEA Electric Services shall review each case on an individual basis.

5.04 LOAD BALANCE

The Network customer is required to maintain a balanced load such that the difference in current flow between the highest and lowest phase does not exceed 15%.

5.05 CUSTOMER SERVICE EQUIPMENT

Network customers are required to provide service equipment with a minimum interrupting capacity of 65,000 amps at 240V. Spot-Network and Underground Secondary Service customers shall contact JEA Electric Services to determine the interrupting capacity of the customer's service equipment.

For Network services above 200 amps, the customer is required to provide a circuit breaker main. Network services of 200 amps and below may use a fusible service equipment main rather than a circuit breaker. Fuses shall be Class J. For Services greater than 400 amps, the customer shall provide for the installation of the JEA metering current transformers (CTs) on the line side of the customer service entrance main.

Reference Sections 2.22, Security of Service Entrance; 2.23, Security of Service Equipment Ahead of JEA Point of Metering and 7.05, Point of Metering.

5.06 NETWORK SERVICE CONNECTION REQUIREMENTS

Network customers shall furnish, install and maintain the secondary service entrance from the JEA point of service to the customer's service equipment. To determine the specific customer requirements for each service, contact JEA Electric Services. At a minimum, the customer is required to provide the following:

- Description of customer's installation as required by Section 2.02, Description of Customer's Installation.
- Any required easements.
- Service entrance consisting of conductor or bus duct. The installation of bus duct shall be restricted to indoors.
- Copper conductors with insulation rated for wet locations and a temperature rating of at least 75 degrees Centigrade.
- Conductors installed in multiple runs of 500 KCM. Services less than the ampacity of a single run of 500 KCM shall be a single run of the conductor size as required.

- When conductors are paralleled, JEA will provide a cable limiter type fuse on the manhole end of each service entrance conductor.
- One conduit per paralleled run of service entrance conductors from the customer's building into the JEA manhole. Conduit diameter sizes are limited to whole number sizes; the use of half numbers is not allowed.
- Slack service entrance conductor in JEA manhole for termination by JEA. Verify length required with JEA.
- JEA will provide access into the JEA manhole for customer installation of the service entrance conduits. The conduits must be installed flush with the inside wall of the JEA manhole and securely bundled together with space between conduits to allow for grouting. Coordinate the installation with JEA Electric Services. The customer shall perform the installation without damage to JEA property.

5.07 SPOT-NETWORK CUSTOMER SERVICE REQUIREMENTS

The Spot-Network customer shall furnish, install and maintain a primary conduit system, transformer vault and secondary service entrance. To determine the specific requirements for each service, contact JEA Electric Services. At a minimum, the customer is required to provide the following:

- Description of customer's installation as required by Section 2.02, Description of Customer's Installation.
- Any required easements.

PRIMARY CONDUIT SYSTEM

- Conduit routing as required by JEA.
- Installation of manholes (furnished, sized and located as required by JEA).
- Installation of two or more, 4 inch diameter, Schedule 40 PVC conduits (furnished by JEA) for each JEA primary circuit installed. Conduits shall have chamfered edges and be installed a minimum of 42 inches below finished grade and shall be provided with a pull wire. (Pull wire is to be multi-stranded poly twine. Use of nylon twine is not allowed.)
- Primary conduit system designed and installed in accordance with the latest edition of the National Electrical Safety Code (NESC), Part 3, Section 32, Underground Conduit Systems.
- Primary conduit system design documents, including a statement of conformance to NESC requirements, submitted to JEA Electric Services under the seal of a Professional Engineer registered in the State of Florida.
- JEA will provide access into the JEA manhole for customer installation of the service entrance conduits. The conduits must be installed flush with the inside wall of the JEA manhole. The conduits shall be securely bundled together with space between conduits to allow for grouting. Coordinate the installation with JEA

Electric Services. The customer shall perform the installation without damage to JEA property.

TRANSFORMER VAULT

- Transformer vault designed and constructed in accordance with the latest edition of the National Electrical Code (NEC) Article 450, Part C, Transformer Vaults.
- Transformer vault located at ground floor or basement level and sized to allow for installation, maintenance and replacement of JEA transformers and equipment.
- Transformer vault constructed and maintained to provide a dry environment and sufficient filtered ventilation for proper transformer cooling.
- Uniform lighting level within the transformer vault of 70 foot-candles maintained.
- Light switches at each entrance into the transformer vault.
- 20 amp 120V power outlets located within the transformer vault as required by JEA.

SECONDARY SERVICE CONNECTION

- Bus duct cable tap boxes, one for each transformer, phased as required by JEA.
- 500 KCM copper secondary service entrance conductors connected to bus duct cable tap box. All conductors shall be the same length.
- Conductor insulation rated for wet locations and a temperature rating of at least 75 degrees Centigrade.
- Current limiting bus limited to installation behind the JEA point of metering.
- JEA will connect service entrance conductors to the JEA Network Protector.

5.08 CUSTOMER'S RESPONSIBILITY TO MAINTAIN SPOT-NETWORK TRANSFORMER VAULT

The Spot-Network transformer vault shall be reserved strictly for the housing of the JEA Spot-Network transformers and associated electrical service equipment. No customer use of the JEA Spot-Network transformer vault shall be allowed.

The customer is responsible for maintaining the luminaries and lamps, electrical power outlets, ventilation system (including air filters) and general transformer vault conditions in accordance with the requirements of these Rules and Regulations.

The customer is responsible to provide 24 hour 7 day a week access for maintenance, emergency and/or routine work. JEA will provide a mortise-type lock for egress doorway, holders of keys shall be limited to authorized JEA personnel. If possible, the vault door shall directly access the outside of the building.

5.09 SERVICE FROM PADMOUNTED TRANSFORMERS

Within the Underground Service Area, JEA shall normally provide the customer with secondary service from a padmounted transformer. Service from a padmounted transformer shall be provided in accordance with the requirements of Section 4.05, Commercial Services from Padmounted Transformers.

5.10 UNDERGROUND SERVICE FROM AN OVERHEAD POLE

JEA Electric Services may require customers in the Network Service Area or Underground Service Area to receive underground secondary service from an overhead pole. When underground service from an overhead pole is required, installation shall be in accordance with the requirements of Section 4.08, Underground Service from an Overhead Pole: Residential/Commercial.

In addition to the requirements of Section 4.08, Underground Service from an Overhead Pole: Residential/Commercial, JEA Electric Services may impose any of the following special requirements. These special requirements are to allow the customer to be converted to a Network feed at a later date.

- The customer's service size and voltage must meet the Network/Spot-Network requirements in Table 2A, Available Secondary Service Voltages.
- The customer's service entrance conductors shall be copper.
- The customer's service entrance conductors shall be installed in conduit.
- The customer's service equipment shall comply with the requirements of Section 5.05, Customer Service Equipment.

5.11 NEW UNDERGROUND DEVELOPMENTS

In existing areas of overhead distribution, JEA shall provide service to new developments in accordance with the requirements of Chapter IV, Secondary Metered Services-Underground (0 - 600V).

5.12 OVERHEAD SERVICE

JEA may provide overhead service within the limits given in Section 2.11, Service Voltages Available, under either of the following conditions:

- The Downtown Development Authority has identified a customer's property for future demolition.
- Providing an underground service would require unreasonable expenditures by either the customer or JEA.

5.13 TEMPORARY SERVICE

Due to the nature of the construction of the JEA distribution system in the Downtown Service Area and the length of time required to make additions to the system, the customer is required to contact JEA Electric Services well in advance of the time temporary service will be required. Not all voltages will be available for temporary service.

Reference Section 2.14, Temporary Service.

(This page left blank.)

Chapter VI Primary Metered Services

(This page left blank.)

6.01 GENERAL

JEA will provide primary voltage distribution or transmission service in accordance with Electric Documentation, Vol. 1, Rate Schedule GSLD. JEA will provide primary voltage service to any customer meeting JEA's minimum demand requirements stated in Table 2B, Available Primary Service Voltages.

The primary service customer is required to provide and maintain the transformation and distribution system within the customer's facility. As specified in Section 1.05, Apportionment of Costs for JEA System Extensions, Additions and Modifications, the customer may be required in some cases to reimburse JEA for some or all of the cost associated with extending JEA's existing distribution and/or transmission lines to the customer's service location.

Primary voltage level, point of service, meter location and JEA service entrance construction shall be as determined by JEA Electric Services. Electrical energy consumption shall be measured at the voltage at which service is rendered.

All new primary metered services shall be installed underground.

6.02 EXISTING PRIMARY METERED CUSTOMERS

JEA encourages existing primary metered customers to convert all or a portion of existing primary metered load(s) and connect any new load to secondary service provided by JEA. The customer may be required in some cases to reimburse JEA for some of the costs associated with providing secondary service and extending JEA's existing distribution and/or transmission lines to the customer's service location. The customer's cost participation shall be based on JEA's Primary to Secondary Conversion Policy.

6.03 CUSTOMER SERVICE EQUIPMENT

The customer is responsible for providing service equipment that is acceptable to the local inspection authority and to JEA Electric Services. The service equipment shall be located as close to the point of service as possible and shall provide for separation of the customer from the JEA system in the event of a fault or overload on the customer system.

The service equipment shall provide the following minimum ratings for the primary distribution voltages shown in Table 6A, Service Equipment Requirements for Primary Service.

The customer shall submit a complete description of the service equipment to include equipment rating and the time current characteristics to JEA Electric Services for approval. JEA will provide the upstream overcurrent protective device settings with which the customer must coordinate.

Table 6A
SERVICE EQUIPMENT REQUIREMENTS FOR PRIMARY SERVICE

	7,620/13,200 V	15,200/26,400 V
Voltage Rating	15 kVA	27 kVA
KVA Bil	110 kVA	150 kVA
Interrupting Capacity	*	*

* Fault current information will be provided upon request by JEA System Planning.

6.04 POINT OF SERVICE

Unless otherwise stated by JEA Electric Services, the point of service for primary metered service customers will be the load side of the JEA revenue metering installation.

The location of the point of service will be designated by JEA, reference Section 2.06, Service Location.

6.05 OVERHEAD SERVICE

Overhead service is not available for new primary metered services.

A typical overhead primary metered service is shown in Figure 6.01, Primary Metering Installation – Existing OH Service. The primary meter poles are normally located in an easement on the customer's property adjacent to the public right-of-way. Appropriate easements and unrestricted access for JEA personnel and equipment shall be provided and maintained.

The metering pole and all metering equipment will be supplied, installed and maintained by JEA.

6.06 UNDERGROUND SERVICE PADMOUNTED METERING TRANSFORMERS

A typical underground padmounted primary metered service is shown in Figure 6.02, Primary Metering Padmounted Installation – UG Service. The padmounted meter shall be located in an easement on the customer's property adjacent to the public right-of-way. Appropriate easements and unrestricted access to JEA personnel and equipment shall be provided and maintained.

To determine the specific requirements for service installation, contact JEA Electric Services. At a minimum, the customer is required to provide the following:

- Description of customer's installation as required by Section 2.02, Description of Customer's Installation.
- Any required easements.

JEA Rules & Regulations For Electric Service
Chapter VI Primary Metered Services

- Primary metering pit for the JEA installation of padmounted metering cabinet in accordance with JEA Underground Construction Standards.
- Guard structures, two per each side of the padmounted metering cabinet exposed to vehicular traffic, shall consist of 6 inch diameter by 8 foot long galvanized steel or black iron pipe mounted in and filled with concrete. The pipe shall be mounted 4 feet below grade with 4 feet extending above grade. The above grade portion shall be painted DOT yellow. Reference Figure 4.03C, Bollard Detail.
- Two or more, 4 inch Schedule 40 PVC conduits for each primary circuit from the metering pit to a point on the right-of-way as designated by JEA Electric Services. Conduits must have chamfered edges.
- Conduits installed 42 inches below finished grade provided with 90 degree 36 inch radius elbows, warning tape and pull wires. (Pull wire is to be multi-stranded poly twine. Use of nylon twine is not allowed.)
- Primary voltage service entrance cable complete with elbow type terminators suitable for connection to the JEA metering terminals.
- Driven ground rods that provide a maximum resistance to ground of 25 ohms.
- Installation of the meter enclosure and instrument transformer secondary raceway between the metering cabinet and meter enclosure. JEA Commercial Meter Services will approve the location of the meter enclosure. Reference Sections 7.10, Raceways for Instrument Transformer Secondaries and 7.12, Location of Meters.

JEA will furnish and install the padmounted metering cabinet, metering transformers and connection from the metering pit to the JEA primary distribution. Metering equipment will be furnished and installed in accordance with the requirements of Chapter VII, Meters and Metering Equipment.

6.07 UNDERGROUND SERVICE SWITCHBOARD MOUNTED METERING TRANSFORMERS

When a padmounted metering installation is not practical, with prior approval the JEA metering transformers shall be mounted in a metering cubicle in the customer's switchboard. For this type of service, the JEA point of service to the customer will be the JEA primary cable in the metering cubicle.

To determine the specific requirements for service installation, contact JEA Electric Services. At a minimum, the customer is required to provide the following:

- Description of customer's installation as required by Section 2.02, Description of Customer's Installation.
- Any required easements.
- Conduit routing from a point of connection in the public right-of-way to the customer's switchboard metering cubicle as required by JEA.
- Manholes sized and located as required by JEA.

JEA Rules & Regulations For Electric Service
Chapter VI Primary Metered Services

- Two 4 inch diameter, Schedule 40 PVC conduits for each JEA primary circuit installed. Conduits shall have chamfered edges and be installed a minimum of 42 inches below finished grade and shall be provided with 90 degree 36 inch radius elbows, warning tape and pull wire. (Pull wire is to be multi-stranded poly twine. Use of nylon twine is not allowed.)
- Cable terminators in the metering cubicle for JEA primary cable.
- A method, acceptable to JEA, to isolate metering transformers and customer lightning arresters from JEA primary cable to permit JEA cable testing.
- Security of metering cubicle and installation of metering transformers, meter enclosure and instrument transformer secondary raceway in accordance with the requirements of Chapter VII, Meters and Metering Equipment.

JEA will furnish and install primary cable from the existing JEA distribution system into the metering cubicle. Metering equipment will be furnished and installed in accordance with the requirements of Chapter VII, Meters and Metering Equipment. If requested by the customer, JEA may provide the metering transformers to the customer for transportation to the customer's switchboard manufacturer for installation. Prior approval of the transformers mounting location within the switchboard by JEA Commercial Meter Services is required.

6.08 UNDERGROUND SERVICE NETWORK SERVICE AREA

Within the Network Service Area, as shown in Figures 5.01A & 5.01B, Downtown Service Area Boundary Map, primary service shall be underground. Due to the design and operation of this system, JEA shall require primary service customers to receive service from two different primary circuits. The customer shall not consider either circuit to be dedicated to the service of the customer.

In addition to the minimum customer requirements stated in Section 6.07, Underground Service Switchboard Mounted Metering Transformers, customers in the Network Service Area shall, at a minimum, provide the following:

- Primary conduit system designed and installed in accordance with the latest edition of the National Electrical Safety Code (NESC) Part 3, Chapter 32, Underground Conduit Systems.
- Primary conduit system design documents, including a statement of conformance to NESC requirements, submitted to JEA Electric Services under the seal of a Professional Engineer registered in the State of Florida.
- JEA shall provide access into the JEA manhole for customer installation of the service entrance conduits. Conduit diameter sizes are limited to whole number sizes; the use of half numbers is not allowed. The conduits must be installed flush with the inside wall of the JEA manhole and securely bundled together with space between conduits to allow for grouting. Coordinate the installation with JEA Electric Services. The customer shall perform the installation without damage to JEA property.

Chapter VII Meters and Metering Equipment

(This page left blank.)

7.01 GENERAL

JEA will provide for the metering of each customer's electrical service. The metering equipment shall measure the electrical power flowing through the service of each customer in the units of measure as required by the appropriate JEA Rate Schedule.

The customer is required to install meter sockets and/or enclosures, instrument transformers, and safety test blocks. JEA will furnish, install, and maintain the required meters, metering devices, and secondary wiring between the instrument transformers, meters and metering devices. The customer is responsible for providing the meter sockets and associated metering accessories for all self-contained services (up to and including 400 amps. ALL VOLTAGES). Reference Section 7.04, Meter Socket Specifications.

CTs, CT meter enclosures and CT metering accessories will be issued by JEA at no charge. (CT Cabinets are not provided by JEA.) An electrical permit will be required to issue meter sockets, enclosures and metering accessories. Metering equipment furnished by JEA for customer installation may be obtained from the JEA Storeroom located at 6674 Commonwealth Avenue. No equipment will be issued after the expiration date of the permit.

On multi-metered services (i.e.; meter centers), the maximum number of meter seals that will be replaced on any one electrical permit is 4. Additional permits will have to be issued based on the number of cut meter seals, 4 per permit (i.e.; 9 cut meter seals would require 3 separate electrical permits).

Metering equipment shall be installed as described in this chapter and as shown in Figures 6.01, 6.02 and 7.01 through 7.13. Additional requirements are given in Chapter II, General Service Information; Chapter III, Secondary Metered Services-Overhead (0 - 600V); Chapter IV, Secondary Metered Services-Underground (0 - 600V) and Chapter VI, Primary Metered Services.

7.02 METER TAMPERING

Only duly authorized agents of JEA or persons authorized by law may install or remove, turn on or turn off, or make any changes to any part of the JEA metering installation which may affect the accuracy of measurements. Unauthorized connection to or tampering with the JEA metering equipment or the JEA seals placed on the equipment, or connection to unmetered service entrance conductors ahead of the metering equipment, subjects the customer to discontinuance of service, prosecution under the laws of the State of Florida, civil litigation, adjustment of prior bills for service rendered and reimbursement to JEA for all extra expenses incurred including any tampering charges in effect at the time of the event.

7.03 TYPES OF METERING SYSTEMS

In order to meter the electrical power consumed by the customer, JEA must measure both the current flowing to the customer and voltage level at which the current is flowing.

JEA meters services 400 amps and below using self-contained meters. All secondary metered services > 200 amps ≤ 400 amps require installation of the 320 amp meter socket.

When self-contained meters are used, the customer's service entrance is connected directly into the meter socket terminals. The line voltage is applied to the meter and full load currents flow through the meter.

Secondary services above 400 amps and all primary metered services require instrument transformers to transform line currents and voltages (for primary service) to measure magnitudes.

When an existing secondary current transformer (CT) rated service is repaired, modified, or upgraded the service must be brought into accordance with these Rules and Regulations for Electric Service.

If the line side service conductors are replaced and the current transformers (CTs) have been in service for 5 years or more, new CTs shall be installed. (This information is available through JEA Commercial Meter Services.) If the transformer is located in the main switch or in a wireway, a CT cabinet must be installed. Transformers and meter sockets will be supplied by JEA.

All secondary raceways must be installed and maintained in accordance with Section 7.10, Raceways for Instrument Transformer Secondaries.

If the meter enclosure is an A-base type it must be changed to socket type.

7.04 METER SOCKET SPECIFICATIONS

The customer is responsible for providing the meter sockets and associated metering accessories for all self-contained services (up to and including 400 amps, ALL VOLTAGES).

- Meter sockets shall have a label certifying UL approval affixed in a conspicuous location on the socket body. Sockets shall be ringless unless combined with a disconnect. Sockets shall be supplied with four pressure type jaws designed for full contact with both sides of the meter blades and provisions for a fifth terminal in the 9 o'clock position. (Fifth terminal only required for single phase 120/208V service)
- Meter sockets with a combined disconnect meeting these specifications are acceptable, and if ring type, socket shall have a stainless steel (screw or clip type) or aluminum screw type sealing ring. Aluminum clip type sealing rings **are not** acceptable.
- 100 Amp single-phase sockets (for temporary use) require #6 - 2/0 lay-in pressure type line terminals and shall be rated for 100A continuous use.
- 200 Amp single-phase sockets require #1 - 250MCM lay-in pressure type line terminals and shall be rated for 200A continuous use.

- 200 Amp single-phase 2 - gang sockets require 1/0 thru 350MCM lay-in pressure type line terminals with a main bus rated at 200 amps continuous with #6 - 250MCM lay-in pressure type load terminals.
- 200 Amp single-phase 4-gang sockets require 3/0 thru 400MCM lay-in pressure type line terminals with a main bus rated at 360 amps continuous with #6 - 250MCM lay-in pressure type load terminals.
- 200 Amp single-phase 6-gang sockets require 3/0 through 500MCM lay-in pressure type line terminals with a main bus rated at 528 amps continuous with #6 - 250MCM lay-in pressure type load terminals.
- 200 Amp three-phase sockets require 7 terminal, three-phase lever bypass switch, #1 - 350MCM lay-in pressure type line terminals and 4/0 - #1 neutral two gang terminal as well as a bonding terminal to accept #2 wire. A Landis & Gyr HQ-7 #64558-1 block or Millbank interior #911500 including insulating shield is required. This socket shall be rated at 160 amps for continuous use.
- 400 Amp single-phase sockets require 4 terminal, single-phase lever bypass switch, line terminals to have 3/8" cold-headed zinc-plated steel studs with nuts and captive Belleville washers to accommodate various type lugs to 600MCM. Included with the meter shall be two sets of three each mechanical twin lug assemblies to accept line conductor sizes to 350MCM. A Landis & Gyr HQ-4S block or Millbank interior #911702, including insulating shield, is also required. This socket shall be rated for 320A continuous use.
- 400 Amp three-phase sockets require 7 terminal, three-phase lever bypass switch, line terminals to have cold-headed zinc-plated steel studs with nuts and captive Belleville washers to accommodate various type lugs to 600MCM. A Landis & Gyr block or Millbank interior including insulating shield is required. This socket shall be rated for 320A continuous use.
- Meter sockets used in underground applications shall be in accordance with JEA Rules and Regulations, Figure 7.02, Self-Contained Meter Socket – UG Service – 1 Phase 3 Wire 120/240V – Service Size: 200 Amp Maximum. Knockout(s) for three-inch underground conduit are required.
- Meter sockets where service neutral conductor is required to be isolated by code and the meter type installed requires a neutral connection, an isolated lug with additional neutral lead tap must be provided for the meter return

Items purchased from an electrical supply house must meet the previous specifications.

7.05 POINT OF METERING

The point of metering for a service is the point on the customer's service entrance where either a self-contained meter or JEA instrument transformers are located. The point of metering for **ALL SERVICES** shall be ahead of the customer's service equipment.

EXCEPTION: Where an unmetred main is required ahead of multi-metered services. Reference Section 2.23, Security of Service Equipment Ahead of JEA Point of Metering.

7.06 METERING EQUIPMENT CABINET SEALING/LOCKING REQUIREMENTS

That portion of the customer service entrance that is ahead of the JEA point of metering shall be placed under the security of seals and/or locks installed by Customer Field and Meter Services as stated in Sections 2.22, Security of Service Entrance and 2.23, Security of Service Equipment Ahead of JEA Point of Metering.

In addition, the customer shall provide for the secure installation of JEA metering equipment. Instrument transformers installed in cabinets or switchgear metering cubicles shall be secured against unauthorized access. Removable cover and/or doors allowing access into the instrument transformers shall be equipped with a means to allow the installation of seals and/or locks by JEA. The customer shall provide a means of attaching seals and/or locks that is acceptable to Customer Field and Meter Services.

7.07 PRIMARY SERVICE INSTRUMENT TRANSFORMER INSTALLATION

The installation of instrument transformers is an integral part of the installation of the primary service. Therefore, specific customer and JEA responsibilities regarding the installation and location of instrument transformers, enclosures, metering equipment, etc. are presented in Chapter VI, Primary Metered Services. In addition, the primary meter installation shall comply with the requirements of this chapter.

Instrument transformers installed by the customer shall be permanently mounted and their bases solidly grounded.

7.08 SECONDARY SERVICE CURRENT TRANSFORMER INSTALLATION AT WEATHERHEAD

Current transformers installed outdoors shall be located ahead of the customer's weatherhead. For single-phase services refer to Figure 7.07, Current Transformer (Wall Mounted) – Existing OH Service 1 Phase 120/240V – Service Size: Above 400 Amps, 800 Amp Maximum; for three-phase services refer to Figures 7.06, Current Transformer (Wall Mounted) – Existing OH Service – 3 Phase All Voltages – Service Size: Above 400 Amps, 800 Amp Maximum and 7.06A, Current Transformer (Horizontal Mast Mounted) – Existing OH Service – 3 Phase All Voltages – Service Size: Above 400 Amps, 800 Amp Maximum. The CTs shall be securely mounted on a metal bracket (galvanized steel or aluminum) with each CT solidly grounded. The metal mounting bracket shall be permanently attached to either the building wall or the service entrance mast. Potential leads to the metering equipment shall be provided by JEA from the splices at the point of connection.

7.09 SECONDARY SERVICE CURRENT TRANSFORMER INSTALLATION IN CABINETS

Current transformers not installed outdoors ahead of the customer's weatherhead shall be installed in a cabinet which shall be acceptable to Customer Field and Meter Services. The cabinet shall be provided with a means of installing seals and/or locks as required by Section 7.06, Metering Equipment Cabinet Sealing/Locking Requirements. Reference Figure 7.08, Current Transformer (Cabinet Mounted) – UG Service – 1 Phase & 3 Phase All Voltages – Service Size: Above 400 Amps. The cabinet shall be mounted on an outside wall, either inside or outside of the residence/building. The cabinet shall be mounted a minimum of 6 inches and a maximum of 6 feet above the finished grade. Large cabinets (3 feet square or larger) shall be equipped with hinged doors. No customer wiring or equipment shall be allowed in the CT cabinet except the customer's service entrance. The installation of CTs in the wireway of the customer's service equipment shall not be allowed.

CTs shall be securely mounted within the cabinet. The secondary terminal compartment of each CT shall be readily accessible and the nameplate data of each CT shall be visible without disturbing the customer's service entrance. The cabinet shall be grounded in accordance with the NEC and the local inspection authority requirements.

When CTs are installed on a cable type service entrance, the customer shall provide UL listed and CSA Certified for 600 Volts insulation piercing connectors (such as "Utilco Kupler" # UPC500-12" or equivalent) for each phase and a neutral for JEA connection of #12 AWG solid copper potential leads.

The customer shall mark the service entrance conduits entering the CT cabinet "LINE" for conduits from JEA source side and "LOAD" for conduits to the customer service equipment.

7.10 RACEWAYS FOR INSTRUMENT TRANSFORMER SECONDARIES

The customer shall provide a raceway from the instrument transformer cabinet to the meter enclosure.

The raceways shall be 1½ inch or larger SCH 40 PVC (UV rated gray electrical). Conduit must be effectively bonded to meter socket/enclosure. Electrical SCH 80 PVC (UV rated gray electrical) is required where exposed to physical damage. The raceway shall be used solely for the installation of instrument transformer secondaries. The raceway shall not exceed 125 feet in length from the instrument transformer terminals to the meter test block terminals. This distance is reduced to 25 feet when the CTs installed in padmounted transformer. All raceways must have a pull wire in them strong enough to pull eight #12 AWG solid copper wire and one #10 AWG stranded wire. A bond, connected from the customer's single point bonding system, must be supplied by the contractor at the CT location on overhead and underground services. All bonding must be done in accordance with the National Electrical Code and local inspection authority requirements.

On outdoor installations with instrument transformers mounted at the weatherhead, the raceway must extend 6 inches above the top of the highest transformer.

Raceways having the equivalent of four 90 degree bends or offsets or a total of 360 degrees shall be provided with exposed pull boxes. The pull box shall be minimum size 6" x 6" x 4" deep. The pull box shall be located such that it is easily accessible for maintenance and that an equal number of 90 degree bends or offsets will be on either side of the box. Junction boxes shall be provided with a means of installing seals and/or locks as required by Section 5.05, Customer Service Equipment. Pull boxes shall be sealed by JEA Commercial Meter Services.

7.11 RACEWAY FOR REMOTE INTERROGATION PHONE LINE

JEA requires that a dedicated 1/2" or larger conduit be installed between the metering point and the customer's telephone room for metered secondary service (2,000 amps or greater, 120/208V; 1,000 amps or greater, 277/480V) and all primary meter services. The raceway shall be of EMT for the interior of the structure and of SCH 40 PVC (UV rated gray electrical) from the exterior wall of the structure to the meter enclosure. The installation of a pull wire is required.

7.12 LOCATION OF METERS

Meter locations shall be approved by Customer Field and Meter Services (self-contained services – Field Meter Services, CT services – Electric Meter Services). Customers shall be required to pay for damages to and replacement cost of all metering equipment resulting from accidents to meters located in unauthorized locations.

Meters shall be mounted at centerline maximum 6'-0" and minimum 4'-0" above finished grade.

Exceptions:

- Prewired Meter Centers: as noted in Figure 7.12, Prewired Meter Center Installation – UG & Existing OH Service.
- Irrigation, lighting, sign commercial services (limited to single-phase \leq 200 amps) where the wall height would prohibit 4' minimum to the centerline of the meter. The minimum may be reduced to 3' above finished grade to the centerline of the meter. This is not applicable to residential services. Irrigation, lighting, sign services located within residential developments that are for the community and/or associations are considered commercial services.

Meters shall be installed outdoors and shall be readily accessible to JEA at all times. If the meter becomes inaccessible to JEA due to locked fences, building conditions, animals or any other reason; the customer shall be required to relocate the meter or perform other changes necessary to make the meter accessible to JEA.

When a meter socket is recessed in a wall, it shall be recessed to allow the lid to be easily removed and seals and/or locks easily installed. When a meter enclosure is recessed in a wall it

shall be recessed in accordance with Figure 7.13, Recessed Meter Socket/Enclosure Installation.

A safe working space around meter socket(s)/enclosure(s) must remain free of all obstruction. The space required will be 2 feet on each side and 4 feet in front.

Meters and metering equipment installed on the driveway or parking lot side of a commercial service shall have a 4 foot lateral clearance from the meter to the parking or driving surface unless the meter and equipment are protected by a permanent part of the building/structure or guard structures. Guard structures shall consist of 6 inch diameter by 8 foot long galvanized steel or black iron pipe mounted in and filled with concrete. The pipe shall be mounted 4 feet below grade with 4 feet extending above grade. The above grade portion shall be painted DOT yellow. Reference Figure 4.03C, Bollard Detail.

Upon customer request, Customer Field and Meter Services (self-contained services – Field Meter Services, CT services – Electric Meter Services) may permit the use of meter rooms in multi-occupancy buildings of three stories or more in height. Prior to beginning construction, the customer shall provide Customer Field and Meter Services with two copies of plans for approval. If the meters are installed in a meter room, provision for communication must be made as directed by Customer Field and Meter Services. Meters shall not be installed without approval of Meter Services Operations and Maintenance. Meter rooms shall not be allowed in any location other than multi-occupancy buildings of three stories or more in height.

Meter rooms shall be well lighted and shall be used exclusively for the housing of JEA metering equipment and the customer's service equipment. Meter rooms shall not be used for storage or any other purpose. The customer must install a lockbox, in a non-secured JEA-accessible location, that contains a key to the meter room. Lockbox shall be a 4-digit combination type, similar in size and function to Master Lock Safe Space. JEA shall administer the combination to the lockbox.

7.13 IDENTIFICATION OF METERS

Each facility served by JEA shall have the street address posted as required by Section 2.20, Posting of Address. In addition, where meters are installed in groups, such as for multi-occupancy buildings, mobile home services, etc., each meter socket or enclosure shall be permanently identified with the assigned street address and/or apartment number so that JEA can associate the meter with the customer served.

Each occupancy shall have its unique address permanently posted adjacent to the entrance of the occupancy. Since doors are often relocated from one occupancy to another, JEA does not consider a door to be a permanent location for posting the address.

The meter socket or enclosure shall have the address or apartment number painted on the inside and outside with a black, oil base enamel. Surfaces to be painted shall be properly cleaned before painting. Alternate methods of permanently identifying meter sockets or enclosures

shall be approved by Customer Field and Meter Services (self-contained services – Field Meter Services, CT services – Electric Meter Services) prior to installation.

7.14 REQUIRED METERING INSTALLATION UPGRADES

When an existing single family residential customer (one metering system) increases the service size or replaces the line and load conductors, the service shall be brought into accordance with these Rules and Regulations for Electric Service.

When an existing service having two metering systems increases the service size, the customer's metering installation shall be brought into accordance with the requirements of these Rules and Regulations. Reference Section 2.08, Combination of 240V Delta and 120/240V Single-Phase Services. When any existing CT service (single-phase or three-phase) up to 400 Amps ALL VOLTAGES is modified and that modification includes the replacement of the service entrance on the line side of the JEA point of metering, the customer shall be required to install a self-contained meter socket.

At a minimum, the customer shall be required to:

- Relocate meters located inside a building or an inaccessible area to an accessible area outdoors.
- Replace self-contained A-Base meters with socket type meters.

Reference Section 7.12, Location of Meters.

7.15 METER IMPULSE SIGNALS TO CUSTOMER

JEA Electric Meter Services shall, upon customer request, install impulse generation equipment at the JEA meter location. The data provided to the customer by JEA is for the explicit purpose of load monitoring and load control.

The customer shall provide all wiring and all translation, monitoring, and control equipment beyond the JEA meter location. The customer shall be required to provide contribution-in-aid-of-construction for any JEA metering equipment installed beyond that normally provided for the customer's class of service. The customer shall contact JEA Electric Meter Services for complete information concerning this subject. Reference Figure 4.03D

7.16 METER TESTS AND ADJUSTMENTS FOR FAILED METER

JEA makes every effort practical to maintain the standard accuracy of the JEA metering installation. If, upon test, any metering equipment is found to be in error by not more than 2%, previous recordings of the metering equipment shall be considered accurate. These shall be used by JEA in computing the customer's billing for service under the applicable rate schedule.

If upon test, any metering equipment is found to be in error by more than 2%, all previous recordings by such equipment shall be corrected for the error for a period not to exceed 12 months or as defined by JEA policy.

Customer requests for meter tests and information concerning billing adjustments shall be made through JEA Customer Experience Center. If a customer requests a meter be tested and the test shows the metering equipment to be within acceptable accuracy limits, a charge shall be assessed against the customer. Charges and billing adjustments shall be made in accordance with the latest JEA policy.

7.17 JEA APPROVAL OF CUSTOMER FURNISHED METER CENTER

The customer may elect to provide prewired meter centers as shown in Figure 7.12, Prewired Meter Center Installation – UG & Existing OH Service. Meter centers provided by the customer shall be approved by JEA Field Meter Services prior to installation by the customer. The customer shall be responsible for all maintenance, including parts and labor, of prewired meter centers.

(This page left blank.)

Chapter VIII Customer Utilization Equipment

(This page left blank.)

8.01 GENERAL

JEA builds and maintains an electrical system to provide high quality and reliable electric service to all customers. However, since electrical equipment operated by one customer may adversely affect the quality and continuity of service to another customer and since the misuse of some equipment may constitute a fire hazard or endanger life, this chapter establishes guidelines and requirements governing the installation and operation of some of the more common types of customer utilization equipment. The customer should contact JEA System Analysis for additional information or for information on equipment not covered within this chapter. The characteristics of the customer's electrical load shall be such that the load balance, voltage fluctuation, power factor, generation of harmonics, or any other factor does not adversely affect the operation of the JEA system or the quality of service to other JEA customers. JEA may require that the customer provide contribution-in-aid-of-construction for JEA to correct the problem if no action is taken by the customer within a reasonable time period. Extreme cases may require disconnection of customer service while corrective action is taken. Contact JEA System Analysis.

8.02 VOLTAGE FLUCTUATION LIMITS

Maximum allowable voltage fluctuations are shown by Figure 8.01, Maximum Allowable Voltage Fluctuations. Voltage fluctuation limits for welder operation, motor starts and/or any customer operations that result in rapid changes in either generation or load are shown in the following table. Examples of customer owned equipment that can initiate these voltage fluctuations are provided below in Table 8A. The generation of voltage fluctuations in excess of these limits may require JEA to disconnect the customer's service until corrective action is taken by the customer.

Voltage fluctuations are evaluated at either of two points. In the case of customer complaints, voltage fluctuations are evaluated at the point of JEA service to the customer with the complaint. In the case a customer requesting permission to operate equipment, the voltage fluctuation is evaluated at the point on the JEA system where the quality of service to other customers may be affected.

Table 8A
VOLTAGE FLUCTUATION LIMITS

MAXIMUM FLUCTUATION	EQUIPMENT	OPERATING RESTRICTIONS
½%	Welders	None
1%	Motors	Unlimited times per day
2%	Motors	Maximum 2 times per day
5%	Motors	Once per day between 1 a.m. and 6 a.m.
Above 5%	All	Not allowed

8.03 MOTOR STARTING

Since JEA offers a wide variety of customer service voltages and configurations, no specific limit on the maximum size motor that can be started across the lines has been established. However, based on general standards of design, across the line starting of any motor in excess of the following horsepower, voltage and phase ratings shall require written approval from JEA System Analysis.

**Table 8B
ACROSS THE LINE MOTOR STARTING LIMITS**

TRANSFORMER SERVING MULTIPLE CUSTOMERS	
Single phase, line to neutral operation	2 horsepower
Single phase, line to line operation	4 horsepower
Three phase operation	5 horsepower
SECONDARY NETWORK SERVICES	
Three phase operation	30 horsepower
PRIMARY SERVICE & SINGLE CUSTOMER TRANSFORMER SERVICES	
Three phase operation	50 horsepower

JEA recommends that customers with three phase service not utilize single phase motors operating on line to neutral voltages larger than 1 horsepower or line to line voltages larger than 2 horsepower.

8.04 PROTECTION OF MOTORS AND OTHER EQUIPMENT

The customer is responsible for protecting motors and other equipment against under voltage, over current, phase failure (single phasing), phase reversal, power interruptions and short circuits.

Motors which cannot be safely subjected to full voltage starting and processes which may create a safety hazard upon uncontrolled re-start, should automatically assume a stop or off condition upon the interruption of the supply voltage.

8.05 EQUIPMENT VOLTAGE RATING

JEA cautions the customer against using equipment with a nameplate voltage rating that is inappropriate for the standard system voltage provided by JEA. Deviations of plus or minus 5% of nominal rated service voltage are not uncommon in a utility distribution system and an additional voltage drop of 10% may occur on the customer's internal wiring system. While equipment is generally designed by the manufacturer to operate at nameplate voltage plus or

minus 10%, the operation of equipment with an inappropriate nameplate voltage for the service voltage supplied may result in damage to the equipment.

For example, if a 230V, three phase motor is used on a 120/208V system, the motor could experience voltages as low as 178V or 14% below the motor's minimum operating voltage.

MINIMUM MOTOR OPERATING VOLTAGE = 230V - 10% = 207V
MINIMUM UTILITY VOLTAGE = 208V - 5% = 197.6V
MINIMUM CUSTOMER VOLTAGE = 197.6V - 10% = 177.8V

8.06 ARC WELDERS

Arc welders of the transformer type usually have such severe load characteristics that voltage dip and lighting flicker may result during their operation. Welders of this type can be detrimental to the service being rendered to other customers, especially when served directly from JEA's secondary lines. It is the customer's responsibility to provide the necessary power conditioning and power factor correction equipment to prevent this type of load from affecting the JEA system. JEA may require that the customer provide contribution-in-aid-of-construction for JEA to correct the problem if no action is taken by the customer within a reasonable time period. Contact JEA System Analysis before the installation of such welders.

8.07 DC EQUIPMENT (OTHER THAN WELDERS)

Customers installing SCR, diode or other AC to DC converters are advised to install drive isolation transformers designed to help minimize equipment damage and to prevent noise and harmonics from being generated back onto the customer and JEA distribution systems. Where the desired DC voltage level is critical, consideration should be given in the selection of the equipment for voltage fluctuation normally existent in the AC supply. It shall be the responsibility of the customer to provide the required surge suppression and power conditioning equipment to protect this type of load from damage and to insure that it will operate within the constraints of the delivered JEA service voltage as specified in Section 2.12, Voltage Control.

8.08 FLASHING LIGHTS

All flashing signs or lights served by JEA shall be provided with such necessary switching and control equipment as may be needed to eliminate undesirable flicker and radio and television interference to other customers.

8.09 X-RAY MACHINES, BROADCASTING EQUIPMENT, AND ARC FURNACES

Due to the very severe operating characteristics of such equipment as furnaces, x-ray, radio and television broadcasting stations, the customer shall consult with JEA System Analysis before installation is made.

8.10 COMPUTERS AND SENSITIVE ELECTRONIC EQUIPMENT

JEA makes every effort to provide reliable and high quality electric service to the customer, but due to the relatively slow action of the electro-mechanical relays used for voltage control and overcurrent protection and the operation of noise generating equipment by the customer, voltage fluctuations and instantaneous interruptions may exist that adversely affect the operation of computers and other sensitive electronic equipment. Before installing any sensitive electronic equipment the customer is advised to have the equipment manufacturer monitor the voltage of the supply system to the equipment in order to determine the power adequacy and recommend any power conditioning equipment that may be necessary. It is the customer's responsibility to install the required surge suppression and power conditioning equipment to protect this type of sensitive electronic load from damage, and to ensure that it will operate within the constraints of the JEA service voltage as defined in Section 2.12, Voltage Control. Contact JEA System Analysis if there are any questions concerning the quality of JEA power.

8.11 HARMONICS

Harmonics result from non-linear loads such as electronic switching power supplies and power converters. Harmonics are measured with respect to the fundamental frequency (60 Hz) of the US power system and classified by order as a function of the fundamental frequency.

Harmonics in general can adversely impact the electric power system and adjacent customers, but a few common orders of odd harmonics that can be found in power systems are the third (3rd), fifth (5th), seventh (7th) and ninth (9th).

A non-linear load is a load in which the load current is not proportional to the instantaneous load voltage. Non-linear loads are non-sinusoidal, and even when the source voltage is a clean sine wave, the non-linear loads will distort that voltage waveform, making it non-sinusoidal. Typical non-linear loads are electronic switching power supplies and other power electronics such as used in adjustable speed drives, solar photovoltaic and battery storage inverters, and electronic ballast. Certain loads and power converters can generate harmonics due to the non-linear manner in which they draw or generate current. This results in harmonic distortion that is injected into the JEA Electrical Distribution System. High levels of voltage or current harmonics may cause the disruption or failure of customer equipment or JEA distribution equipment. It is the customer's responsibility to limit the amount of harmonics that are introduced into the JEA system due to the non-linear loads or generation equipment at the customer's site.

JEA Rules & Regulations For Electric Service
Chapter VIII Customer Utilization Equipment

JEA requires that customers comply with the latest published version of the IEEE 519 Standard. JEA reserves the right to measure the amount of harmonics at any time and to conduct any long term monitoring required to determine the effect of these harmonics on the JEA system. The customer is responsible for the design, installation, operation, and maintenance of customer owned harmonics mitigation equipment required to meet JEA's harmonic limits.

Notable examples from the 2014 IEEE 519:

Voltage Distortion Limits:

- For customers receiving service at 1000 volts (V) or less, no individual harmonic shall exceed 5% and the total Harmonic Distortion shall not exceed 8%
- For customers receiving primary service at 69 kilovolts (kV) or less, no individual harmonic shall exceed 3% and the total Harmonic Distortion shall not exceed 5%

Current Distortion Limits:

- For customers with power generation equipment, including solar photovoltaic or battery storage inverters, individual odd harmonics shall not exceed predetermined limits as listed in IEEE 519.

Contact JEA System Analysis with any questions.

(This page left blank.)

Appendix A

Electric Service Area Contacts

(This page left blank.)

JEA Rules & Regulations For Electric Service
Appendix A Electric Service Area Contacts

JEA ELECTRIC SERVICE AREA CONTACTS

JEA Electric Services designates/approves the service location for each electrical service provided and each existing electrical service where the service entrance is being modified. (Reference 2.06 Service Location requirements). US Postal zip codes define responsible service engineer assignments.

Zone - WS-NORTH-EAST William Conway Phone: 904-776-0845 Email: conwwt@jea.com 32202, 32206, 32226, 32209	Zone - SS-WEST-SOUTH Brian Midkiff Phone: 904-562-8300 Email: midkbm@jea.com 32207, 32217, 32223, 32257, 32258, 32259
Zone - WS-MID-CENTRAL TBD Phone: 904-000-0000 Email: x@jea.com 32200	Zone - SS-MID-EAST Morgan D'Amico Phone: 904-568-4238 Email: worlmf@jea.com 32081, 32216, 32224, 32246, 32256
Zone - WS-WEST Billie Woods Phone: 904-627-6310 Email: woodbj@jea.com 32220, 32221, 32222, 32234, 32205	Zone - SS-NORTH-EAST Robert Simpson Phone: 904-568-8266 Email: simprb@jea.com 32211, 32225, 32233, 32250, 32277
Zone - WS-MID-SOUTH Eric Theodoridis Phone: 904-562-8461 Email: theoej@jea.com 32073, 32210, 32244, 32204	Large Commercial Services Costa Theodoridis Phone: 904-591-4171 Email: theoc@jea.com Lloyd Lesley Phone: 904-652-5952 Email: leslla@jea.com Esau Larios Phone: 904-870-1570 Email: larie@jea.com
Zone - WS-NORTH-WEST Marc Nelson Phone: 904-759-8303 Email: nelsjm@jea.com 32208, 32218, 32219, 32254	
Large Commercial Service Submit Plans: https://jeacomelectric.powerclerk.com/ For General Questions on services greater than 600 amps email: elecdev@jea.com	

JEA Rules & Regulations For Electric Service
Appendix A Electric Service Area Contacts

JEA ELECTRIC SERVICE AREA BOUNDARY MAP

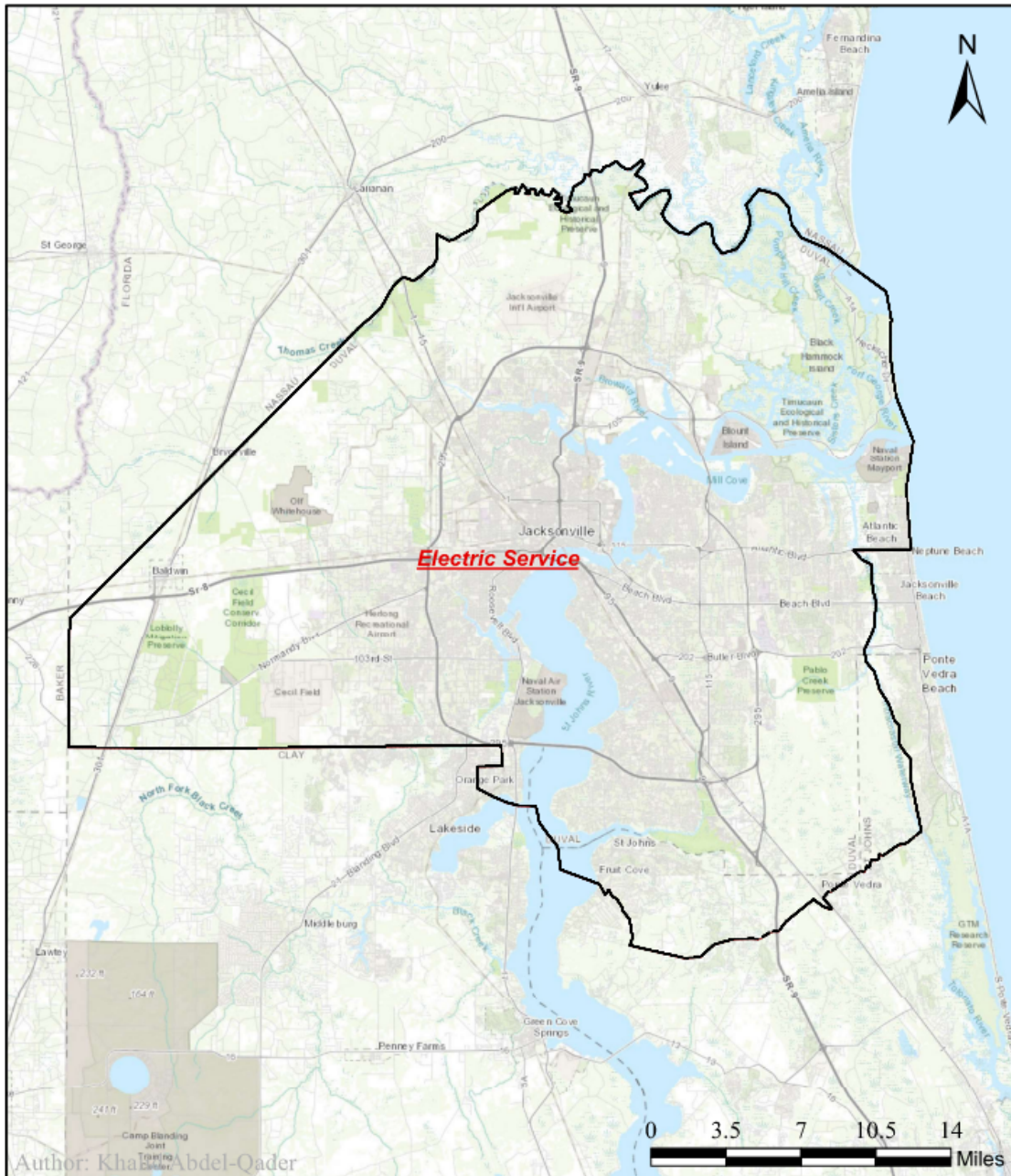

For underground residential service locate map requests (within planned UG developments)

<https://www.sagesgov.com/jea-fl>

For area lighting requests on existing JEA poles contact the business office at 904-665-6000

For COJ public roadway street light requests: myjax.custhelp.com [Streetlights \(custhelp.com\)](http://Streetlights.custhelp.com)

Appendix B

Figures

(This page left blank.)

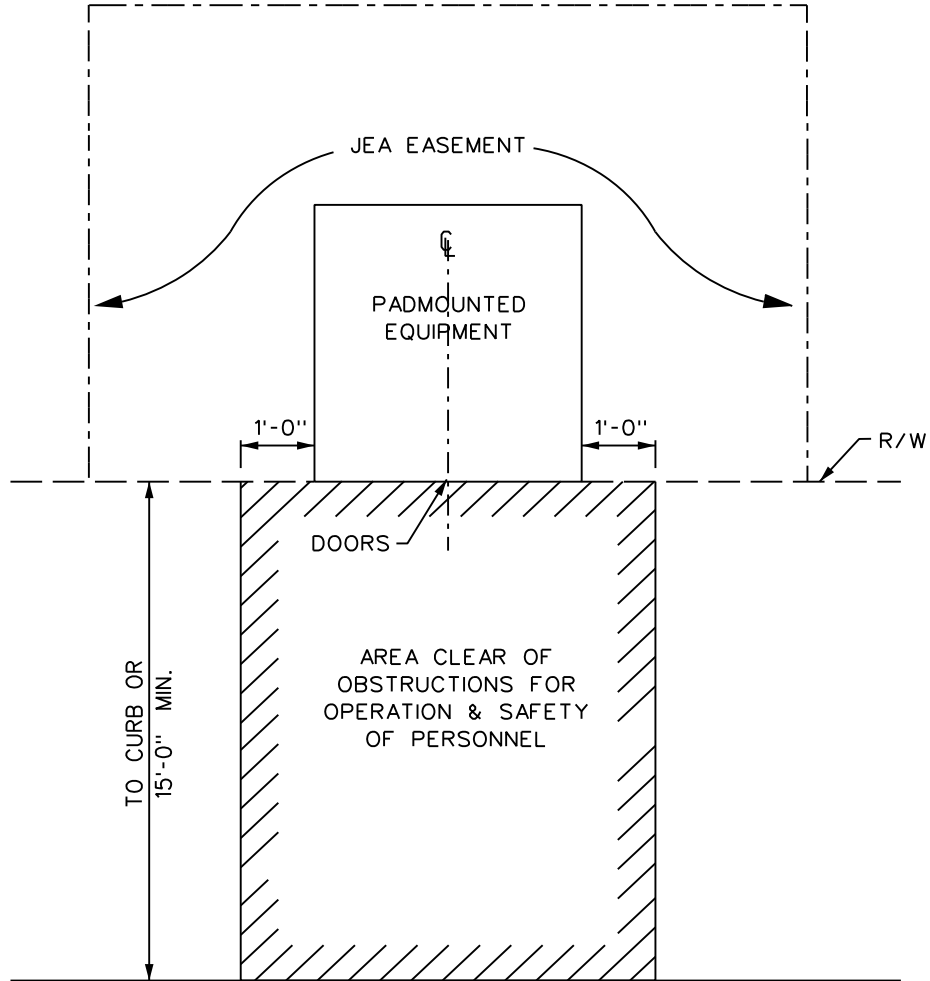

NOTE: REFERENCE SECTION 1.08 - PROTECTION BY CUSTOMER OF JEA PROPERTY.

APP'D:	DRN: WILSON	PADMOUNTED AREA CLEARANCE FROM OBSTRUCTIONS	
DATE :11-20-92 10-12-95 10-24-96 11-4-96 4-2-99 9-6-01	SCALE: NONE		

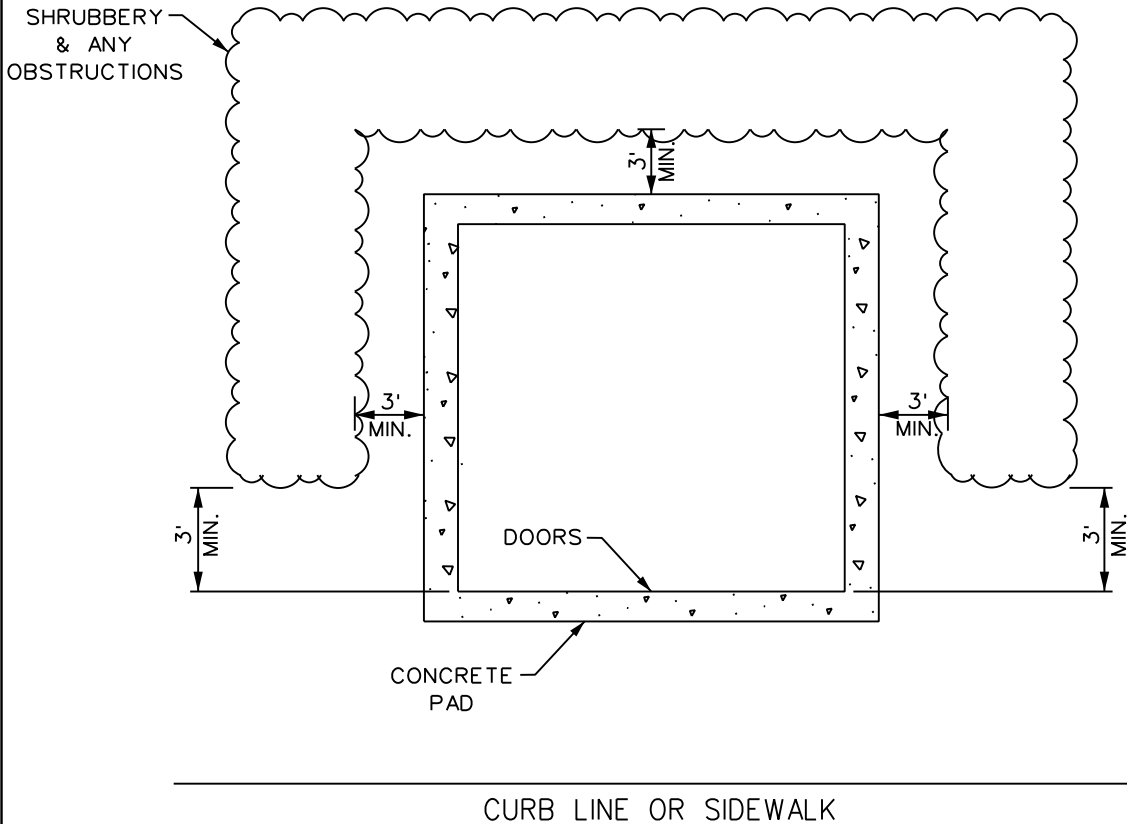

CLEARANCE NEEDED FOR PROPER OPERATION OF
EQUIPMENT & SAFETY OF PERSONNEL.

ACCEPTABLE SHRUBBERY	UNACCEPTABLE SHRUBBERY
LIGUSTRUM SPP.	PAMPAS GRASS
PODOCARPUS SPP.	SPANISH BAYONET
BOXWOOD	WISTERIA (OR ANY CREEPER)
AZALEA	PYRACANTHA
CAROLINA LAUREL CHERRY	ORLEANDER
VIBURNUM SPP.	
JAPANESE YEW	

NOTE: REFERENCE SECTION 1.08 - PROTECTION BY CUSTOMER OF JEA PROPERTY.

APP'D:	DRN: WILSON	SHRUBBERY PLANTING SPECIFICATIONS PADMOUNTED TRANSFORMERS	
DATE :11-20-92 10-12-95 10-24-96 11-4-96 4-2-99 4-10-00	9-6-01		
SCALE: NONE		JEA RULES AND REGULATIONS JACKSONVILLE , FLORIDA	FIGURE: 1.02

JEA SERVICE LOAD CALCULATION

PROJECT: _____

SERVICE ADDRESS: _____

PERMIT NUMBER: _____

ELECTRICIAN: _____ **PHONE:** _____

SIGNATURE: _____ **LICENSE NO.:** _____

ARCHITECT, MASTER ELECTRICIAN,
OR REGISTERED PROFESSIONAL ENGINEER

SERVICE INFORMATION

Voltage: _____	Amperes: _____	Phase (1 or 3): _____	Wire Size: _____	
Commercial: _____	Residential: _____	Overhead: _____	Underground up Pole: _____	Underground: _____
Sq. Ft. of Bldg: _____	Total HVAC Tons: _____	Number of Meters: _____	Existing Meter(s) # if applicable: _____	

LOAD DATA: (Description/Wattage/Specify 1ph or 3ph)
(Attach additional sheets, if required.)

COMMENTS:

Figure 2.01

OH SERVICE NOT AVAILABLE FOR NEW PERMANENT SERVICES

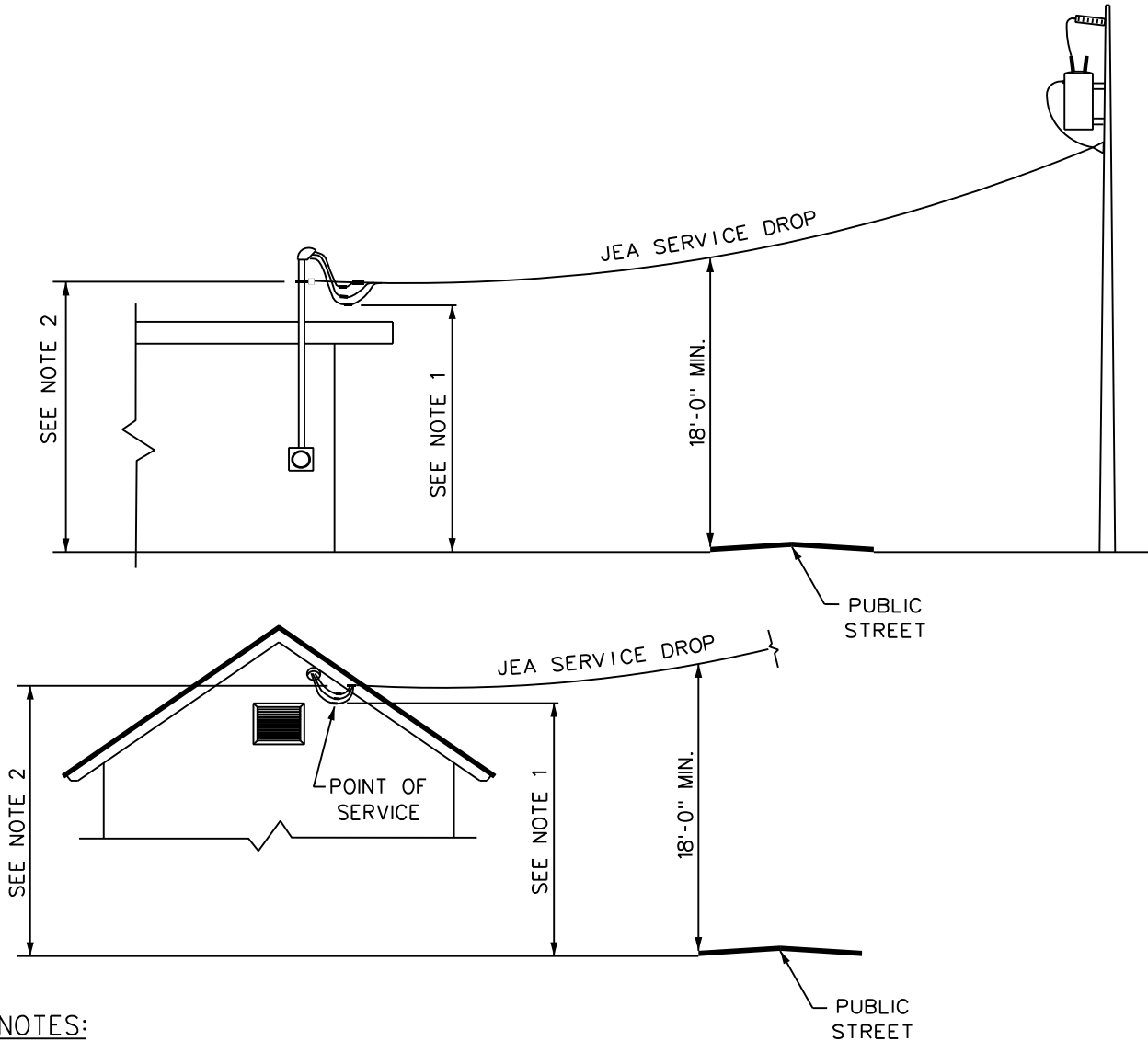

NOTES:

1. MINIMUM VERTICAL CLEARANCE OF CONDUCTORS: REFERENCE TABLE 3A AND SECTION 3.03.
2. MINIMUM POINT OF ATTACHMENT: REFERENCE TABLE 3A.
3. SERVICES 200 AMPS OR LESS: JEA MAY INSTALL A CLEARANCE POLE ON THE CUSTOMER'S PROPERTY WHEN THE LENGTH OF THE SERVICE DROP EXCEEDS 150 FEET.
4. SERVICES GREATER THAN 200 AMPS: CONTACT JEA SERVICE ENGINEER.
5. THE POINT OF ATTACHMENT SHALL NOT EXCEED PAST THE PEAK OR HALFWAY BACK ON THE STRUCTURE. IF MORE THAN 20 FEET BEHIND THE FRONT OF THE STRUCTURE, CONTACT JEA SERVICE ENGINEER.

APP'D:	DRN: WILSON	SERVICE DROP CLEARANCES EXISTING OH SERVICE	
DATE :	11-12-92 10-12-95 10-24-96 4-2-99 9-6-01		
SCALE:	NONE	JEA RULES AND REGULATIONS JACKSONVILLE, FLORIDA	FIGURE: 3.01

OH SERVICE NOT AVAILABLE FOR NEW PERMANENT SERVICES

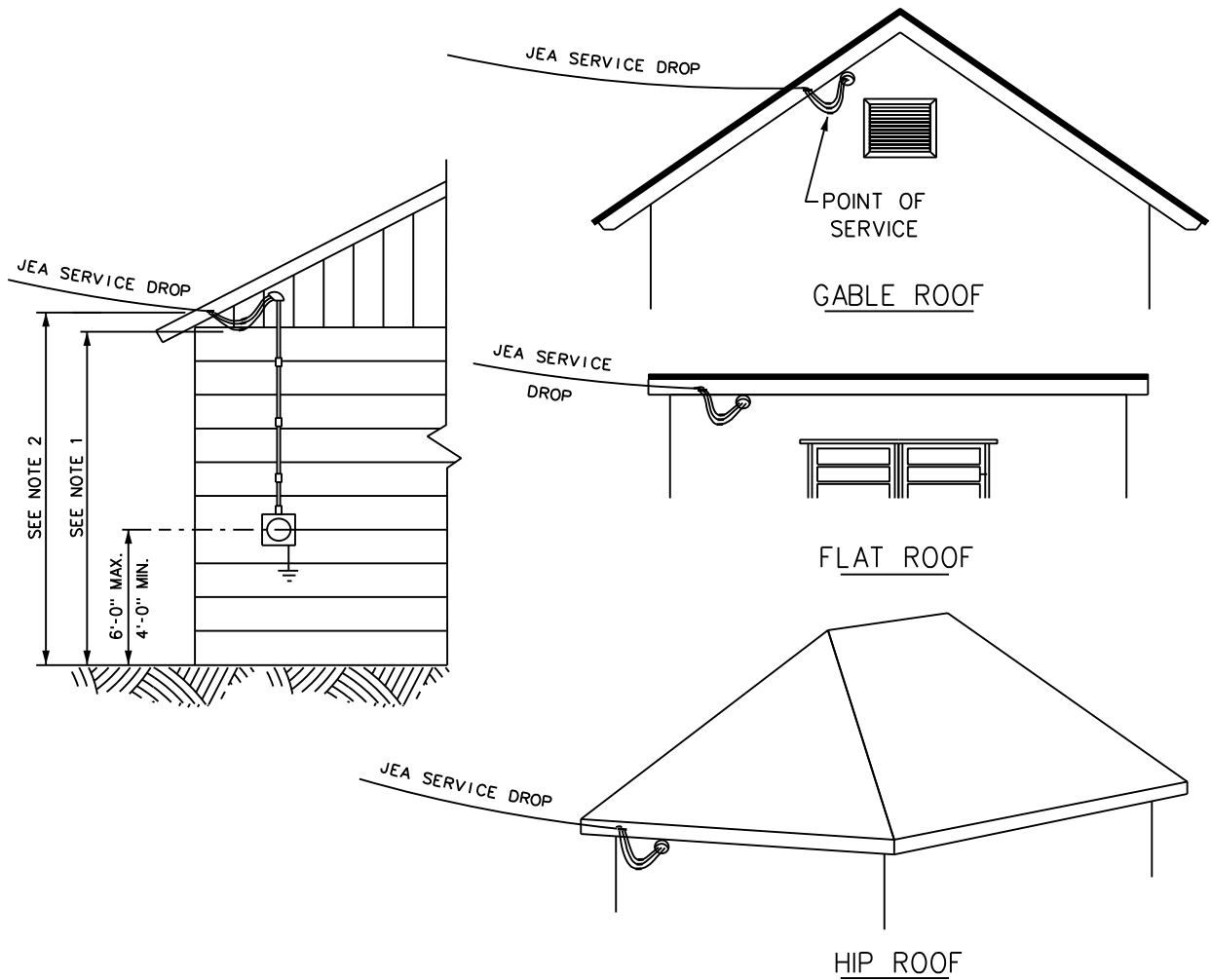

NOTES:

1. MINIMUM VERTICAL CLEARANCE OF CONDUCTORS: REFERENCE TABLE 3A AND SECTION 3.03.
2. MINIMUM POINT OF ATTACHMENT: REFERENCE TABLE 3A.
3. GROUNDING SHALL BE IN ACCORDANCE WITH THE NEC AND LOCAL INSPECTION AUTHORITY REQUIREMENTS.
4. WHERE EYEBOLT IN FASCIA IS USED, WEATHERHEAD SHOULD BE WITHIN 2' AND ABOVE EYEBOLT.
5. THE POINT OF ATTACHMENT SHALL NOT EXCEED PAST THE PEAK OR HALFWAY BACK ON THE STRUCTURE. IF MORE THAN 20 FEET BEHIND THE FRONT OF THE STRUCTURE, CONTACT JEA SERVICE ENGINEER.

APP'D:	DRN: WILSON	EYEBOLT SERVICE INSTALLATIONS EXISTING OH SERVICE	
DATE :	11-12-92 10-12-95 10-24-96 4-2-99 9-6-01		
SCALE:	NONE	JEA RULES AND REGULATIONS JACKSONVILLE , FLORIDA	FIGURE: 3.02

OH SERVICE NOT AVAILABLE FOR NEW PERMANENT SERVICES

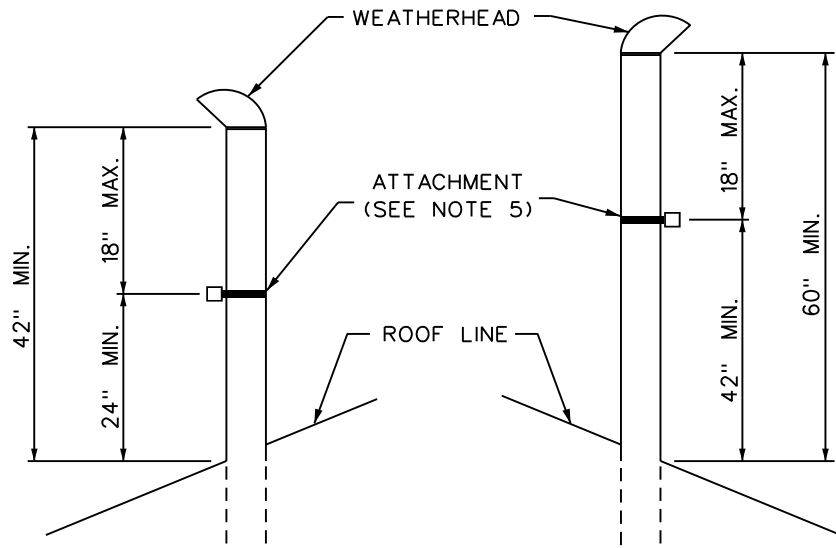

JEA SERVICE DROP CROSSING
6 FEET OR LESS, AND ATTACHMENT MUST
BE WITHIN 4 FEET OF EDGE OF ROOF

JEA SERVICE DROP CROSSING
MORE THAN 6 FEET AND/OR ATTACHMENT
MORE THAN 4 FEET FROM EDGE OF ROOF

18" MIN. VERTICAL
CLEARANCE ABOVE ROOF
(INCLUDING SERVICE DROP
AND DRIP LOOPS)

36" MIN. VERTICAL
CLEARANCE ABOVE ROOF
(INCLUDING SERVICE DROP
AND DRIP LOOPS)

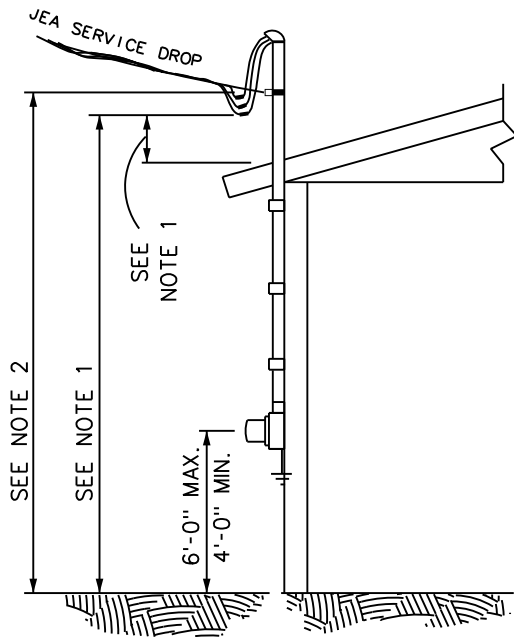

NOTES:

1. MINIMUM VERTICAL CLEARANCE OF CONDUCTORS: REFERENCE TABLE 3A AND SECTION 3.03.
2. MINIMUM POINT OF ATTACHMENT: REFERENCE TABLE 3A.
3. MINIMUM MAST RISER: SEE THE NEC AND LOCAL INSPECTION AUTHORITY REQUIREMENTS.
4. IF SERVICE DROP CROSSES MORE THAN 6 FEET OF ROOF, CONTACT JEA SERVICE ENGINEER.
5. IF THE DISTANCE BETWEEN ATTACHMENT AND WEATHERHEAD IS LESS THAN 6 INCHES, CONTACT JEA SERVICE ENGINEER.
6. SERVICES GREATER THAN 200 AMPS: CONTACT JEA SERVICE ENGINEER.
7. CT SERVICES: REFERENCE FIGURES 7.06A AND 7.07.
8. GROUNDING SHALL BE IN ACCORDANCE WITH THE NEC AND LOCAL INSPECTION AUTHORITY REQUIREMENTS.

APP'D: _____ DRN: WILSON

DATE : 11-12-92
10-12-95
10-24-96
4-2-99
1-18-04

MAST SERVICE INSTALLATIONS EXISTING OH SERVICE

SCALE:
NONE

JEA
RULES AND REGULATIONS
JACKSONVILLE, FLORIDA

FIGURE: 3.03

OH SERVICE NOT AVAILABLE FOR NEW PERMANENT SERVICES

PLAN VIEW

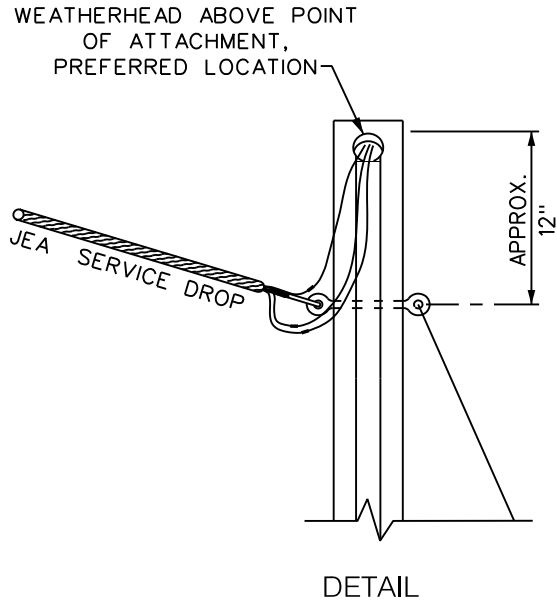
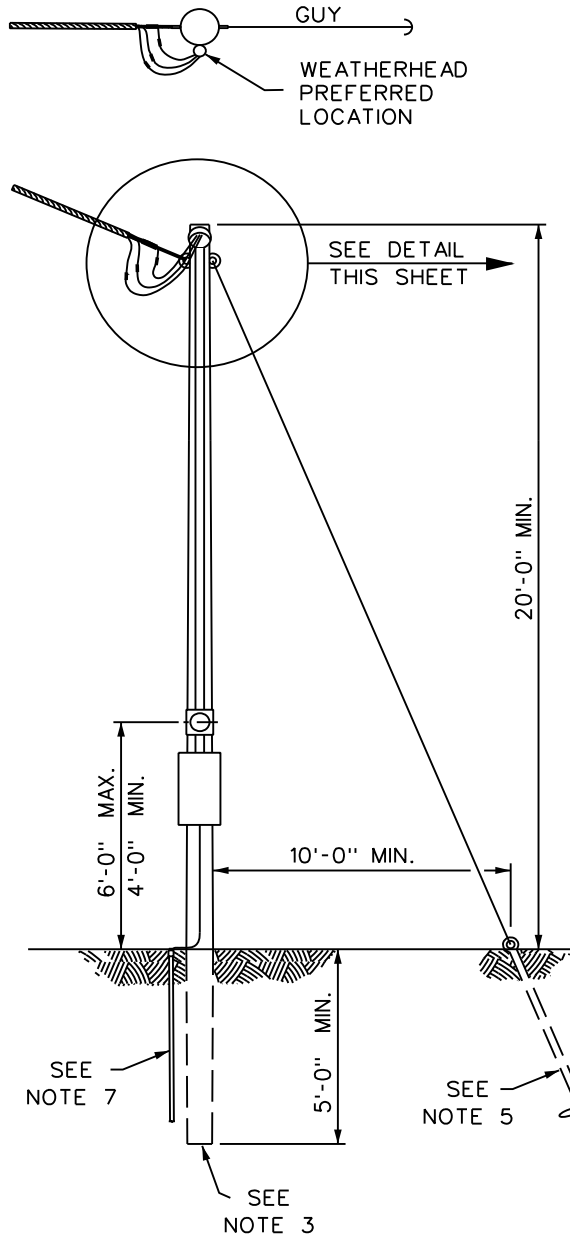

NOTES:

1. MINIMUM VERTICAL CLEARANCE OF CONDUCTORS: REFERENCE TABLE 3A AND SECTION 3.03.
2. MINIMUM POINT OF ATTACHMENT: REFERENCE TABLE 3A.
3. MINIMUM POLE REQUIREMENT: 25 FEET CLASS 7, PRESSURE TREATED WOOD.
4. IF SERVICE DROP CROSSES MORE THAN 6 FEET OF ROOF, CONTACT JEA SERVICE ENGINEER.
5. GUY AND ANCHOR NOT REQUIRED IF JEA SERVICE POLE IS ON SAME SIDE OF THE STREET AND WITHIN 50 FEET OF MOBILE HOME POLE/SERVICE POLE.
6. REFERENCE SECTION 3.04 FOR ADDITIONAL REQUIREMENTS.
7. GROUNDING SHALL BE IN ACCORDANCE WITH THE NEC AND LOCAL INSPECTION AUTHORITY REQUIREMENTS.

APP'D:	DRN: WILSON
DATE :	09-23-94 10-24-96 11-4-96 4-2-99

MOBILE HOME POLE/SERVICE POLE EXISTING OH SERVICE

SCALE:
NONE

JEA
RULES AND REGULATIONS
JACKSONVILLE, FLORIDA

FIGURE: 3.04

PLAN VIEW

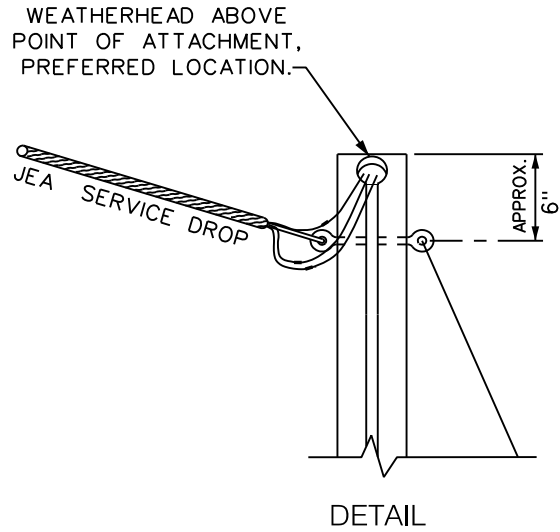
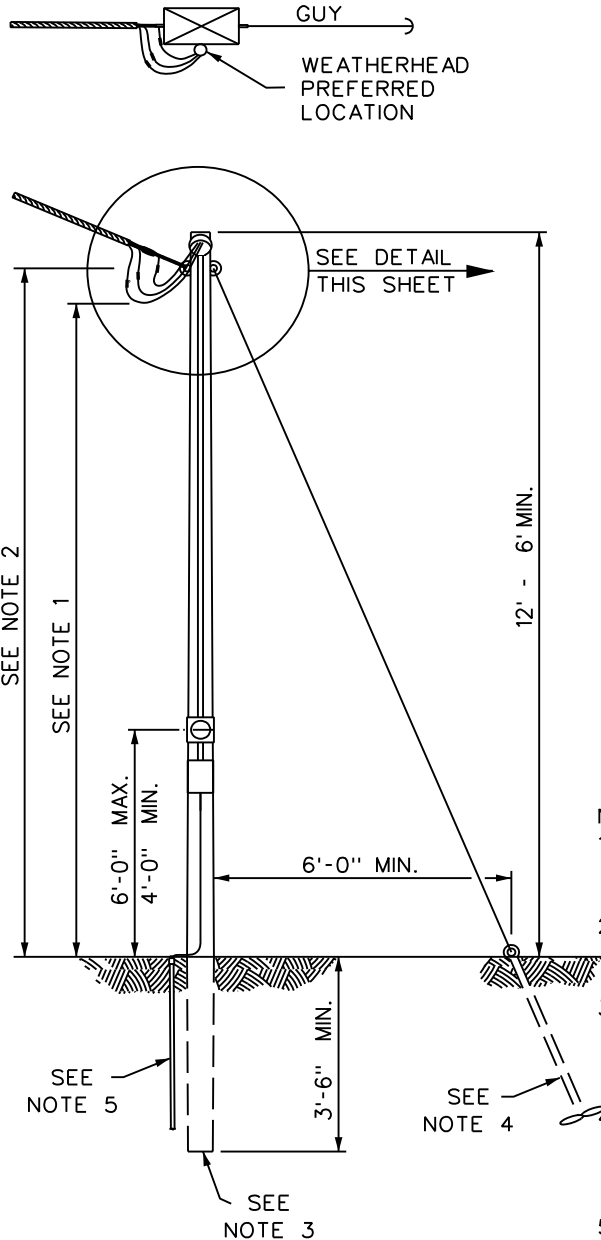

NOTES:

1. MINIMUM VERTICLE CLEARANCE OF CONDUCTORS: REFERENCE TABLE 3A AND SECTION 3.03.
2. MINIMUM POINT OF ATTACHMENT: REFERENCE TABLE 3A.
3. MINIMUM POLE REQUIREMENT: 4" X 6" X 16', PRESSURE TREATED WOOD. TALLER POLES: REFERENCE FIGURE 3.04.
4. GUY AND ACHOR NOT REQUIRED IF JEA SERVICE POLE IS ON SAME SIDE OF STREET AND WITHIN 50 FEET OF THE TEMPORARY POLE.
5. GROUNDING SHALL BE IN ACCORDANCE WITH THE NEC AND LOCAL INSPECTION AUTHORITY REQUIREMENTS.

BREAKER/DISCONNECT MAYBE USED IN PLACE OF METER CAN FOR QUALIFIED TPFRR SERVICES

APP'D:	DRN: WILSON
DATE :	11-12-92 10-24-96 11-4-96 4-2-99 08-08-2020

TEMPORARY POLE
OH SERVICE

SCALE:
NONE

JEA
RULES AND REGULATIONS
JACKSONVILLE , FLORIDA

FIGURE: 3.05

NOTES:

GENERAL:

1. 300 AMP MAX; FOR LARGER SERVICES CONTACT JEA SERVICE ENGINEER.
2. SERVICE MUST BE LOCATED ON SAME SIDE OF STRUCTURE AS CONDUIT STUB-OUT AND BE WITHIN 10' OF CORNER CLOSEST TO CONDUIT STUB-OUT. (FOR CONSTRUCTION CONFLICTS, CONTACT JEA SERVICE ENGINEER).
3. CONDUIT REQUIREMENTS:
 - A) 3 INCH MINIMUM
 - B) CHAMFERED EDGES
 - C) SCHEDULE 40 PVC; SCHEDULE 80 PVC REQUIRED IF EXPOSED TO DAMAGE
 - D) 36 INCH RADIUS MINIMUM FOR ALL ELBOWS
 - E) 180 DEGREES MAX. BETWEEN THE JEA/DEVELOPER INSTALLED CONDUIT AND METER SOCKET
4. WARNING TAPE INSTALLATION REQUIRED. (SEE DIAGRAM BELOW FOR DIMENSIONS)
5. SERVICES AND METERS MAY NOT BE INSTALLED ON ZERO SIDE OF "ZERO LOT LINE" STRUCTURE.
6. PULL WIRE, MULTI-STRANDED POLY TWINE REQUIRED; USE OF NYLON TWINE IS NOT PERMITTED
7. REFERENCE FIGURE 4.04 RESIDENTIAL SERVICE LATERAL CONDUIT INSTALLATION UG SERVICE FROM OH POLE, IF NOT WITHIN URD.
8. GROUNDING SHALL BE IN ACCORDANCE WITH THE NEC AND LOCAL INSPECTION AUTHORITY REQUIREMENTS.

SERVICE DOWNPIPE WITH FOUNDATION CONFLICT:

1. FOOTER MAY BE CHIPPED OR CUT IF REBAR IS NOT EXPOSED.
2. GRADUAL BEND OF CONDUIT ALLOWED BY HEATING AND BENDING OF CONDUIT. NO WRINKLES PERMITTED.
3. DOWNPIPE MUST BE INSTALLED FLUSH AGAINST SIDE OF STRUCTURE.
4. 45 DEGREE ELBOW MAY NOT BE INSTALLED ABOVE FINAL GRADE.

ELBOW SERVICE DOWNPIPE
OUTSIDE WALL WITHOUT
FOUNDATION CONFLICT OR
INSTALLED WITHIN WALL

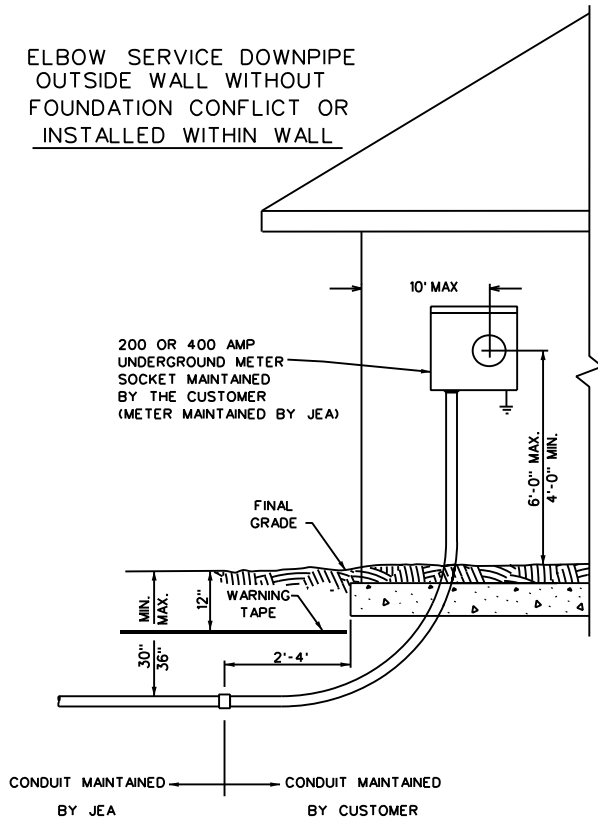

ELBOW SERVICE DOWNPIPE
OUTSIDE WALL WITH
FOUNDATION CONFLICT.

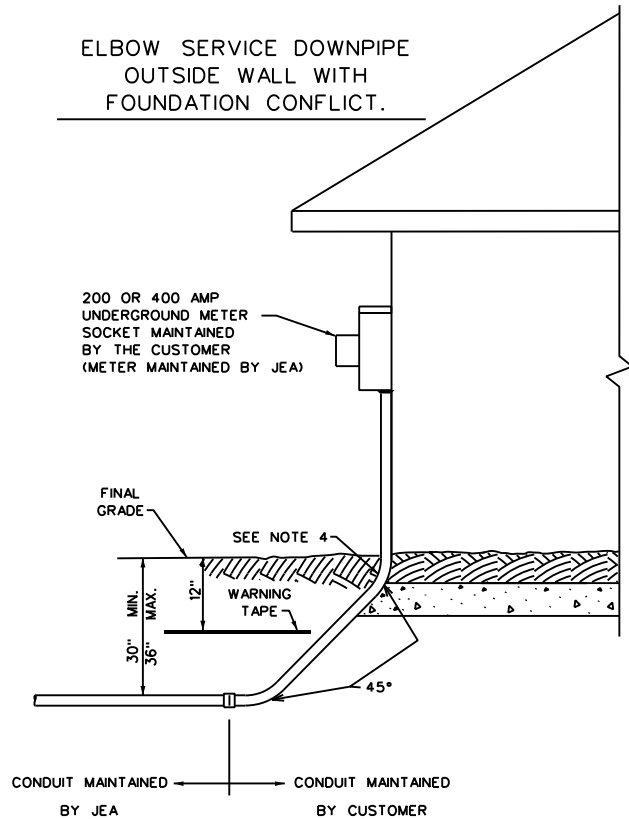

APP'D:	DRN: WILSON
DATE : 09-28-94	4-2-99
10-12-95	10-8-01
10-24-96	1-18-04
11-4-96	5-12-97
09-01-07	02-11-21

RESIDENTIAL SERVICE LATERAL INSTALLATION
UG SERVICE
(URD & UG SERVICE FROM OH POLE)

SCALE:
NONE

JEA
RULES AND REGULATIONS
JACKSONVILLE, FLORIDA

FIGURE: 4.01

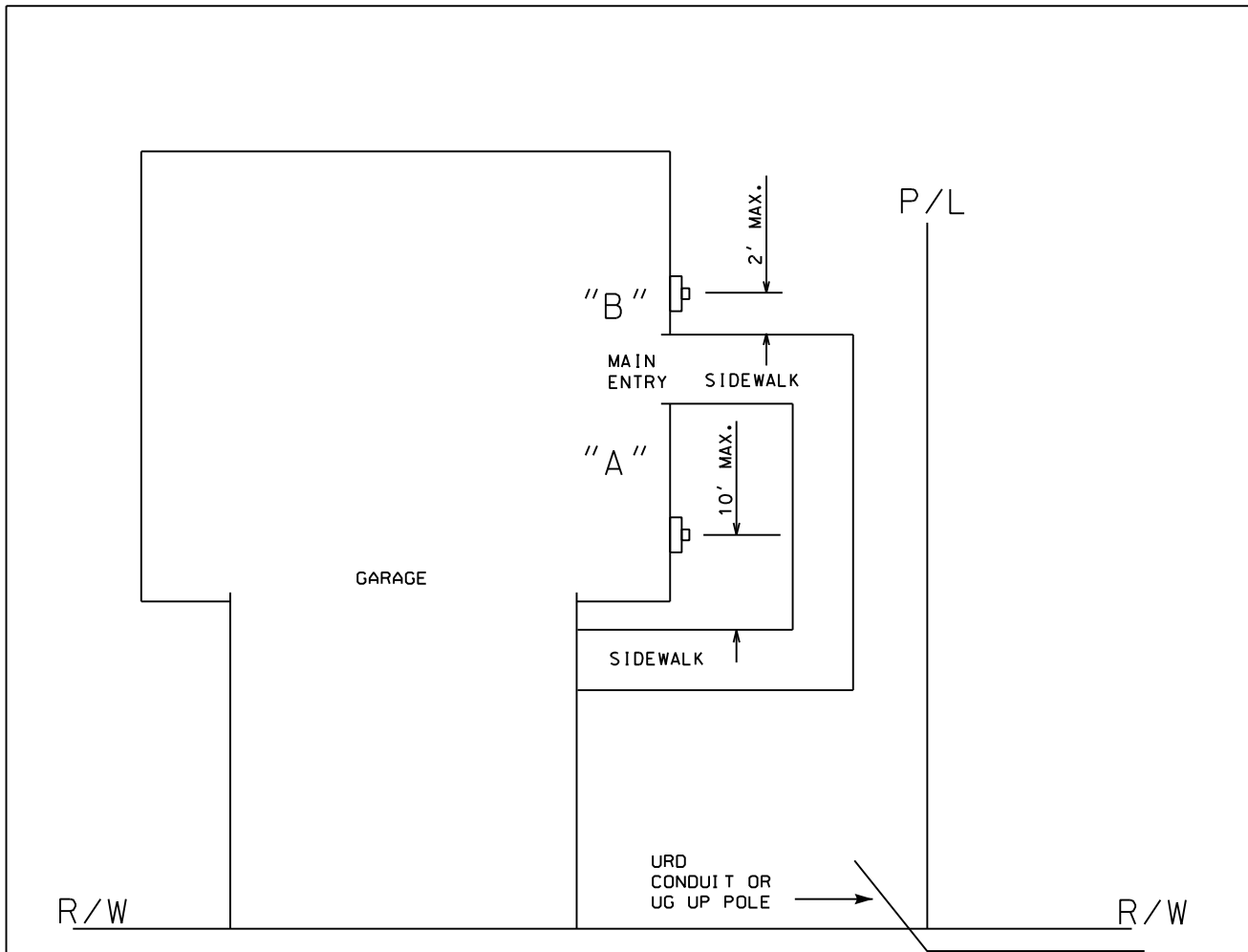

NOTES:

1. METER MUST BE LOCATED WITHIN 10' OF THE CORNER CLOSEST TO THE JEA/DEVELOPER INSTALLED SERVICE CONDUIT AND ON THE SAME SIDE OF THE STRUCTURE AS THE SERVICE CONDUIT FOR THAT PARTICULAR LOT. REFERENCE SECTION 2.06, SERVICE LOCATION.

EXCEPTION: FOR CONSTRUCTION CONFLICTS (SIDE ENTRY DOORS WITH SIDEWALK FLUSH WITH BUILDING) THE METER MAY BE INSTALLED AS SHOWN. THE METER MUST BE ON THE SAME SIDE OF THE STRUCTURE AS THE CONDUIT STUB-OUT OR JEA POLE FOR THAT PARTICULAR LOT.

- I. LOCATION "A": WHERE THERE IS 12" OR GREATER BETWEEN THE SIDEWALK AND THE BUILDING, THE METER MUST BE INSTALLED WITHIN 10' OF CORNER OF THE STRUCTURE.
- II. LOCATION "B": WHERE THERE IS LESS THAN 12" BETWEEN THE SIDEWALK AND THE STRUCTURE, THE METER MUST BE INSTALLED MAXIMUM 2' FROM ENTRYWAY TO CENTERLINE OF METER.

A SAFE WORKING SPACE AROUND METER SOCKET(S)/ENCLOSURE(S) MUST REMAIN FREE OF ALL OBSTRUCTION. THE SPACE REQUIRED WILL BE 2 FEET ON EACH SIDE OF THE SOCKET(S)/ENCLOSURE(S) AND 4 FEET IN FRONT OF THE SOCKET(S)/ENCLOSURE(S).

APP'D:	DRN: JSM	RESIDENTIAL METER LOCATION UG SERVICE (URD & UG SERVICE FROM OH POLE) FRONT ENTRY GARAGE WITH SIDE ENTRY DOOR & SIDEWALK	
DATE : 09-12-01			
SCALE: NONE	JEA RULES AND REGULATIONS JACKSONVILLE , FLORIDA		FIGURE: 4.01A

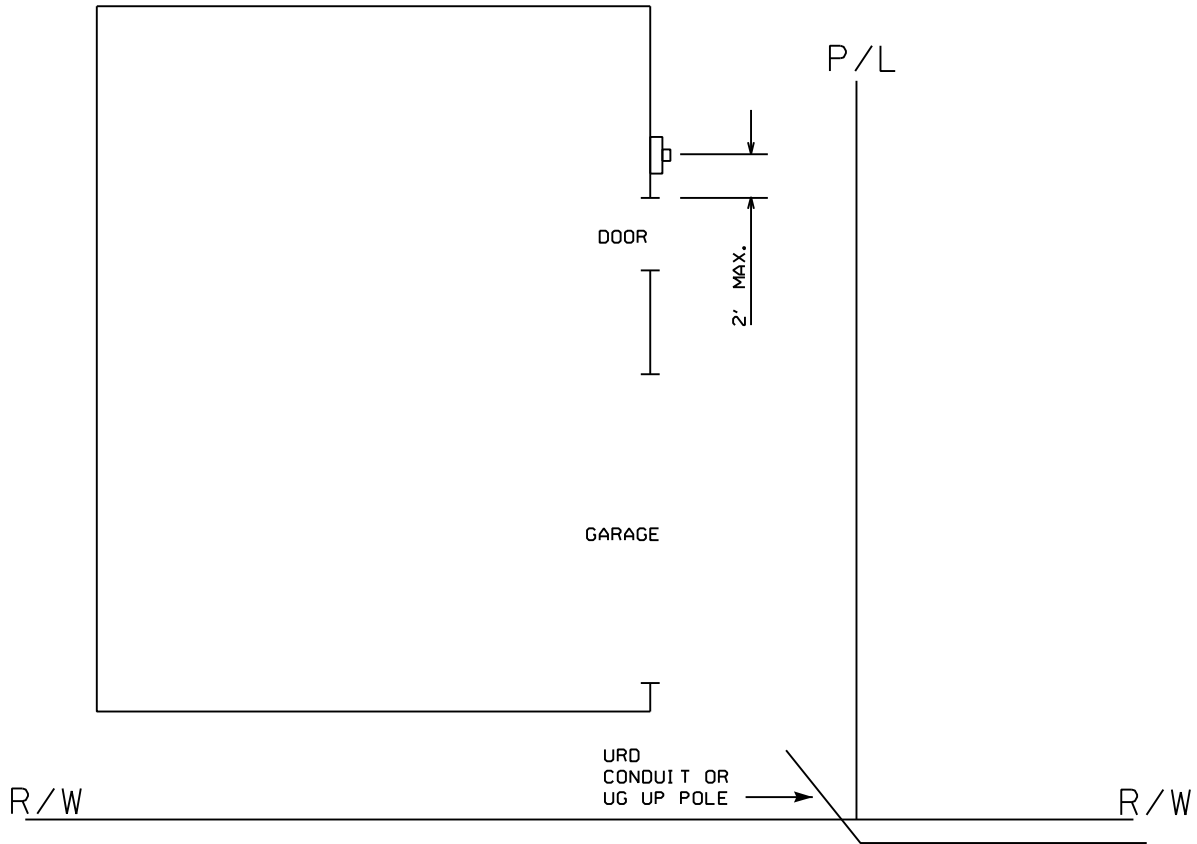

NOTES:

- METER MUST BE LOCATED WITHIN 10' OF THE CORNER CLOSEST TO THE JEA/DEVELOPER INSTALLED SERVICE CONDUIT AND ON THE SAME SIDE OF THE STRUCTURE AS THE JEA/DEVELOPER INSTALLED CONDUIT FOR THAT PARTICULAR LOT. REFERENCE SECTION 2.06, SERVICE LOCATION.

EXCEPTION: FOR CONSTRUCTION CONFLICTS (SIDE ENTRY GARAGE AND/OR DOORS, ETC.) THE METER MAY BE INSTALLED AS SHOWN. (MAXIMUM 2 FT FROM ENTRYWAY TO CENTERLINE OF METER) THE METER MUST BE ON THE SAME SIDE OF THE STRUCTURE AS THE CONDUIT STUB-OUT OR JEA POLE FOR THAT PARTICULAR LOT.

A SAFE WORKING SPACE AROUND METER SOCKET(S)/ENCLOSURE(S) MUST REMAIN FREE OF ALL OBSTRUCTION. THE SPACE REQUIRED WILL BE 2 FEET ON EACH SIDE OF THE SOCKET(S)/ENCLOSURE(S) AND 4 FEET IN FRONT OF THE SOCKET(S)/ENCLOSURE(S).

APP'D:	DRN: JSM	RESIDENTIAL METER LOCATION UG SERVICE (URD & UG SERVICE FROM OH POLE) SIDE ENTRY GARAGE WITH SIDE ENTRY DOOR	
DATE : 09-12-01			
SCALE: NONE	JEA RULES AND REGULATIONS JACKSONVILLE , FLORIDA		FIGURE: 4.01B

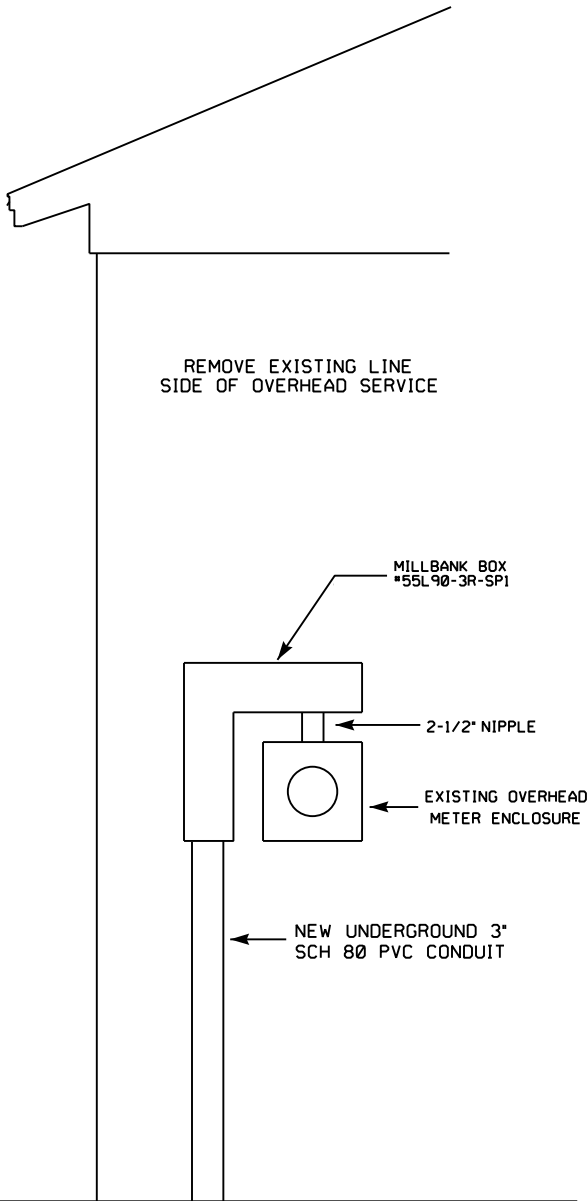

RESIDENTIAL HOUSE SERVICE

NOT TO SCALE

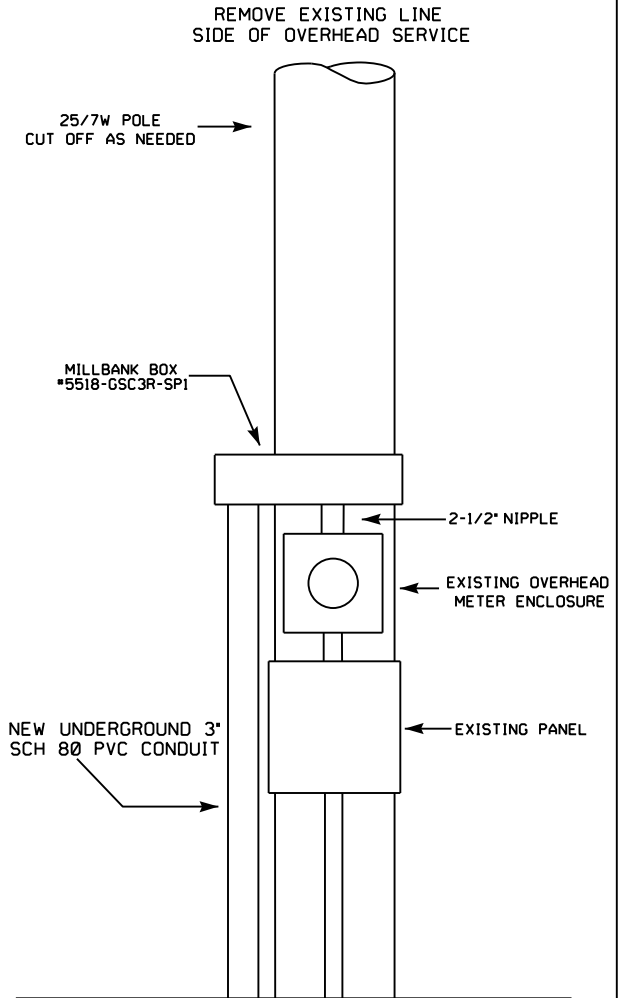

RESIDENTIAL TRAILER POLE SERVICE

NOT TO SCALE

NOTES:

1. REFERENCE SECTION 4.10 FOR REQUIREMENTS.
2. CONTACT JEA SERVICE ENGINEER TO CHECK EXISTING METER LOCATION AND APPROVE THE USE OF THIS TYPE OF UNDERGROUND CONVERSION.
3. CUSTOMER MAINTAINS ALL EQUIPMENT ATTACHED TO CUSTOMER'S STRUCTURE. SEE FIGURE 4.01 AND 4.04 FOR ADDITIONAL INFORMATION.
4. JEA MAINTAINS SECONDARY WIRE TO CUSTOMER'S METER ENCLOSURE.

APP'D:	DRN:SGT/DAH
DATE : 1/22/04	

OVERHEAD TO UNDERGROUND CONVERSION OF EXISTING RESIDENTIAL SERVICE WITH NO INCREASE IN SERVICE SIZE		
SCALE: NONE	JEA RULES AND REGULATIONS JACKSONVILLE , FLORIDA	FIGURE:4.01C

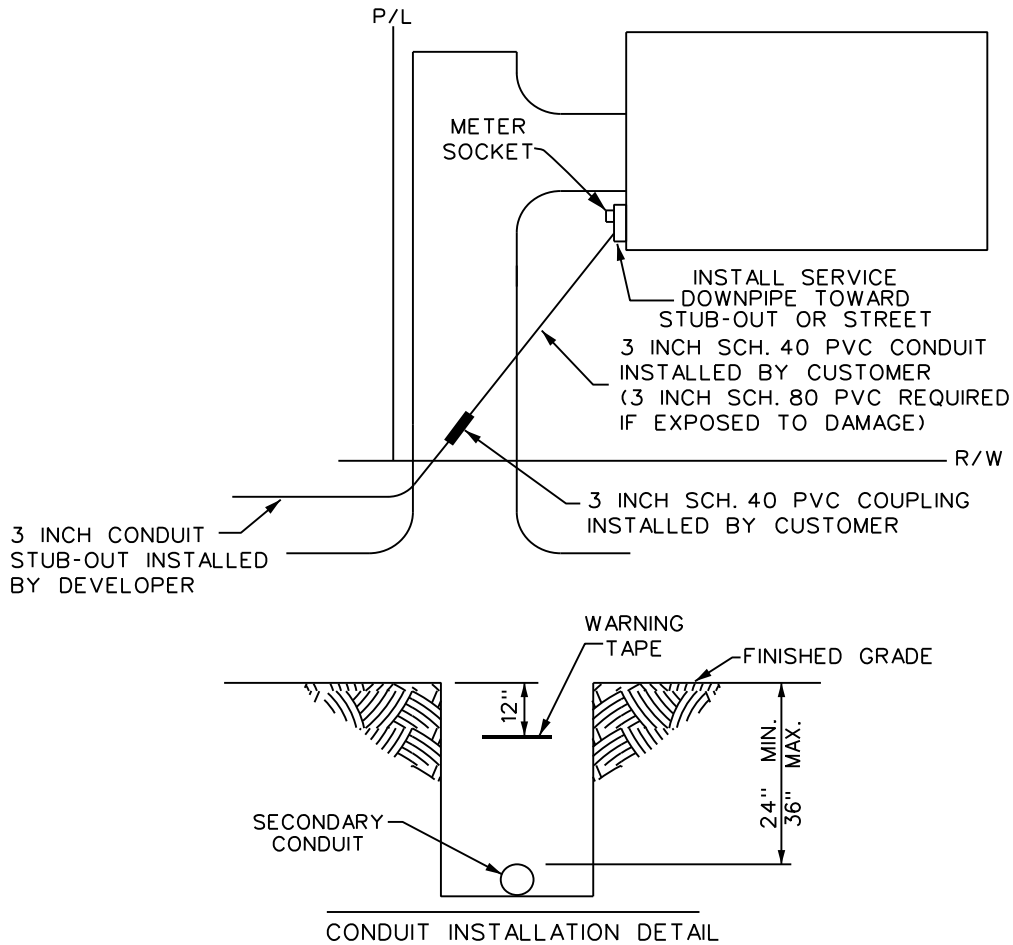

NOTES:

1. GENERAL:

- a. REFERENCE FIGURE 4.01 FOR MINIMUM REQUIREMENTS
- b. SERVICE DOWNPIPE TO BE INSTALLED TOWARD STUBOUT OR STREET
- c. 36 INCH RADIUS FOR ALL ELBOWS
- d. 180 DEGREES MAXIMUM BETWEEN THE JEA/DEVELOPER INSTALLED CONDUIT AND METER SOCKET.

2. FOR CONSTRUCTION CONFLICTS:

EXCEPTION MAY BE ALLOWED FOR STRUCTURES WHERE THE SERVICE CAN NOT BE INSTALLED ON THE SAME SIDE AS THE CONDUIT STUB-OUT. MUST BE APPROVED BY JEA SERVICE ENGINEER PRIOR TO CONDUIT/METER SOCKET INSTALLATION BY CUSTOMER. JEA WILL NOT BE BOUND BY EXCEPTIONS CLAIMED TO HAVE BEEN GIVEN ORALLY.
REFERENCE FIGURES 4.01A AND 4.01B

APP'D:	DRN: GERRISH	RESIDENTIAL SERVICE LATERAL CONDUIT INSTALLATION UG SERVICE (URD) SERVICE SIZE: 400 AMP MAXIMUM	
DATE: 11-12-92 1-18-03 10-12-95 02-11-21 10-24-96 5-12-97 4-2-99	SCALE: NONE		

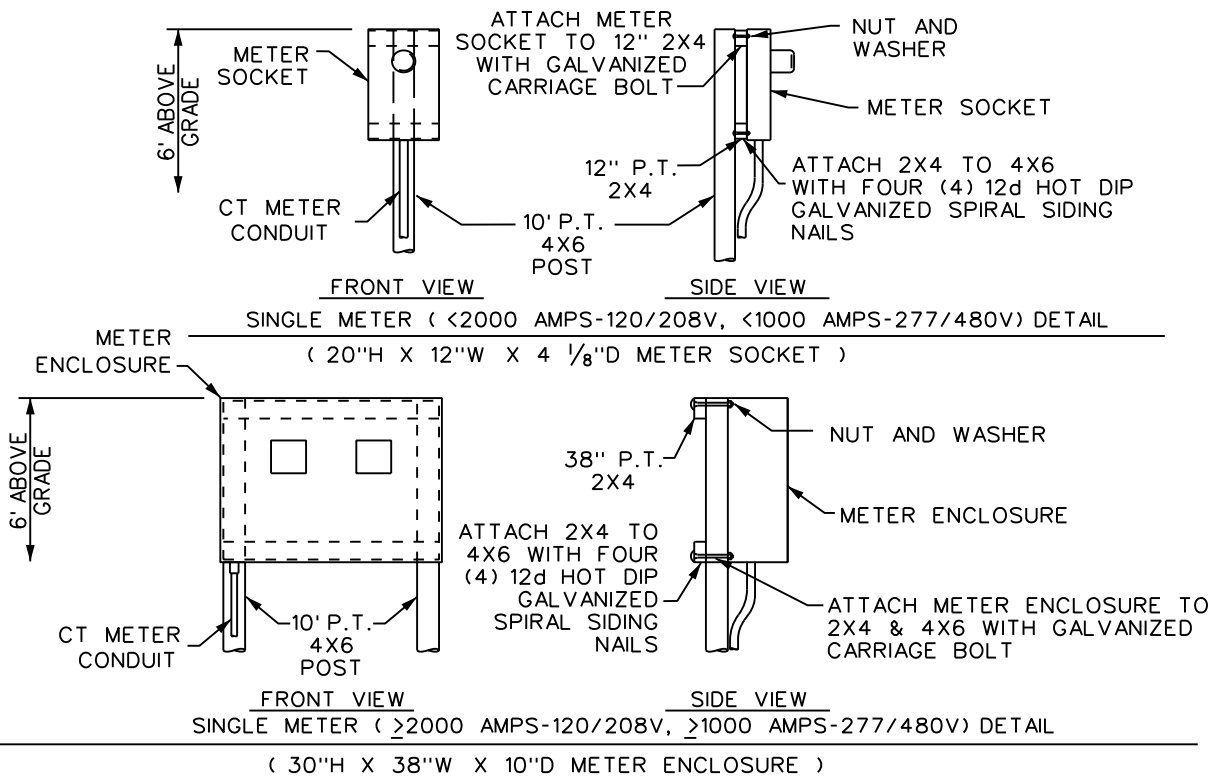

POLE SUPPORT MATERIAL :

1. 4X6 AND 2X4 TO BE #2 GRADE SOUTHERN YELLOW PINE, SMOOTH ALL FOUR (4) SIDES, PRESSURE TREATED WITH C.C.A. TYPE C, 0.6 LBS. PER CU. FT. RETENTION. (TREATMENT LEVEL MUST BE STAMPED ON 2X4 AND 4X6.)
2. 3" GALVANIZED METAL POST WITH CAPPED TOP.
3. 4"X4" REINFORCED CONCRETE (3000 PSI)
4. METER PEDESTAL TO BE SET IN CONCRETE (REFERENCE FIGURE 4.07)

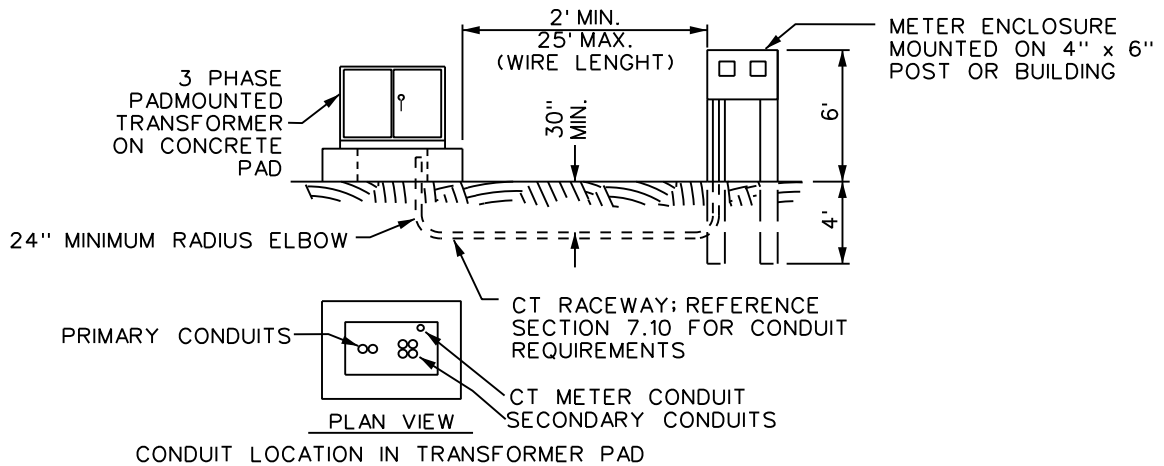

APP'D:	DRN: WILSON	CURRENT TRANSFORMER PADMOUNTED INSTALLATION 3 PHASE UG SERVICE	
DATE:	12-03-92 1-18-04 10-12-95 3-1-10 10-24-96 11-4--96 5-12-97 4-2-99		
SCALE:	NONE	JEA RULES AND REGULATIONS JACKSONVILLE , FLORIDA	FIGURE: 4.03

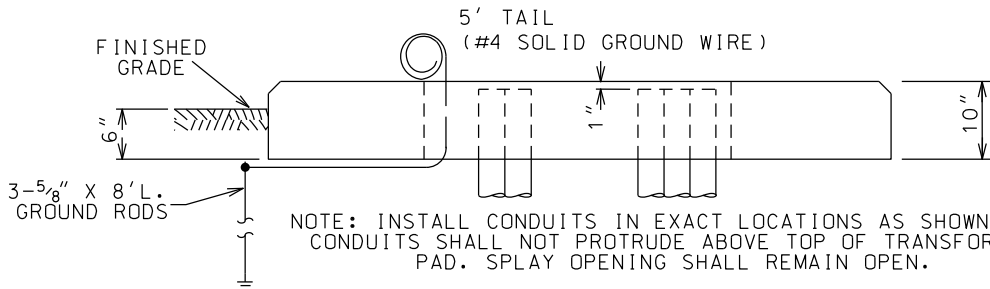
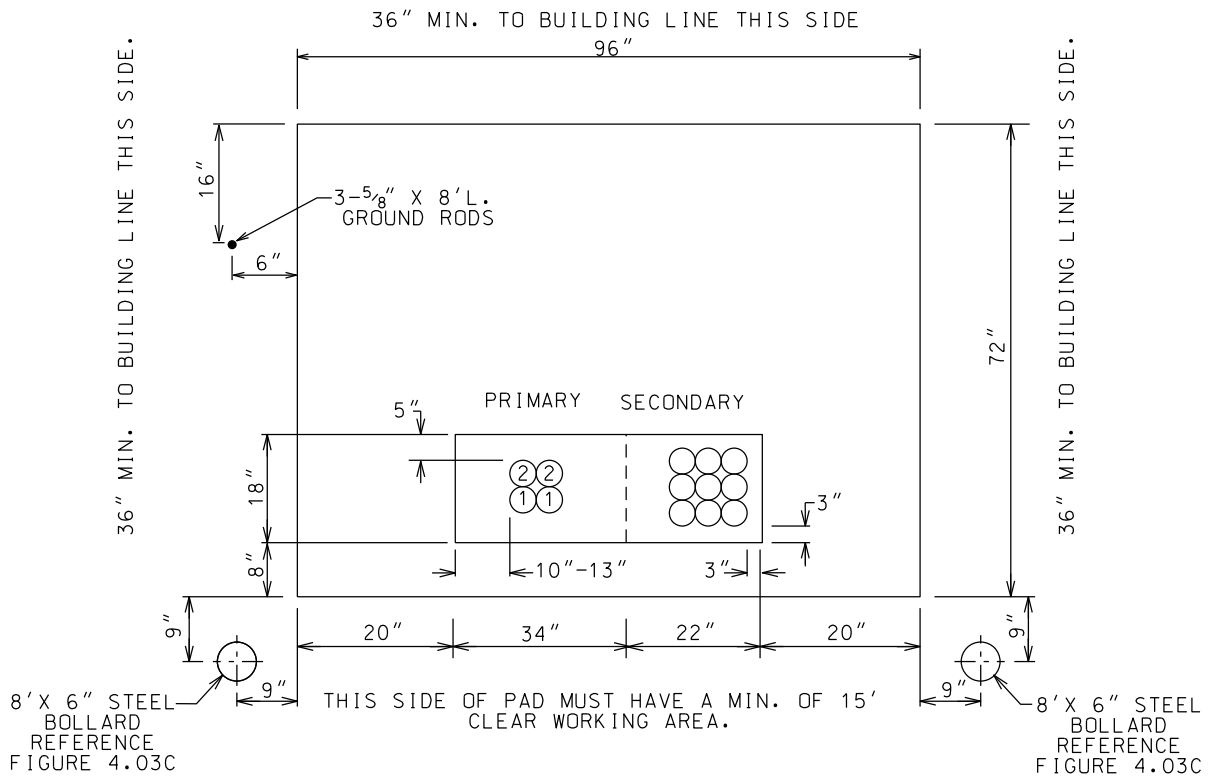

NOTE: TRANSFORMER PAD TO BE SET WITHIN 10' OF DRIVABLE SURFACE

NOTES:

1. TRANSFORMER PAD PROVIDED BY JEA.
2. CONTACT JEA SERVICE ENGINEER FOR REINFORCING BAR SPECIFICATIONS IF CUSTOMER CHOOSES TO FRAME AND POUR TRANSFORMER PAD.

SECONDARY CONDUIT AVAILABLE OPTIONS: CONDUIT LOCATIONS TO BE DETAILED BY JEA SERVICE ENGINEER

CONDUIT SIZE: 4"

MAXIMUM SETS OF SECODARY: 9

APP'D:	DRN: SIMMONS	TRANSFORMER PAD DETAIL UG SERVICE 75-500 KVA, 3 PHASE	
DATE : 4-6-99 10-8-01 1-18-04 09-01-07 01-01-17			
		FIGURE:4.03A	

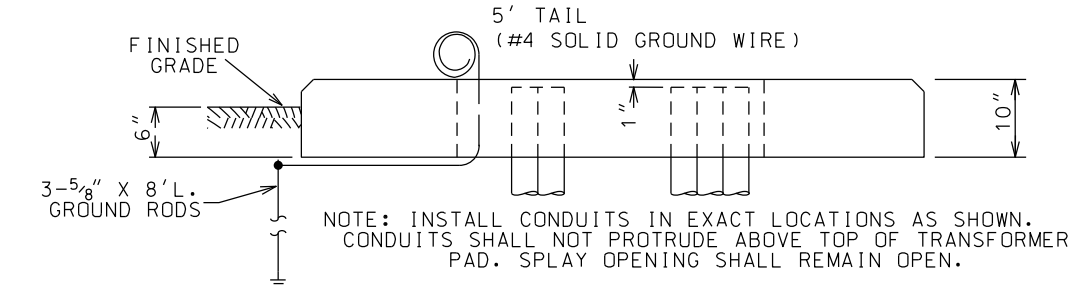
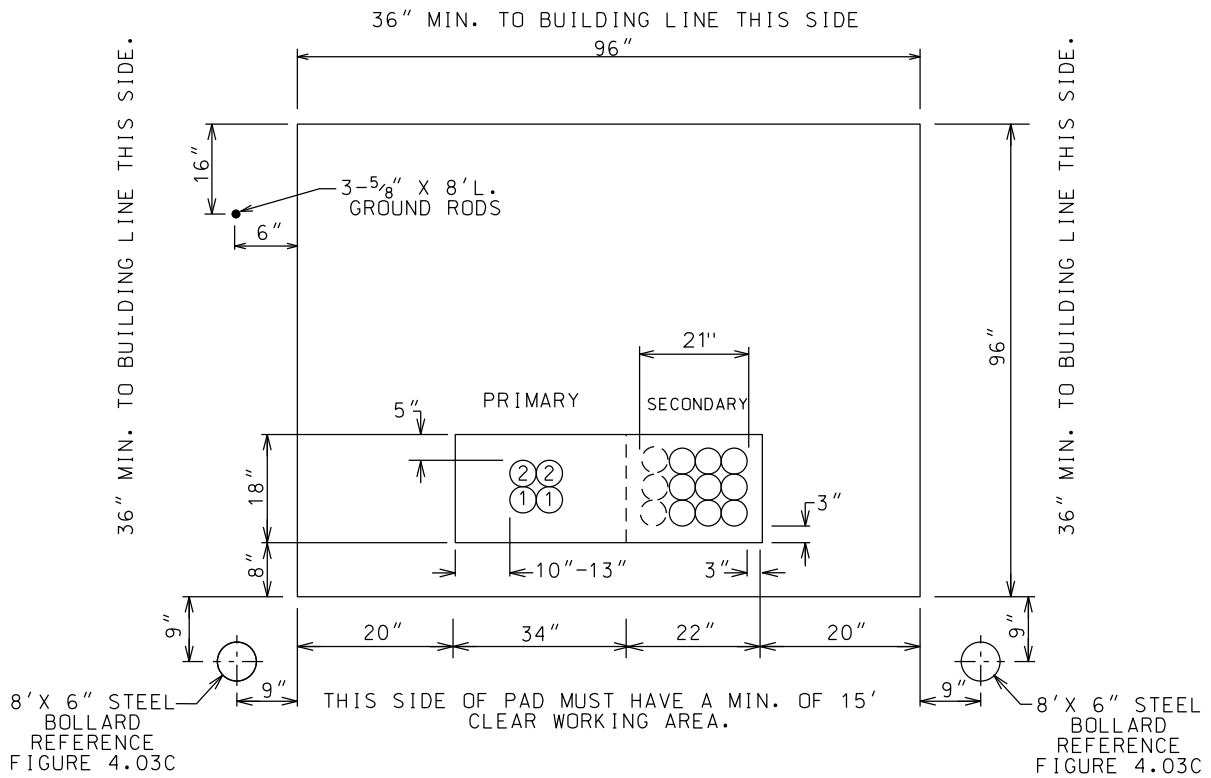

NOTE: TRANSFORMER PAD TO BE SET WITHIN 10' OF DRIVABLE SURFACE

NOTES:

1. TRANSFORMER PAD PROVIDED BY JEA.
2. CONTACT JEA SERVICE ENGINEER FOR REINFORCING BAR SPECIFICATIONS IF CUSTOMER CHOOSES TO FRAME AND POUR TRANSFORMER PAD.

SECONDARY CONDUIT AVAILABLE OPTIONS: CONDUIT LOCATIONS TO BE DETAILED BY JEA SERVICE ENGINEER

TRANSFORMER SIZE	CONDUIT SIZE: 4"	MAXIMUM SETS OF SECONDARY
UP TO 1500 KVA		9
1500 & 2000 KVA		10
2500 KVA OR LARGER		12

APP'D:	DRN: SIMMONS	TRANSFORMER PAD DETAIL UG SERVICE 750 - 3750 KVA, 3 PHASE	
DATE : 4-6-99 09-23-20 1-18-04 12-15-23 09-01-07 01-01-17			
SCALE:	NONE	JEA RULES AND REGULATIONS JACKSONVILLE, FLORIDA	FIGURE: 4.03B

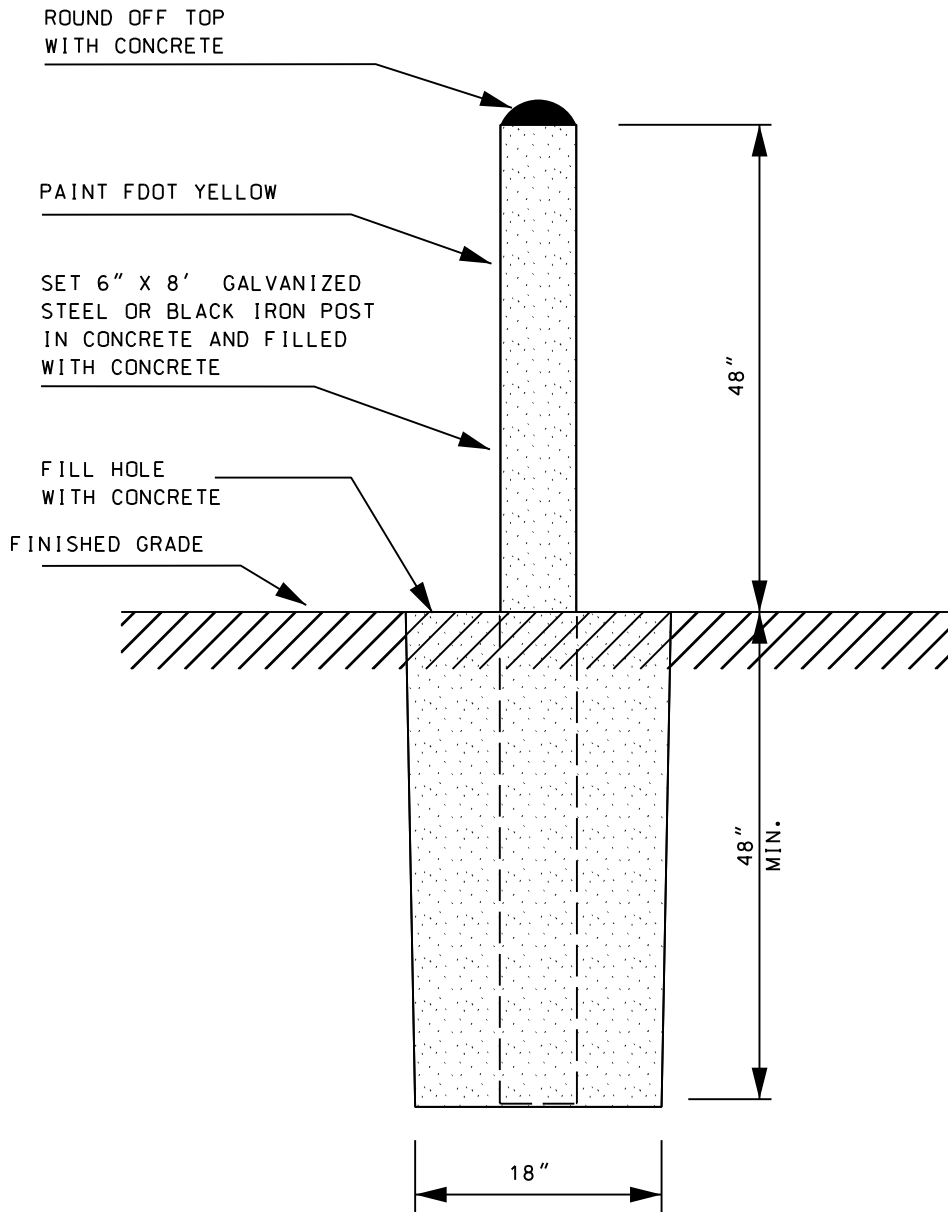

NOTE: GUARD STRUCTURE FOR JEA EQUIPMENT
EXPOSED TO VEHICULAR TRAFFIC
OR AS DESIGNATED BY JEA SERVICE ENGINEER

APP'D:	DRN: WILSON
DATE : 6-26-96 10-24-96 11-4-96 4-2-99 10-8-01	

BOLLARD DETAIL

SCALE:
NONE

JEA
RULES AND REGULATIONS
JACKSONVILLE , FLORIDA

FIGURE:4.03C

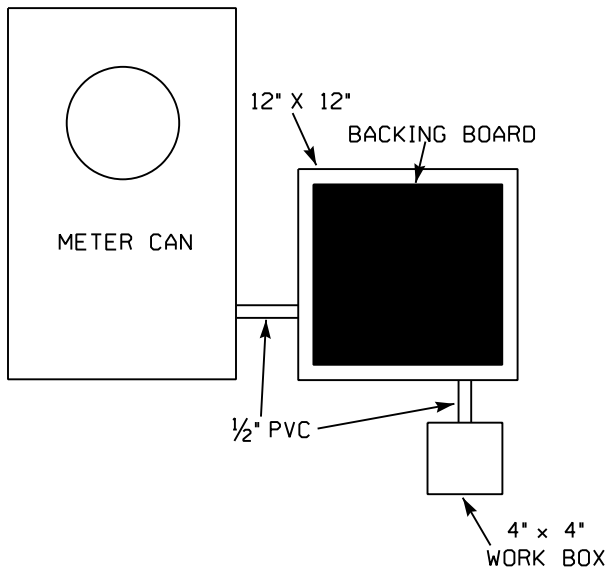

SINGLE GANG METER ENCLOSURE:

A SEALABLE WATERPROOF ENCLOSURE 12" x 12" x 4" WITH A 1/2" PLYWOOD BACKING BOARD CONNECTED TO THE METER ENCLOSURE WITH 1/2" PVC RACEWAY. ATTACHED TO THIS ENCLOSURE WILL BE A 4" x 4" WORK BOX FOR THE CUSTOMER'S CONNECTIONS.

SINGLE GANG METER ENCLOSURE:

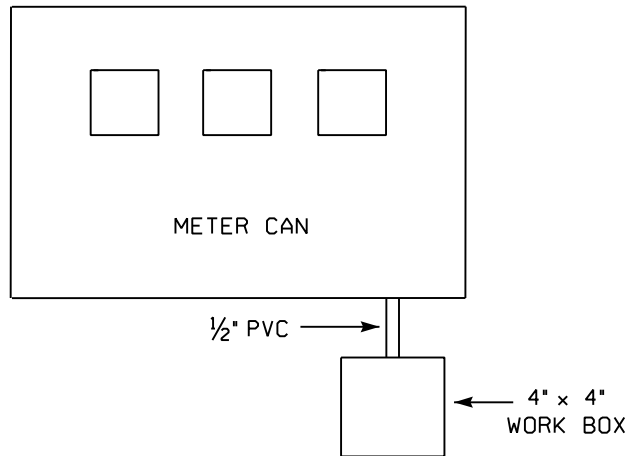

THREE GANG METER ENCLOSURE:

APP'D:	DRN: DAH	INSTALLATION OF IMPULSE GENERATION EQUIPMENT	
DATE :02/14/04			
SCALE: NONE	JEA RULES AND REGULATIONS JACKSONVILLE , FLORIDA	FIGURE:4.03D	

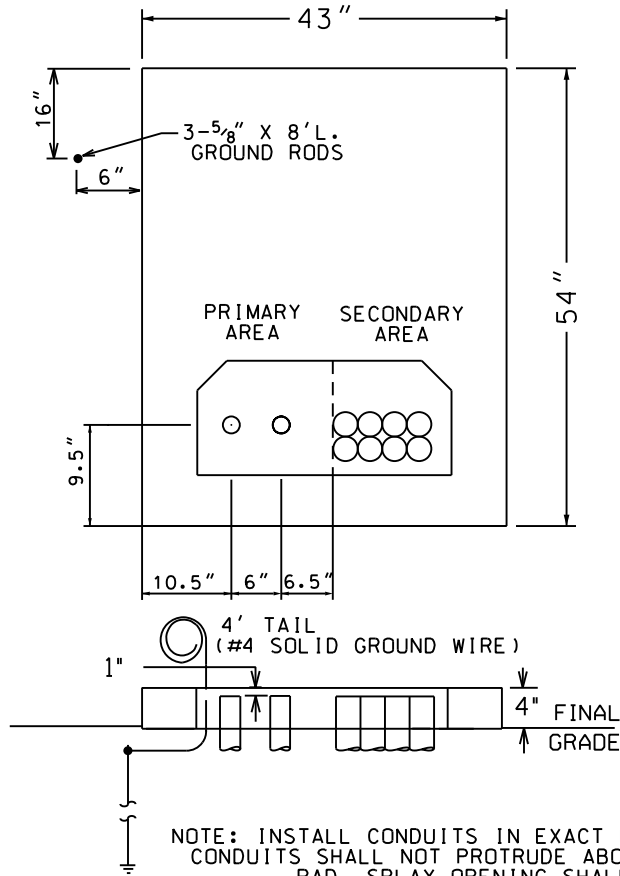

SECONDARY CONDUIT AVAILABLE OPTIONS: CONDUIT LOCATIONS TO BE DETAILED BY
JEA SERVICE ENGINEER

<u>CONDUIT SIZE</u>	<u>MAXIMUM NUMBER OF CONDUITS</u>
2"	12
3"	8
4"	6
6"	2

NOTE: SEE JEA UNDERGROUND CONSTRUCTION STANDARD MANUAL
FOR OPEN DELTA CONDUIT CONFIGURATION AND WIRE INSTALLATION

APP'D:	DRN: ACS	TRANSFORMER PAD DETAIL UG SERVICE 1 PHASE	
DATE : 09-01-07 05-01-13 01-01-17 10-26-20			
SCALE:	NONE	JEA RULES AND REGULATIONS JACKSONVILLE , FLORIDA	FIGURE: 4.03E

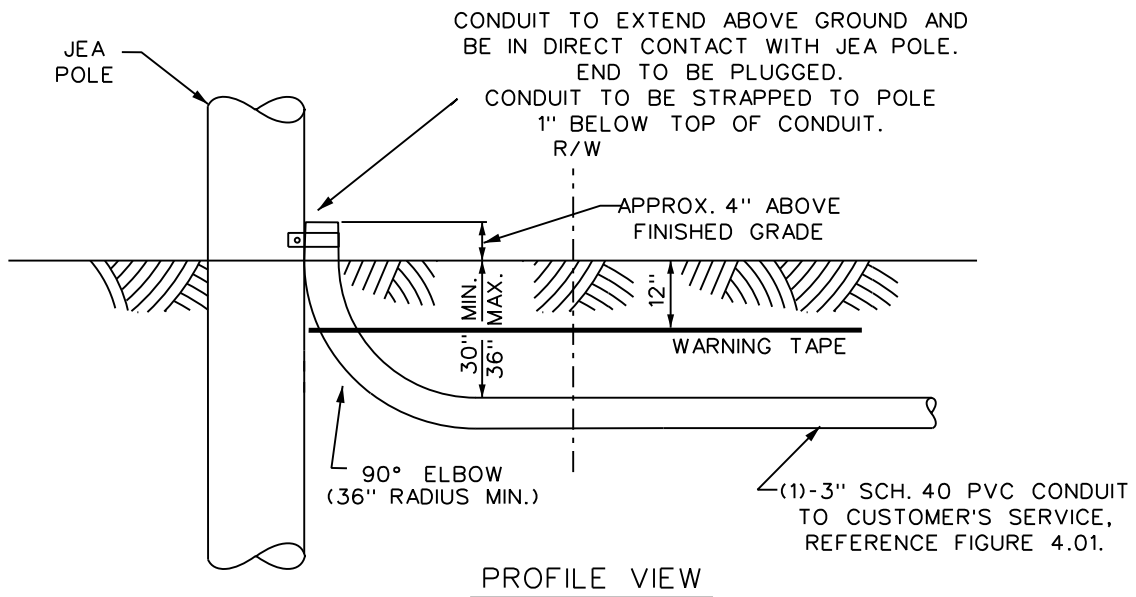
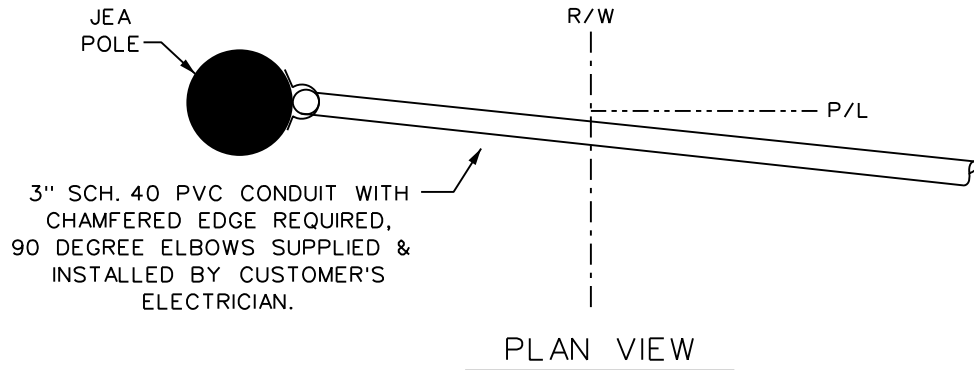

APP'D:	DRN: WILSON
DATE : 09-20-94	01-01-17
10-12-95	
11-18-96	
4-2-99	
10-8-01	
1-18-04	

RESIDENTIAL SERVICE LATERAL
CONDUIT INSTALLATION
UG SERVICE FROM OH POLE

SCALE:
NONE

JEA
RULES AND REGULATIONS
JACKSONVILLE, FLORIDA

FIGURE: 4.04

NOTES:

1. 300 AMP MAXIMUM SERVICE SIZE; FOR LARGER SERVICES, CONTACT JEA SERVICE ENGINEER
2. JEA SHALL:
 - DESIGNATE JEA POLE LOCATION (LOCATION IS DEPENDENT UPON FIELD CONDITIONS AND SERVICE SIZE)
 - INSTALL AND MAINTAIN THE SECONDARY SERVICE LATERAL FROM THE JEA OH FACILITIES TO THE POINT OF SERVICE
 - MAINTAIN THE SECONDARY CONDUIT FROM THE JEA SERVICE POLE TO THE JEA END OF THE CUSTOMER'S SERVICE DOWNPIPE
3. THE CUSTOMER MUST SELECT A CLEAR SIDE OF THE JEA POLE TO INSTALL THE SECONDARY RISER. CLEAR FROM PHONE OR COMMUNICATION CABLES, OR ANY OTHER EQUIPMENT FROM FINISHED GRADE TO OVERHEAD FACILITIES. CONTACT JEA SERVICE ENGINEER IF RISER LOCATION REQUIRED.
4. THE CUSTOMER SHALL INSTALL:
 - 3 INCH SCH 40 PVC SERVICE LATERAL CONDUIT AS SHOWN (CHAMFERED EDGES REQUIRED)
 - WARNING TAPE AS SHOWN
 - POLY PULL WIRE
 - 90 DEGREE ELBOW 36" (MINIMUM) RADIUS
 - (REFERENCE SECTION 4.08 AND FIGURES 4.01, 4.01A AND 4.01B)
5. MAXIMUM 270 DEGREES OF SWEEPS BETWEEN THE METER SOCKET AND THE JEA FACILITIES
6. MOBILE HOME INSTALLATIONS: METER SOCKET SHALL BE MOUNTED ON PEDESTAL (REFERENCE FIGURE 4.07) OR AS DIRECTED BY LOCAL PERMITTING/ZONNING.
7. POINT OF SERVICE:
 - ≤ 400 AMPS - @ THE METER
 - > 400 AMPS - THE LINE SIDE OF THE CT(S)

APP'D:	DRN: WILSON	RESIDENTIAL SERVICE LATERAL CONDUIT INSTALLATION UG SERVICE FROM OH POLE	
DATE : 09-20-94 09-01-07 10-12-95 01-01-17 11-18-96 4-2-99 10-8-01 1-18-04		SCALE: NONE	JEA RULES AND REGULATIONS JACKSONVILLE , FLORIDA
			FIGURE: 4.04

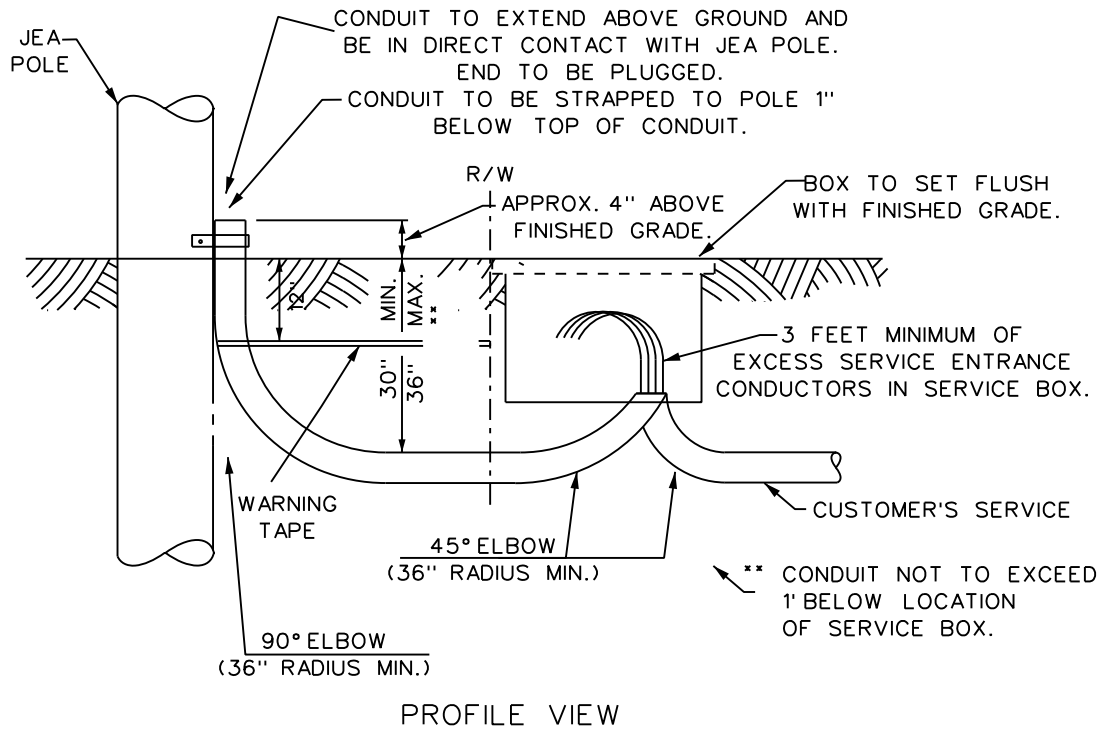
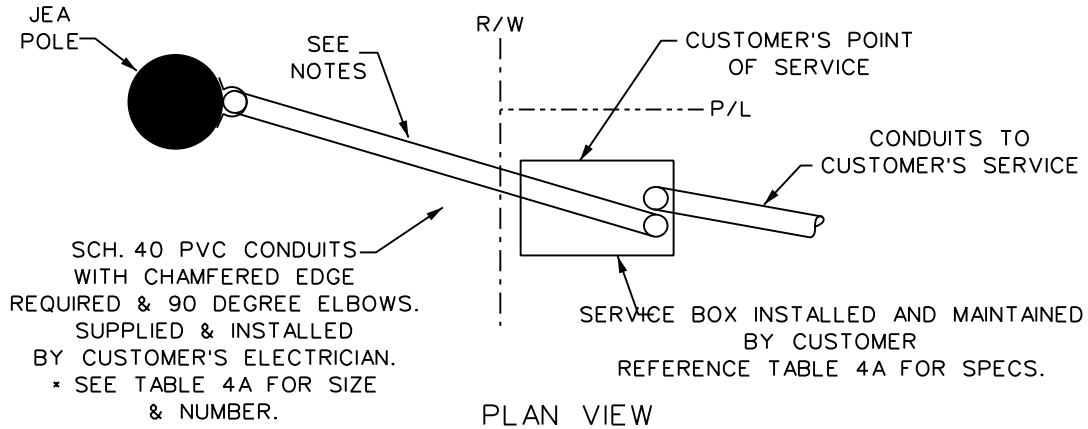

APP'D:	DRN: WILSON	CONDUIT/SERVICE BOX INSTALLATION (COMMERCIAL SERVICE & MULTI-METERED SERVICE) UG SERVICE FROM OH POLE	
DATE : 09-20-94 10-08-01 10-12-95 01-18-04 10-24-96 09-01-07 11-04-96 05-01-11 05-12-97 05-01-13 04-05-99 01-01-17	SCALE: NONE		

NOTES:

1. JEA SHALL:
 - A. DESIGNATE JEA POLE AND SERVICE BOX LOCATION. THE SERVICE BOX SHALL BE INSTALLED ON CUSTOMER/PRIVATE PROPERTY AS CLOSE TO THE PROPERTY LINE AND R/W LINE AS PRACTICAL.
 - B. MAKE ALL CONNECTIONS TO THE CUSTOMER'S SERVICE CONDUCTORS IN THE SERVICE BOX.
 - C. MAINTAIN THE SECONDARY RISER FROM OVERHEAD CONNECTIONS TO THE CONNECTIONS IN THE SERVICE BOX.
 - D. MAINTAIN CONDUIT(S) BETWEEN JEA SERVICE POLE AND SERVICE BOX.

2. THE CUSTOMER MUST SELECT A CLEAR SIDE OF THE JEA POLE FOR JEA TO INSTALL THE SECONDARY RISER. CLEAR FROM PHONE OR COMMUNICATION CABLES, OR ANY OTHER EQUIPMENT, FROM FINISHED GRADE TO OVERHEAD FACILITIES.
CONTACT JEA SERVICE ENGINEER IF RISER LOCATION REQUIRED.

3. CUSTOMER SHALL:
 - A. INSTALL WARNING TAPE FROM THE SERVICE BOX TO THE JEA SERVICE POLE AS SHOWN.

4. CUSTOMER SHALL INSTALL AND MAINTAIN:
 - A. SERVICE BOX.
 - I. THE SERVICE BOX SHALL BE LOCATED FROM THE JEA SERVICE POLE:
 - MINIMUM 4'
 - MAXIMUM 10', OR AS DESIGNATED BY JEA SERVICE ENGINEER
 - BE CLEAR OF OBSTRUCTION
 - B. CONDUIT ELL(S) ON THE CUSTOMER'S SIDE OF THE POINT OF SERVICE OR CONDUITS FROM SERVICE BOX TO THE CUSTOMER'S POINT OF METERING OR DISCONNECT/SWITCHGEAR.
 - C. SECONDARY CONDUCTORS FROM THE CONNECTIONS IN THE SERVICE BOX TO THE CUSTOMER'S POINT OF METERING OR DISCONNECT/SWITCHGEAR.

5. POINT OF SERVICE: SECONDARY CONNECTIONS IN THE SERVICE BOX.

6. THE PURPOSE OF THE SERVICE BOX IS TO PREVENT THE CUSTOMER'S FACILITIES FROM BEING INSTALLED ON JEA POLES, NOT TO REDUCE THE LENGTH OF CONDUCTOR INSTALLED BY THE CUSTOMER.

APP'D:	DRN: WILSON	CONDUIT/SERVICE BOX INSTALLATION (COMMERCIAL SERVICE & MULTI-METERED SERVICE) UG SERVICE FROM OH POLE	
DATE : 09-20-94 10-8-01 10-12-95 05-01-11 10-24-96 11-4-96 5-12-97 4-5-99		SCALE: NONE	JEA RULES AND REGULATIONS JACKSONVILLE , FLORIDA
			FIGURE:4.04A

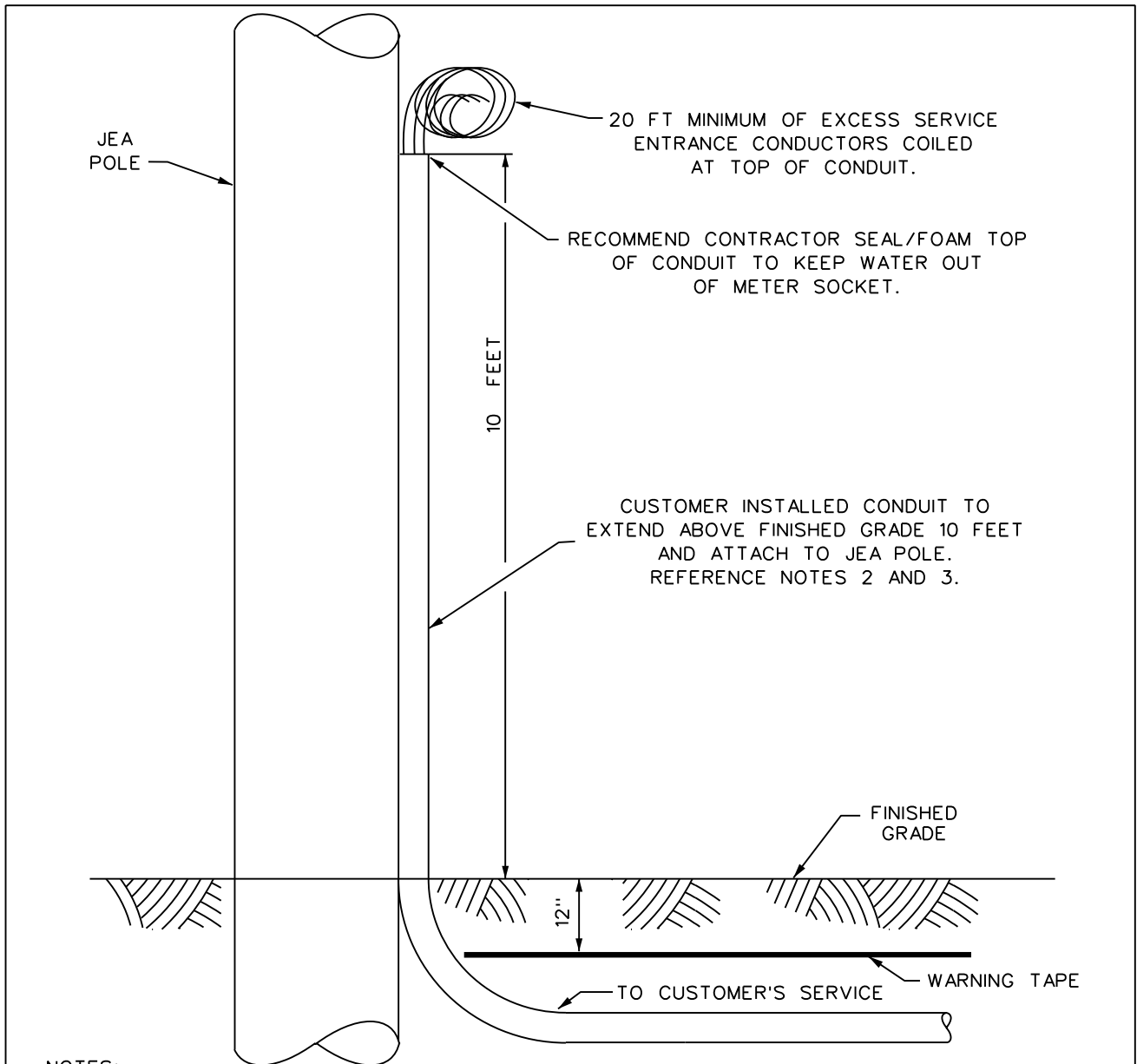

NOTES:

1. MAXIMUM SERVICE SIZE: 100 AMPS 1 OR 3 PHASE. REFERENCE FIGURE 4.04A FOR LARGER SERVICES.
2. THE CUSTOMER MUST SELECT A CLEAR SIDE OF THE JEA POLE FOR THE JEA TO INSTALL THE SECONDARY RISER. CLEAR FROM PHONE OR COMMUNICATION CABLES, OR ANY OTHER EQUIPMENT, FROM FINISHED GRADE TO OVERHEAD FACILITIES. CONTACT JEA SERVICE ENGINEER IF LOCATION REQUIRED.
3. CUSTOMER SHALL INSTALL AND MAINTAIN:
 - CONDUIT TO EXTEND ABOVE FINISHED GRADE 10 FEET (ATTACH TO JEA POLE AS SHOWN).
 - 20 FEET MINIMUM EXCESS SERVICE ENTRANCE CONDUCTORS AT TOP OF CONDUIT AS SHOWN.
 - WARNING TAPE AS SHOWN.
4. JEA SHALL:
 - MAKE ALL CONNECTIONS TO THE CUSTOMER'S SERVICE CONDUCTORS ON THE JEA POLE.
 - INSTALL CABLE GUARD ON THE JEA POLE AND COVER CUSTOMER'S SERVICE CONDUCTOR AND CONDUIT TO FINISHED GRADE.
5. POINT OF SERVICE: SECONDARY CONNECTIONS ON JEA POLE.

APP'D:	DRN: WILSON	CONDUIT/CONDUCTOR INSTALLATION (COMMERCIAL SERVICE 100 AMP MAXIMUM) UG SERVICE FROM OH POLE	
DATE: 09-26-94	08-25-20		
10-12-95		SCALE: NONE	JEA RULES AND REGULATIONS JACKSONVILLE, FLORIDA
10-24-96			
4-5-99			
10-8-01			
1-18-04			

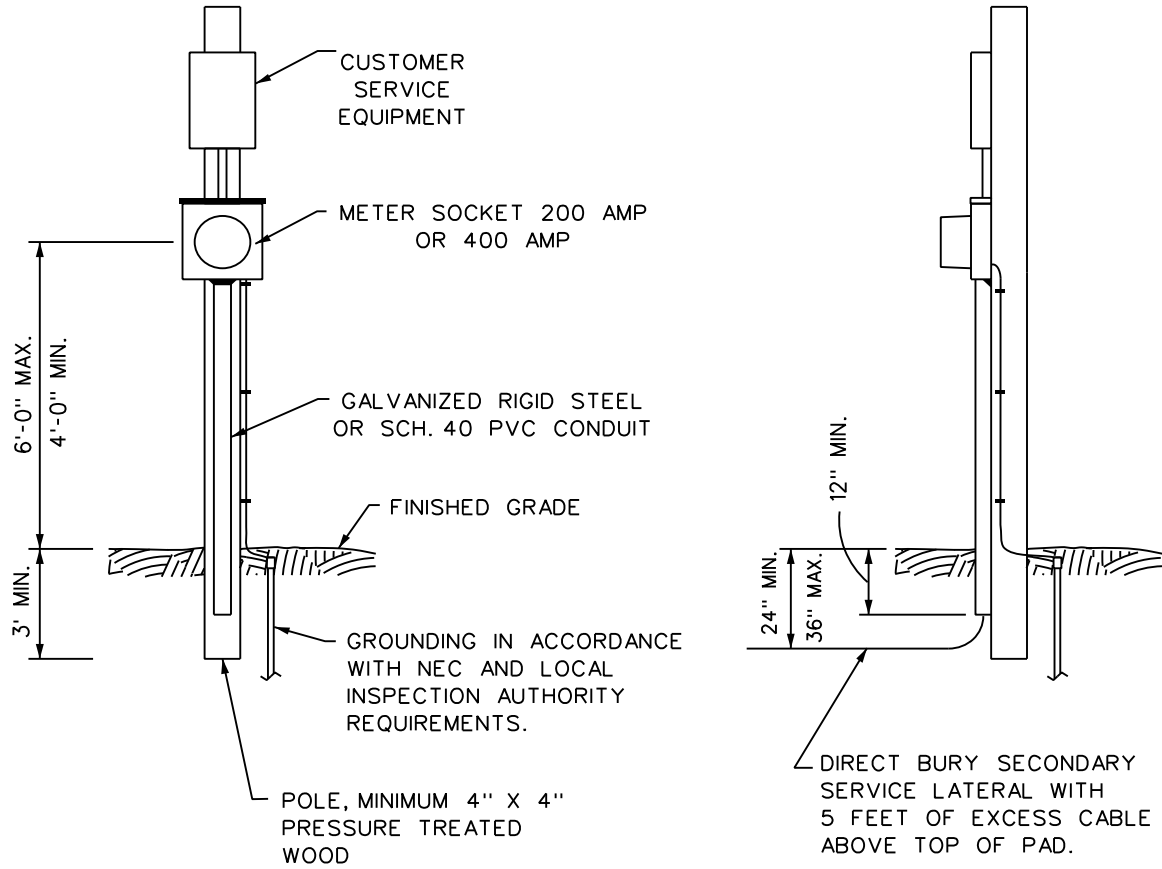

BREAKER/DISCONNECT MAYBE USED IN PLACE OF METER CAN FOR QUALIFIED TPF R SERVICES

APP'D:	DRN: WILSON
DATE :	
09-26-94	
10-12-95	
4-5-99	
08-08-2020	

TEMPORARY POLE
UG SERVICE
SERVICE SIZE:400 AMP MAXIMUM

SCALE:
NONE

JEA
RULES AND REGULATIONS
JACKSONVILLE , FLORIDA

FIGURE:4.05

NOTES:

1. THIS INSTALLATION IS NOT ALLOWED IN ST. JOHNS COUNTY.
2. PERMANENT METER SOCKET TO BE USED AS A SEALABLE TEMPORARY JUNCTION BOX.
3. CUSTOMER SHALL INSTALL:
 - SERVICE LATERAL AND PERMANENT METER. REFERENCE FIGURES 4.01 AND 4.02.
 - TEMPORARY POLE. REFERENCE FIGURE 4.05.
 - REQUIRED SUPPORT: TRIPOD TYPE ATTACHED BELOW THE PERMANENT METER SOCKET. THE CONSTRUCTION OF THE TRIPOD STRUCTURE SHALL PREVENT REPOSITIONING OF THE PERMANENT METER SOCKET UPON INSTALLATION OF THE SERVICE CONDUCTORS BY JEA.
 - 1 INCH PVC BETWEEN THE TWO METER SOCKETS.
 - TEMPORARY SERVICE LATERAL CONDUCTOR; MINIMUM 24 INCH EXCESS INSIDE PERMANENT METER SOCKET. (CUSTOMER SHALL REMOVE THE TEMPORARY SERVICE CONDUCTOR AND PLUG THE KNOCK OUT IN THE METER CAN BEFORE PERMANENT METER INSTALLED)
 - GROUNDING IN ACCORDANCE WITH THE NEC AND LOCAL INSPECTION AUTHORITY REQUIREMENTS.
4. JEA SHALL INSTALL:
 - PERMANENT SERVICE LATERAL CONDUCTORS.
 - CONNECTIONS FOR TEMPORARY SERVICE CONDUCTORS INSIDE PERMANENT METER SOCKET.

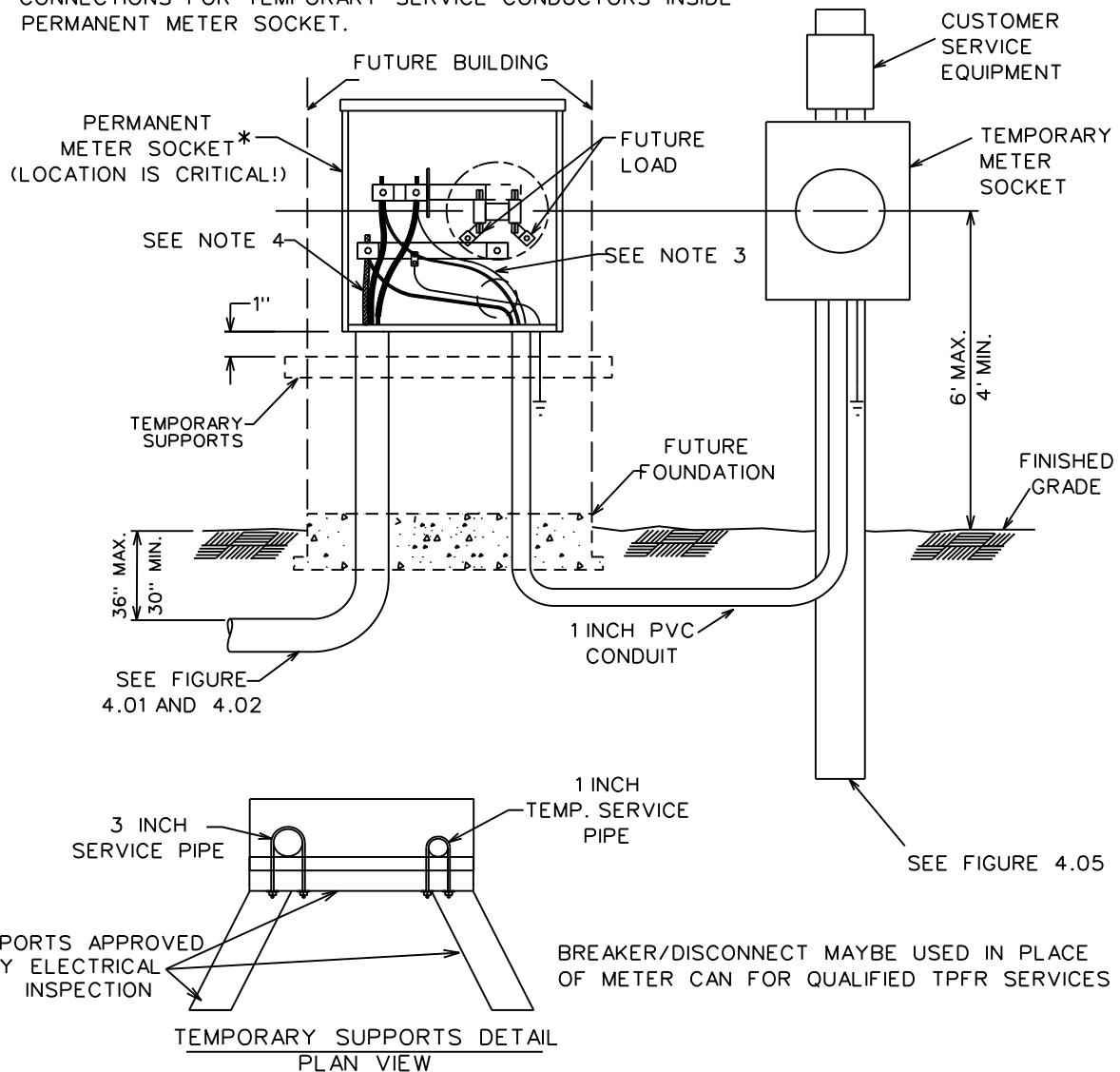

APP'D:	DRN: GERRISH	TEMPORARY SERVICE POLE UG SERVICE SERVICE SIZE: 100 AMP MAXIMUM	
DATE :	11-12-92 10-12-95 4-5-99 08-08-2020		
SCALE:	NONE	JEA RULES AND REGULATIONS JACKSONVILLE, FLORIDA	FIGURE: 4.06

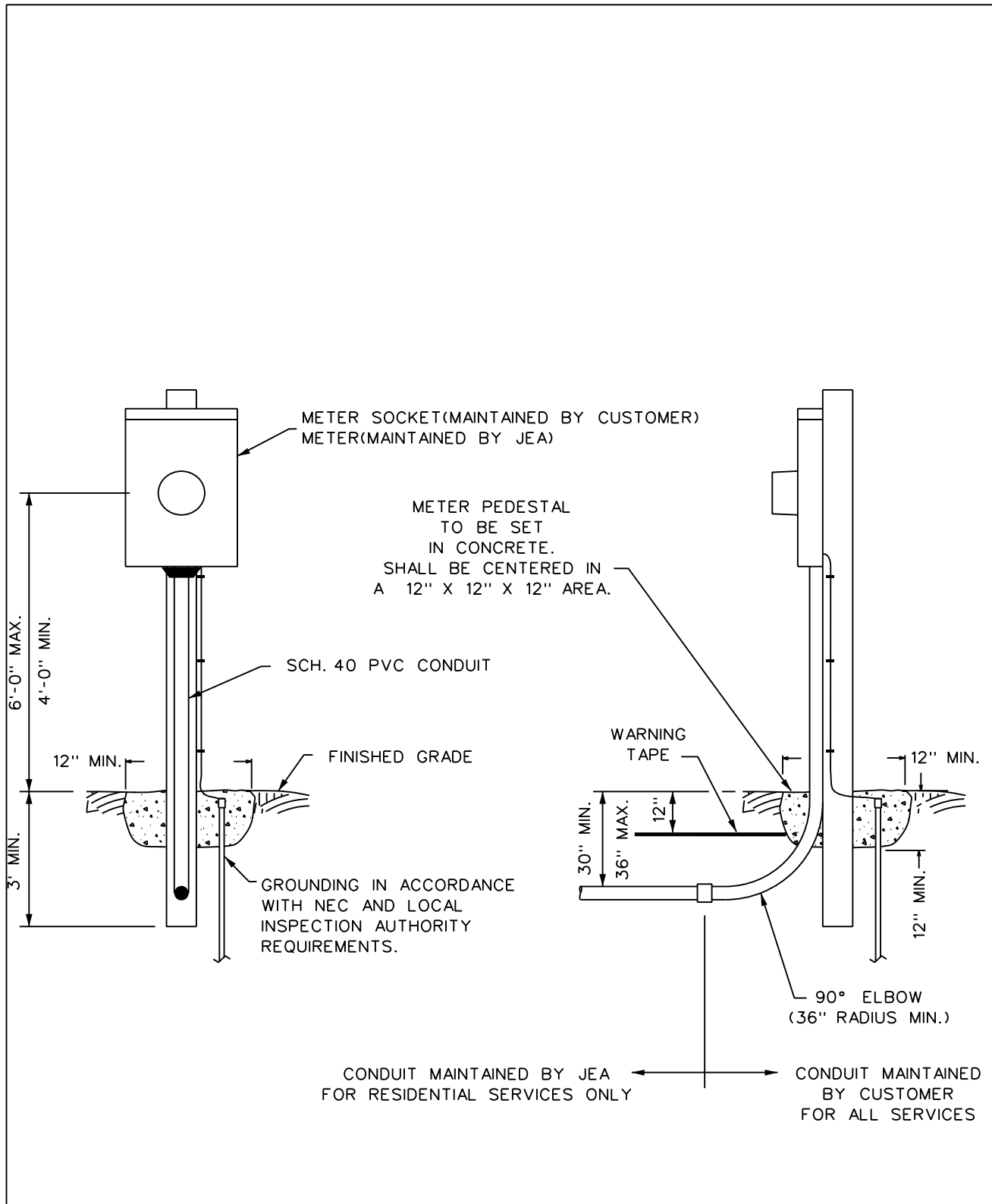

APP'D:	DRN: WILSON	METER PEDESTAL - UG SERVICE 1 PHASE & 3 PHASE ALL VOLTAGES SERVICE SIZE: 400 AMP MAXIMUM	
DATE : 11-15-95 09-01-07 10-24-96 4-5-99 10-8-01 1-18-04			
SCALE: NONE	JEA RULES AND REGULATIONS JACKSONVILLE, FLORIDA	FIGURE: 4.07	

NOTES :

1. METER PEDESTALS TO BE APPROVED BY JEA METER SERVICES OPERATIONS AND MAINTENANCE.
2. METER PEDESTALS TO BE SET IN CONCRETE; CENTERED IN MINIMUM 12" X 12" X 12".
3. UNDERGROUND METER PEDESTAL RESTRICTED TO:
 - SERVICES UNDERGROUND FROM POLE
 - COMMERCIAL UNDERGROUND SERVICES
 - UNDERGROUND MOBILE HOME SERVICES
 - WHERE METERS CANNOT BE ACCESSED FOR READING/REPAIR
4. RESIDENTIAL SERVICES FROM OVERHEAD POLE: REFERENCE FIGURE 4.04.
5. COMMERCIAL SERVICES FROM OVERHEAD POLE: REFERENCE FIGURES 4.04A & 4.04B.
6. COMMERCIAL UNDERGROUND CT SERVICES FROM PADMOUNTED TRANSFORMERS: REFERENCE FIGURE 4.03.
7. SERVICES LARGER THAN 300 AMPS: CONTACT JEA SERVICE ENGINEER.
8. POLY PULL WIRE IN CONDUIT REQUIRED FOR RESIDENTIAL SERVICES
9. PEDESTAL SUPPORT MATERIAL
 - 4" X 4" *2 GRADE SOUTHERN YELLOW PINE.
 - i. PRESSURE TREATED WITH C.C.A. TYPE C., 0.6 LBS. PER CU. FT. RETENTION. (TREATMENT LEVEL MUST BE STAMPED ON 4 X 4)
 - ii. SMOOTH ON ALL 4 SIDES
 - 3" GALVANIZED METAL POST WITH CAPPED TOP
 - 4" X4" REINFORCED CONCRETE (3000 PSI)

APP'D:	DRN: WILSON	METER PEDESTAL - UG SERVICE 1 PHASE & 3 PHASE ALL VOLTAGES SERVICE SIZE: 400 AMP MAXIMUM	
DATE :11-15-95 10-24-96 4-5-99 10-8-01 09-01-07		SCALE: NONE	JEA RULES AND REGULATIONS JACKSONVILLE , FLORIDA
		FIGURE:4.07	

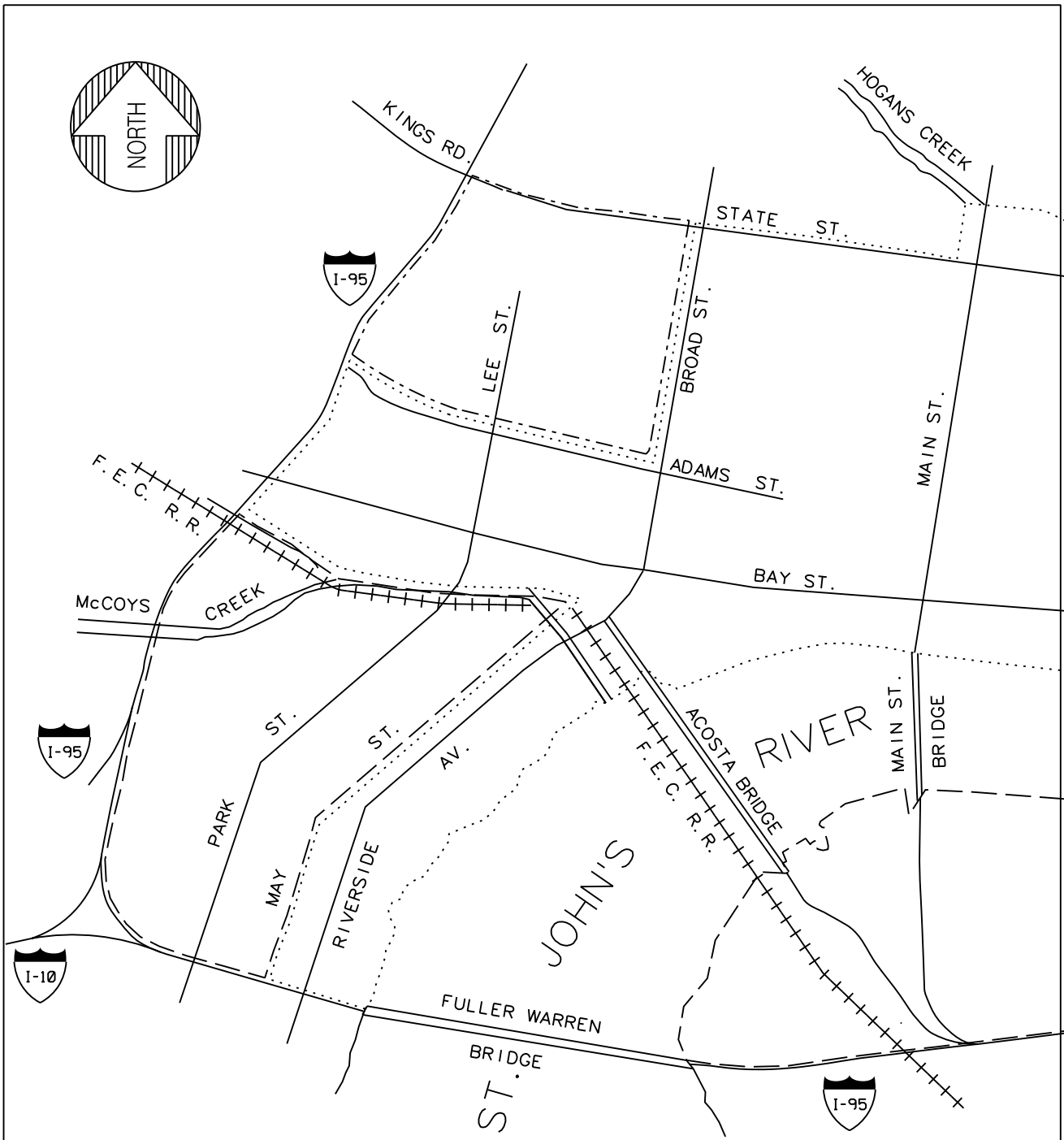

..... NETWORK SERVICE AREA
 - - - - - UNDERGROUND SERVICE AREA
 - · - · - CONTACT JEA ELECTRIC SERVICES

SEE FIGURE 5.01B

APP'D:	DRN: WILSON	DOWNTOWN SERVICE AREA BOUNDARY MAP	
DATE: 11-12-92 5-12-97 4-5-99 3-1-10			
SCALE:	NONE	JEA RULES AND REGULATIONS JACKSONVILLE, FLORIDA	FIGURE: 5.01A

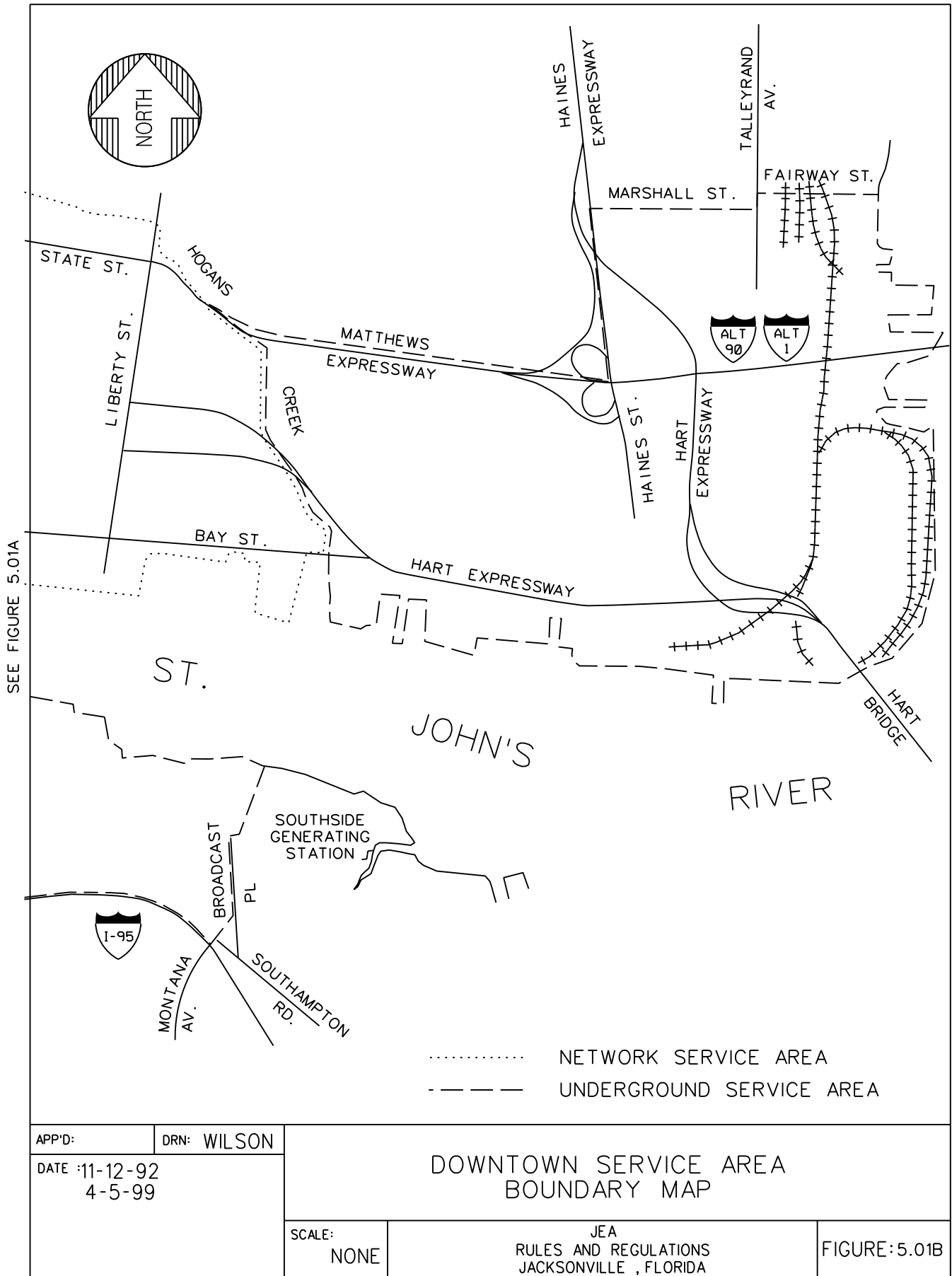

OH SERVICE NOT AVAILABLE FOR NEW PERMANENT SERVICES

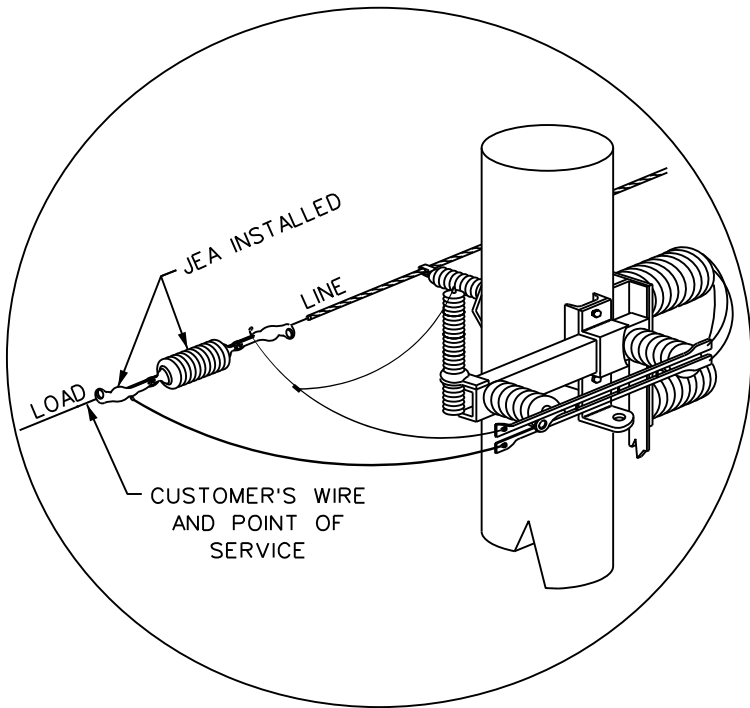

DETAIL

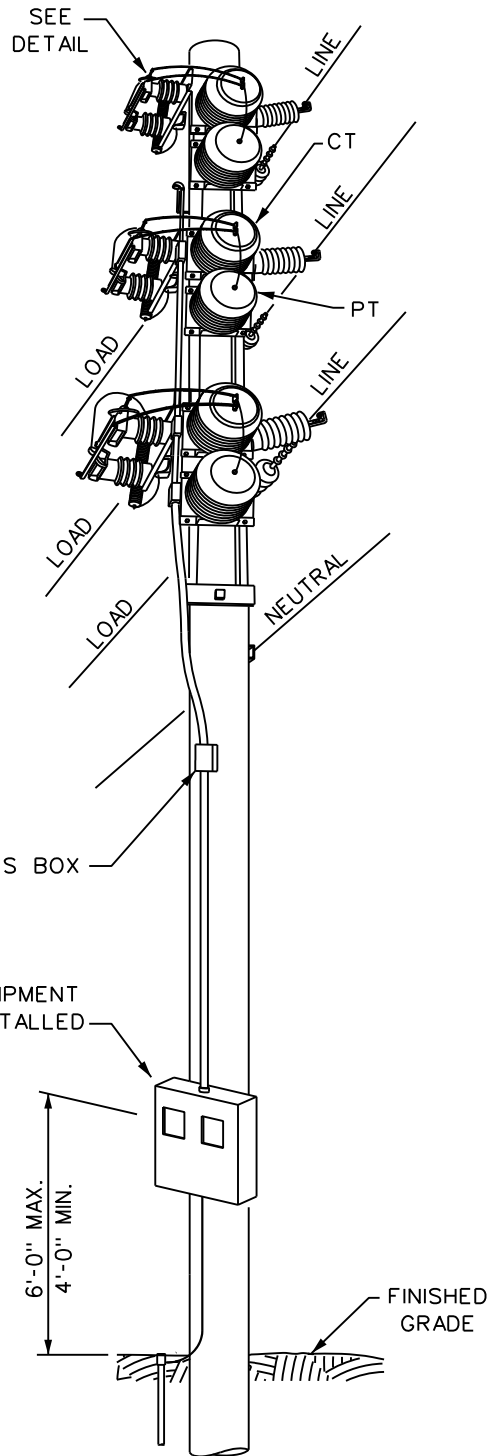

ALL METERING EQUIPMENT
FURNISHED AND INSTALLED
BY JEA

APP'D:	DRN: WILSON
DATE :	11-12-92 10-12-95 10-24-96 11-4-96 4-5-99

PRIMARY METERING INSTALLATION
EXISTING OH SERVICE

SCALE:
NONE

JEA
RULES AND REGULATIONS
JACKSONVILLE, FLORIDA

FIGURE: 6.01

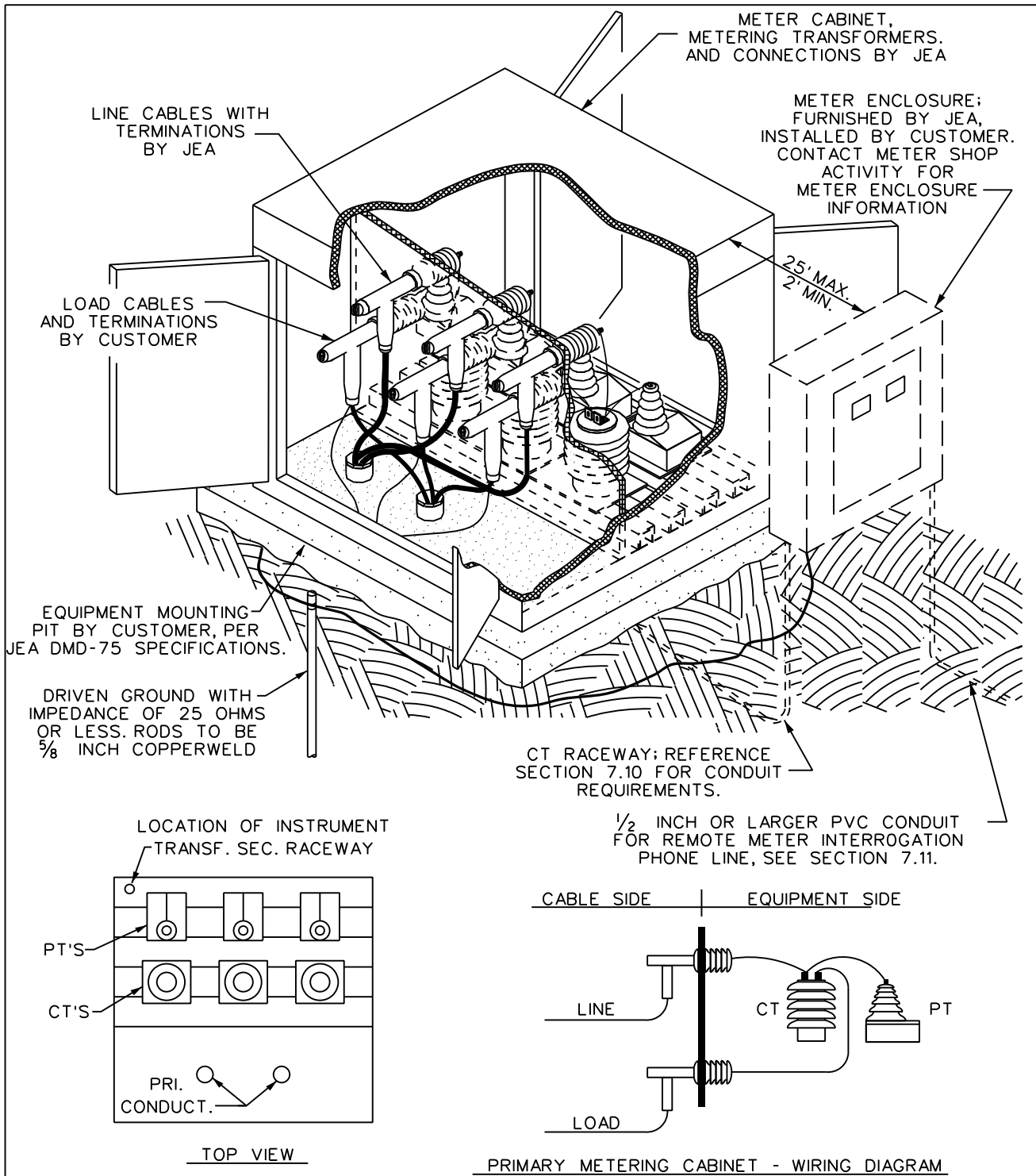

NOTE: ALL NEW PRIMARY METERING CABINET INSTALLATIONS WILL BE WIRED PER THE DIAGRAM ABOVE. IF AN EXISTING (OLD) CABINET NEEDS MAINTENANCE WHERE AN OUTAGE IS REQUIRED, IT SHOULD BE REWIRED AT THAT TIME.

APP'D:	DRN: WILSON	PRIMARY METERING PADMOUNTED INSTALLATION UG SERVICE	
DATE:	11-20-92 10-12-95 10-24-96 11-4-96 4-5-99		
SCALE: NONE		JEA RULES AND REGULATIONS JACKSONVILLE, FLORIDA	FIGURE: 6.02

OH SERVICE NOT AVAILABLE FOR NEW PERMANENT SERVICES

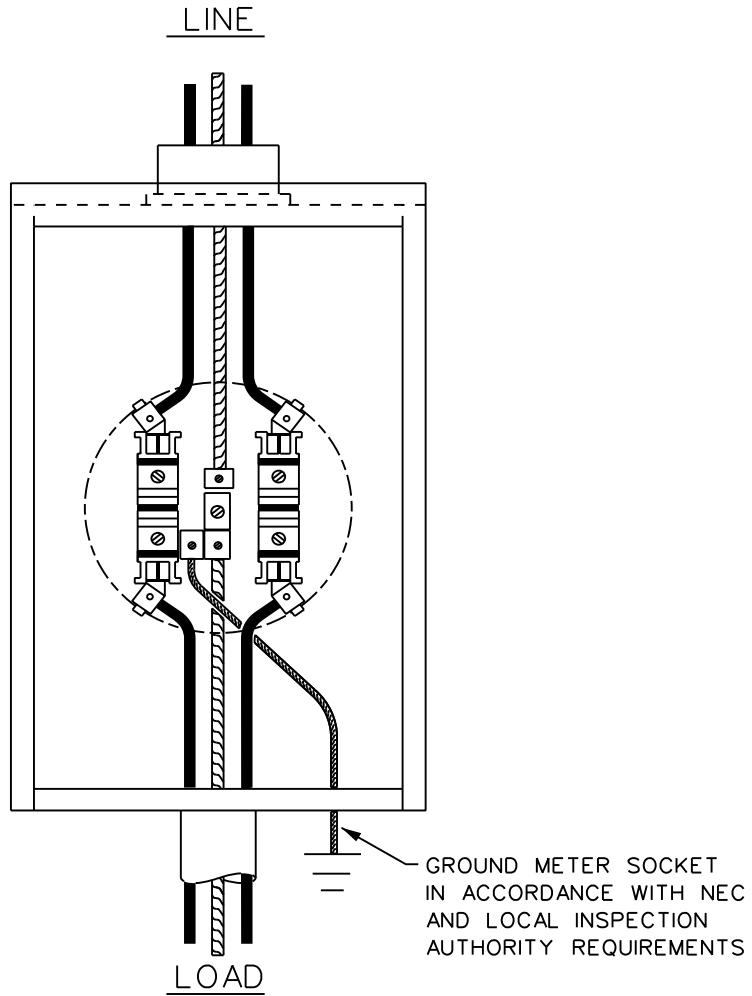

NOTE: NOT AVAILABLE FOR PURCHASE FROM JEA

REFERENCE SECTION 7.04 FOR METER SOCKET SPECIFICATIONS.

APP'D:	DRN: WILSON	SELF-CONTAINED METER SOCKET - EXISTING OH SERVICE	
DATE :		1 PHASE 3 WIRE - SERVICE SIZE:	
11-12-92		200 AMP MAXIMUM 120/240V & 150 AMP MAXIMUM 240/480V	
10-12-95			
10-24-96			
4-5-99		SCALE:	JEA
		NONE	RULES AND REGULATIONS
			JACKSONVILLE , FLORIDA
			FIGURE: 7.01

OH SERVICE NOT AVAILABLE FOR NEW PERMANENT SERVICES

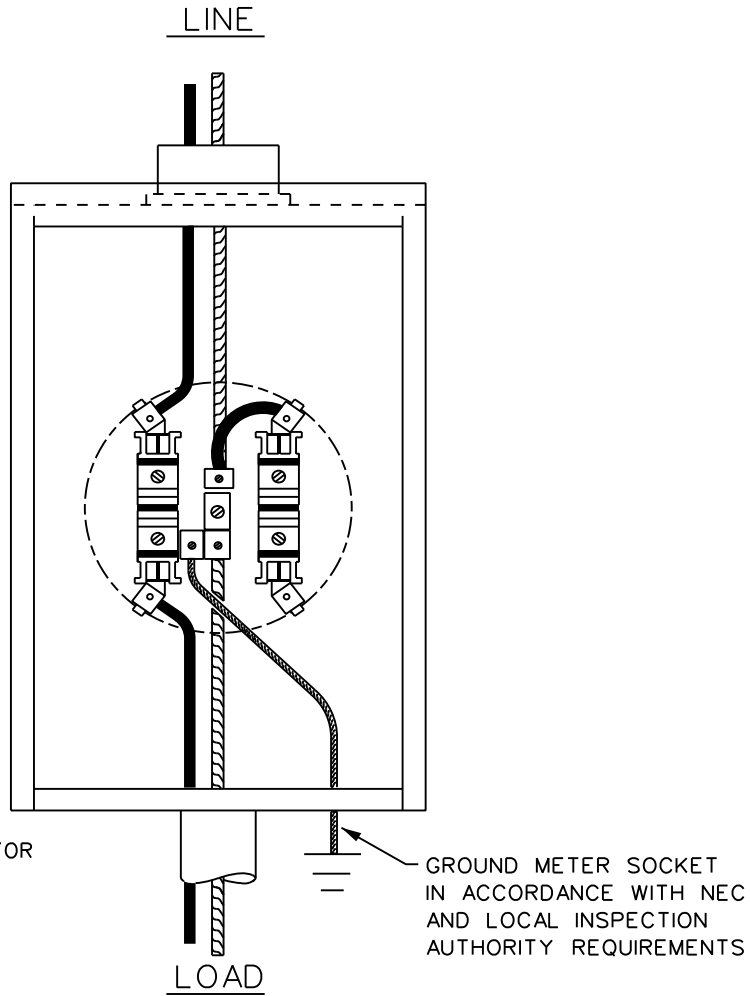

WIRING:
 LEFT LINE SIDE -
 120V SERVICE CONDUCTOR
 LEFT LOAD SIDE -
 120V SERVICE ENTRANCE CONDUCTOR
 NEUTRAL -
 STRAIGHT TO THE MIDDLE LUG
 RIGHT LINE SIDE -
 JUMPERED TO NEUTRAL
 RIGHT LOAD SIDE -
 NO CONNECTION

GROUND METER SOCKET
 IN ACCORDANCE WITH NEC
 AND LOCAL INSPECTION
 AUTHORITY REQUIREMENTS

NOTE: NOT AVAILABLE FOR PURCHASE FROM JEA

REFERENCE SECTION 7.04 FOR METER SOCKET SPECIFICATIONS.

APP'D:	DRN: ACS	SELF-CONTAINED METER SOCKET - EXISTING OH SERVICE 1 PHASE 2 WIRE - SERVICE SIZE: 100 AMP MAXIMUM 120V	
DATE : 10-27-20			
SCALE:	NONE	JEA RULES AND REGULATIONS JACKSONVILLE , FLORIDA	FIGURE:7.01A

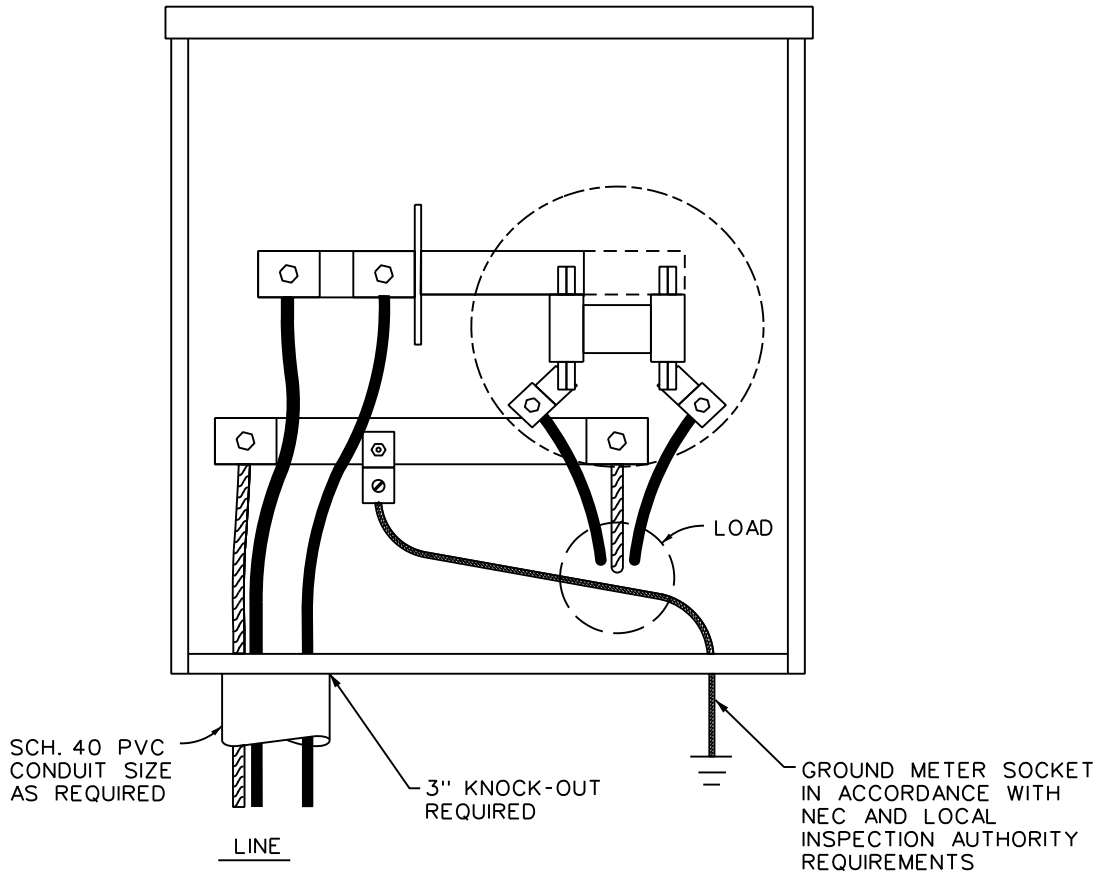

* FIFTH TERMINAL REQUIRED FOR 120/208V. REFERENCE FIGURE 7.04
 FOR TERMINAL LOCATION AND SECTION 7.04 FOR METER SOCKET SPECIFICATIONS.

NOTE: NOT AVAILABLE FOR PURCHASE FROM JEA.

APP'D:	DRN: WILSON	SELF-CONTAINED METER SOCKET - UG SERVICE 1 PHASE 3 WIRE 120/240V SERVICE SIZE: 200 AMP MAXIMUM		
DATE :				
11-12-92 10-12-95 10-24-96 4-5-99		SCALE: NONE	JEA RULES AND REGULATIONS JACKSONVILLE , FLORIDA	FIGURE:7.02

OH SERVICE NOT AVAILABLE FOR NEW PERMANENT SERVICES

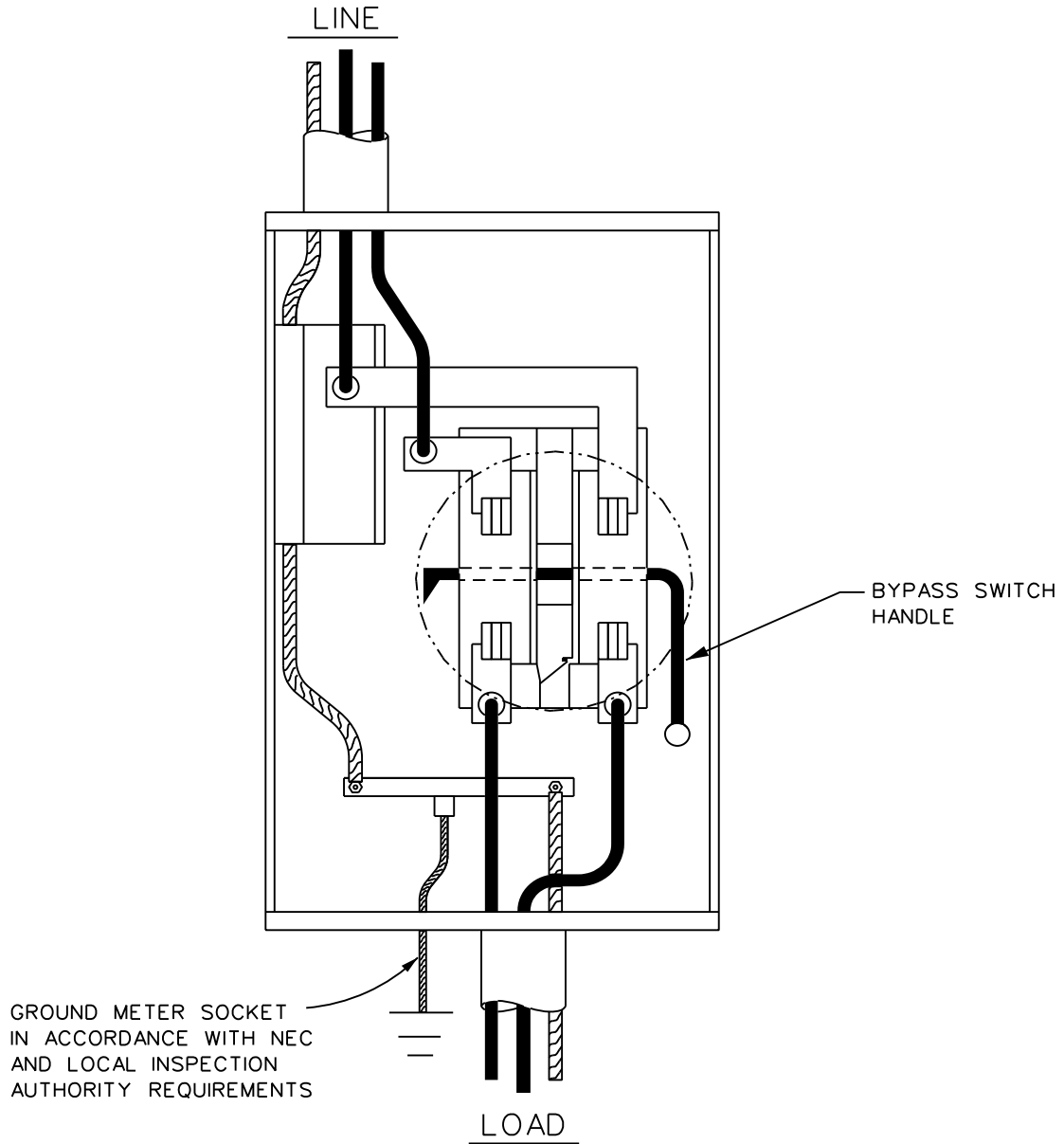

NOTE: NOT AVAILABLE FOR PURCHASE FROM JEA.

REFERENCE SECTION 7.04 FOR METER SOCKET SPECIFICATIONS.

APP'D:	DRN: WILSON	SELF-CONTAINED METER SOCKET - UG & EXISTING OH SERVICE	
DATE: 09-26-94 10-12-95 10-24-96 11-4-96 4-5-99		1 PHASE 3 WIRE 120/240V	
		SERVICE SIZE: ABOVE 200 AMPS, 400 AMP MAXIMUM	
SCALE:	NONE	JEA RULES AND REGULATIONS JACKSONVILLE, FLORIDA	FIGURE: 7.03

OH SERVICE NOT AVAILABLE FOR NEW PERMANENT SERVICES

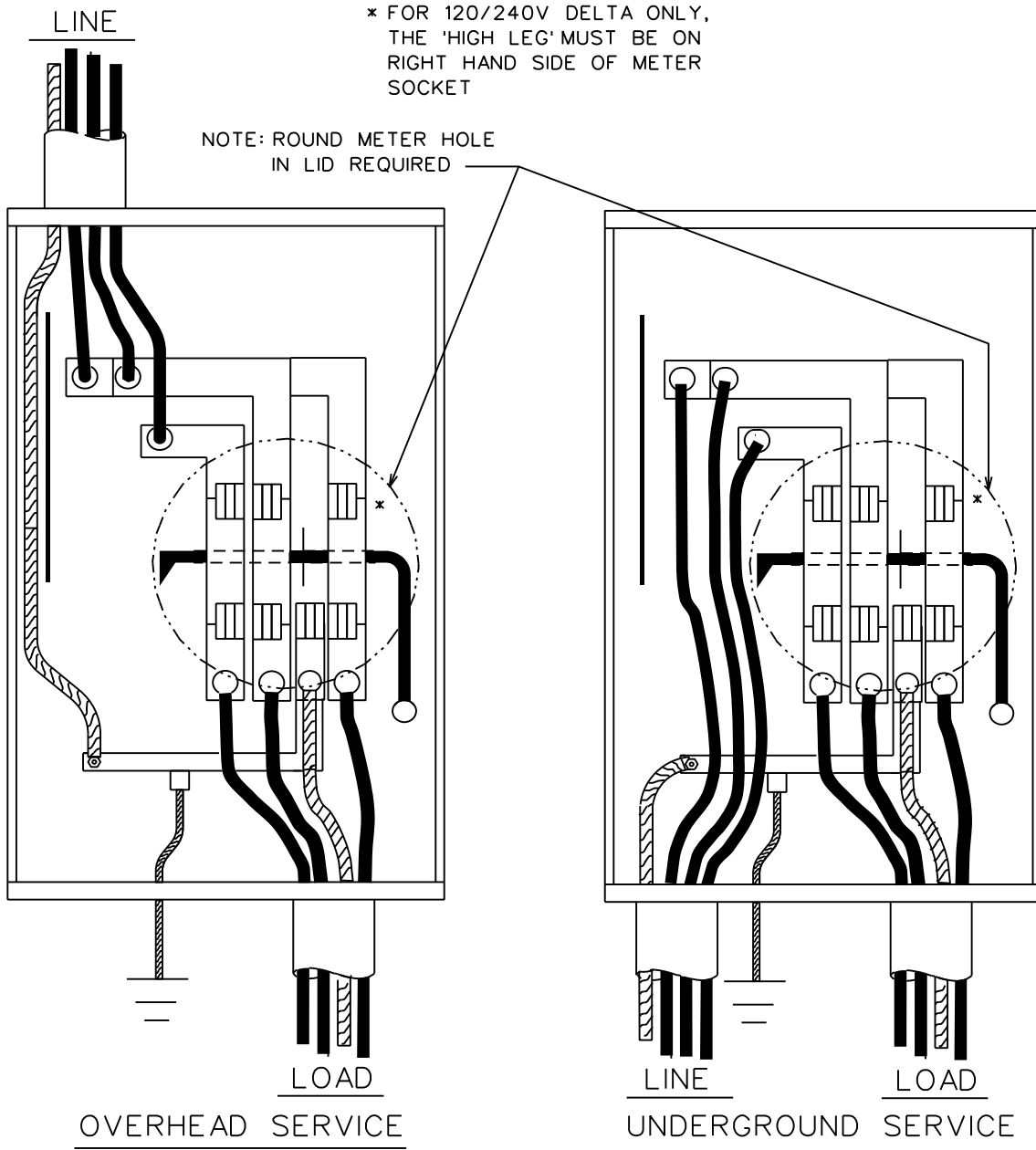

NOTE: NOT AVAILABLE FOR PURCHASE FROM JEA.
REFERENCE SECTION 7.04 FOR METER SOCKET SPECIFICATIONS.

GROUND METER SOCKET
IN ACCORDANCE WITH NEC
AND LOCAL INSPECTION
AUTHORITY REQUIREMENTS

APP'D:	DRN: SIMMONS	SELF-CONTAINED METER SOCKET - UG & EXISTING OH SERVICE	
DATE : 4-6-99		3 PHASE 4 WIRE ALL VOLTAGES	
		SERVICE SIZE: ABOVE 200 AMPS, 400 AMP MAXIMUM	
SCALE:	NONE	JEA RULES AND REGULATIONS JACKSONVILLE , FLORIDA	FIGURE: 7.03A

OH SERVICE NOT AVAILABLE FOR NEW PERMANENT SERVICES

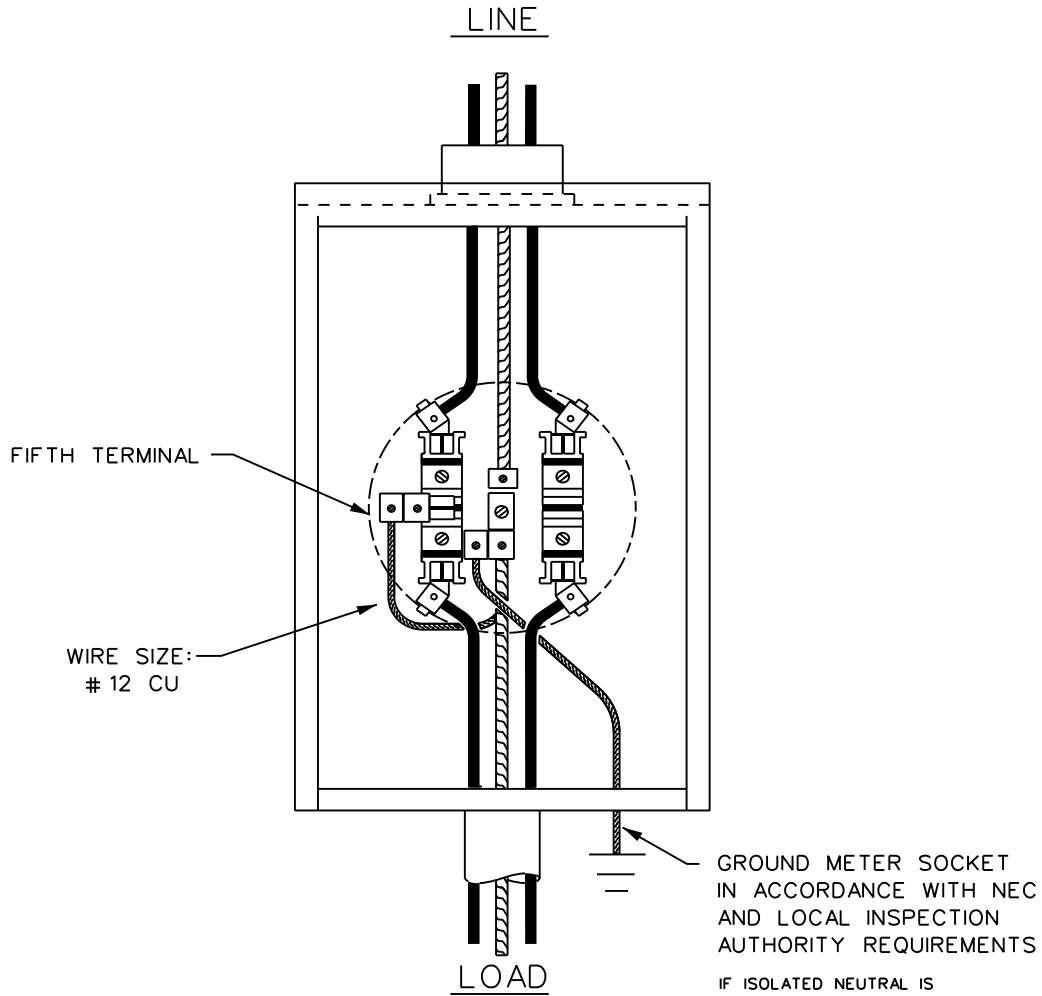

IF ISOLATED NEUTRAL IS REQUIRED AN ISOLATION KIT MUST BE INSTALLED TO PROVIDE A NEUTRAL RETURN FOR THE METER. (THIS WOULD BE TYPICAL WITH METER ON LOAD SIDE OF THE SERVICE DISCONNECTING MEANS)

METER CAN SHALL BE BONDED TO THE SYSTEM GROUNDING ELECTRODE.

NOTE: NOT AVAILABLE FOR PURCHASE FROM JEA

REFERENCE SECTION 7.04 FOR METER SOCKET SPECIFICATIONS.

APP'D:	DRN: WILSON	SELF-CONTAINED METER SOCKET - EXISTING OH SERVICE	
DATE : 09-23-94 10-12-95 10-24-96 4-6-99 12-10-20		1 PHASE 3 WIRE 120/208V SERVICE SIZE: 200 AMP MAXIMUM	
SCALE:	NONE	JEA RULES AND REGULATIONS JACKSONVILLE , FLORIDA	FIGURE: 7.04

OH SERVICE NOT AVAILABLE FOR NEW PERMANENT SERVICES

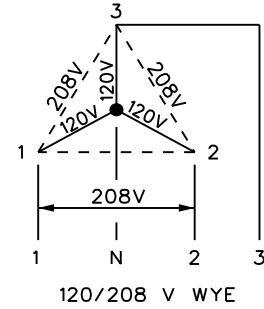
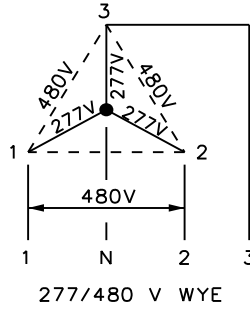
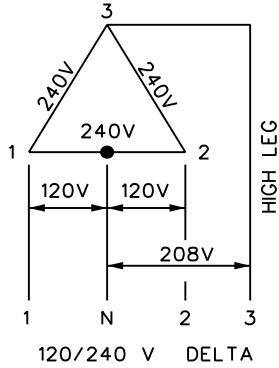

IF ISOLATED NEUTRAL IS REQUIRED AN ISOLATION KIT MUST BE INSTALLED TO PROVIDE A NEUTRAL RETURN FOR THE METER. (THIS WOULD BE TYPICAL WITH METER ON LOAD SIDE OF THE SERVICE DISCONNECTING MEANS)

METER CAN SHALL BE BONDED TO THE SYSTEM GROUNDING ELECTRODE.

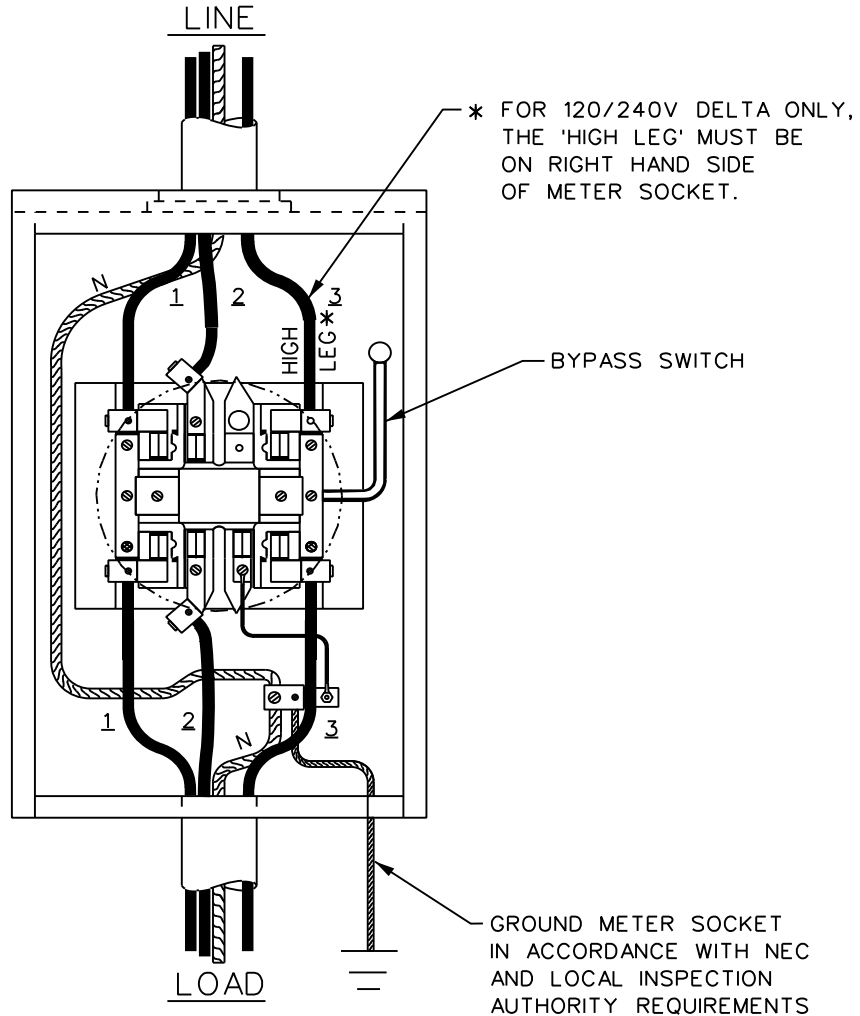
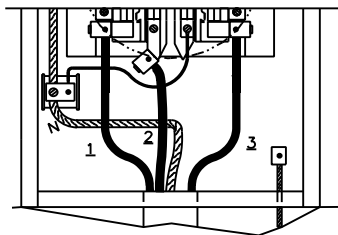

NOTE: NOT AVAILABLE FOR PURCHASE FROM JEA.

REFERENCE SECTION 7.04 FOR METER SOCKET SPECIFICATIONS.

APP'D:	DRN: WILSON	SELF-CONTAINED METER SOCKET - UG & EXISTING OH SERVICE	
DATE : 11-12-92 10-12-95 10-24-96 4-6-99 11-30-20		3 PHASE 4 WIRE ALL VOLTAGES SERVICE SIZE: 200 AMP MAXIMUM	
SCALE:	NONE	JEA RULES AND REGULATIONS JACKSONVILLE, FLORIDA	FIGURE: 7.05

NOT AVAILABLE FOR NEW SERVICES

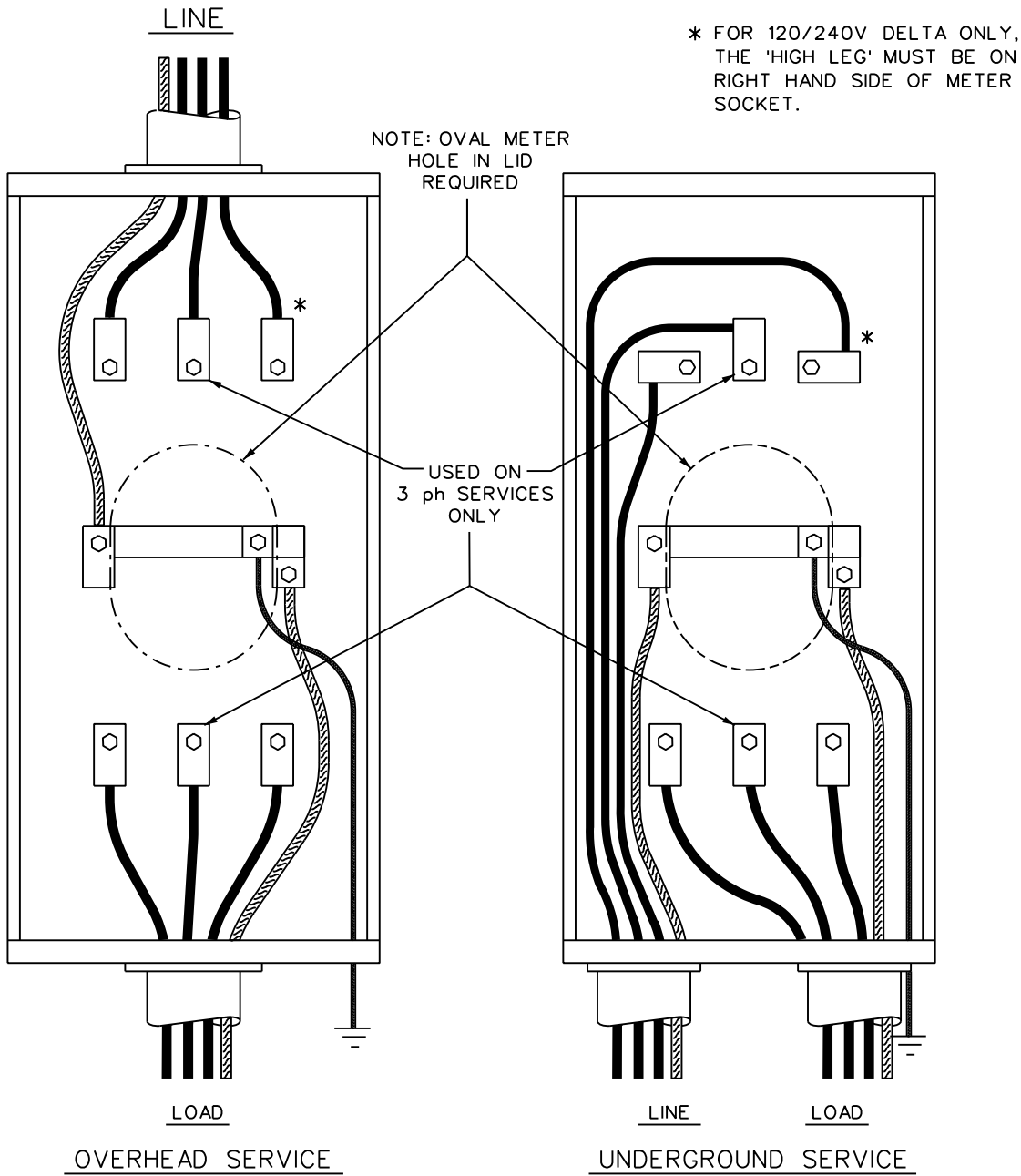

GROUND METER SOCKET IN ACCORDANCE WITH NEC AND LOCAL INSPECTION AUTHORITY REQUIREMENTS.

APP'D:	DRN: WILSON
DATE :	11-14-95 10-24-96 4-6-99 09-01-07

SELF-CONTAINED (K BASE) METER SOCKET UG & EXISTING OH SERVICE 1 PHASE AND 3 PHASE ALL VOLTAGES SERVICE SIZE: ABOVE 400 AMPS, 600 AMP MAXIMUM	
SCALE: NONE	JEA RULES AND REGULATIONS JACKSONVILLE, FLORIDA
FIGURE: 7.05A	

OH SERVICE NOT AVAILABLE FOR NEW PERMANENT SERVICES

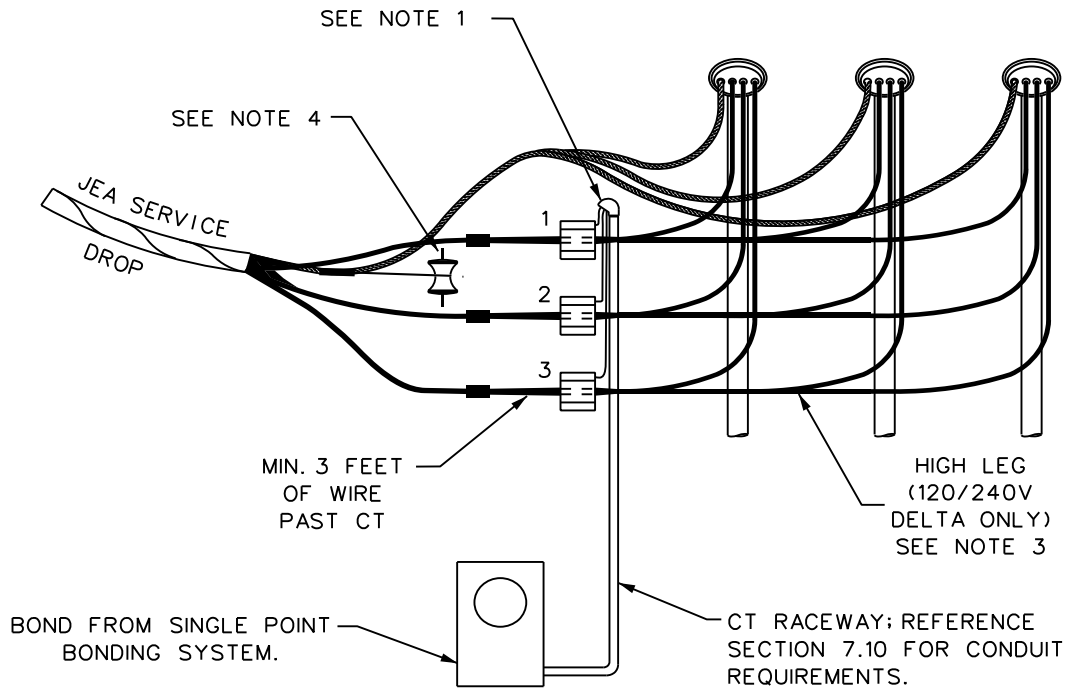

PROFILE VIEW

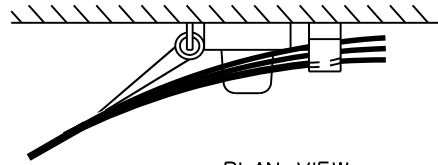

PLAN VIEW

NOTES:

1. SECONDARY RACEWAY WEATHERHEAD MOUNTED MINIMUM 6" ABOVE CT #1.
2. CT'S MUST BE SOLIDLY MOUNTED.
3. 3 PHASE 120/240V: HIGH LEG INSTALLED THROUGH CT #3; MARKED WITH ORANGE COLOR CODING.
4. MINIMUM POINT OF ATTACHMENT: REFERENCE TABLE 3A.
5. HORIZONTALLY MOUNTED CT'S SHALL BE NUMBERED 1-2-3 LEFT TO RIGHT. REFERENCE FIGURE 7.06A.

APP'D:	DRN: WILSON	CURRENT TRANSFORMER (WALL MOUNTED) EXISTING OH SERVICE 3 PHASE ALL VOLTAGES SERVICE SIZE: ABOVE 400 AMPS, 800 AMP MAXIMUM	
DATE : 11-12-92 10-12-95 10-24-96 4-6-99 09-01-07	SCALE: NONE	JEA RULES AND REGULATIONS JACKSONVILLE , FLORIDA	FIGURE: 7.06

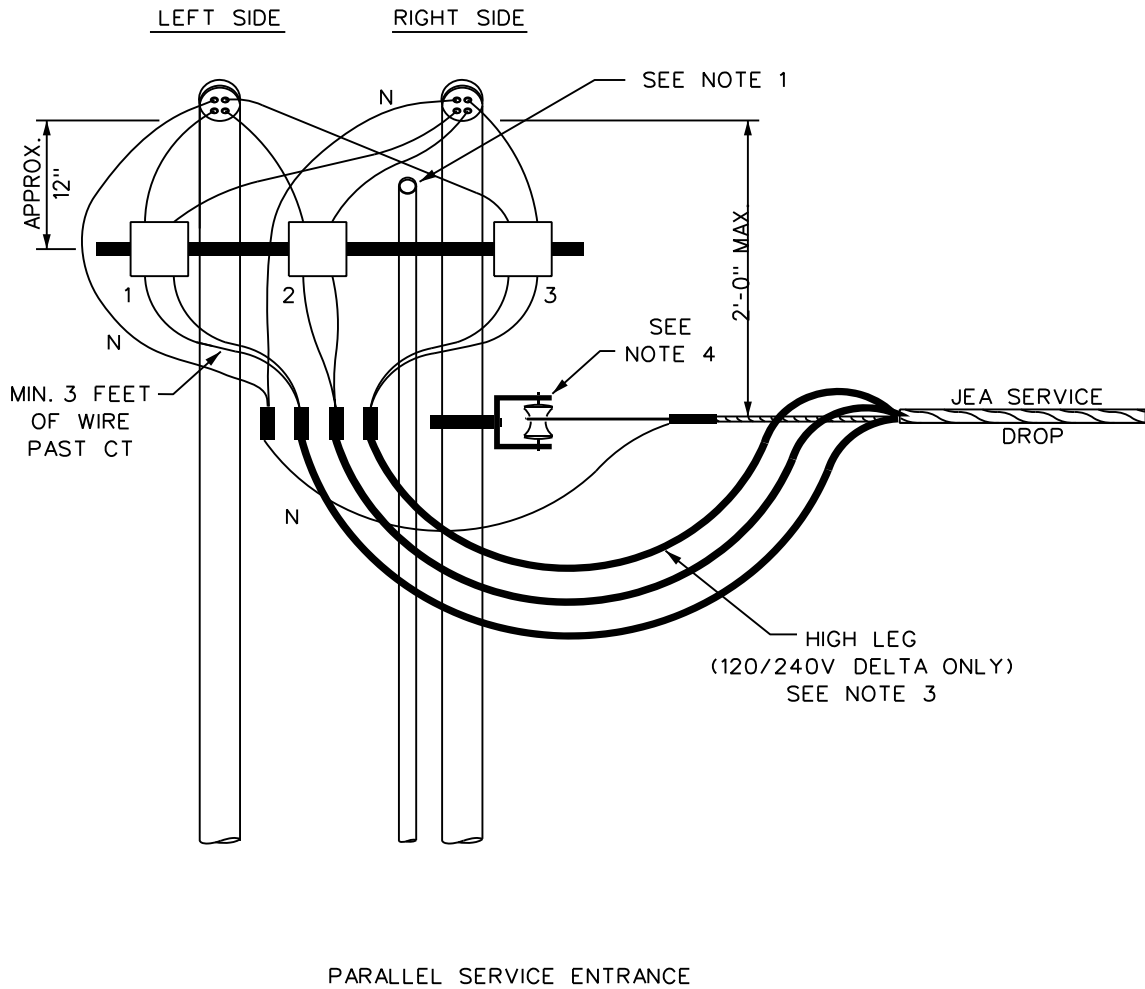

REFERENCE NOTES FIGURE 7.06

APP'D:	DRN: WILSON	CURRENT TRANSFORMER (HORIZONTAL MAST MOUNTED)	
DATE : 11-12-92 10-24-96 4-6-99 09-01-07		EXISTING OH SERVICE - 3 PHASE ALL VOLTAGES	
		SERVICE SIZE: ABOVE 400 AMPS, 800 AMP MAXIMUM	
SCALE:	NONE	JEA RULES AND REGULATIONS JACKSONVILLE , FLORIDA	FIGURE:7.06A

OH SERVICE NOT AVAILABLE FOR NEW PERMANENT SERVICES

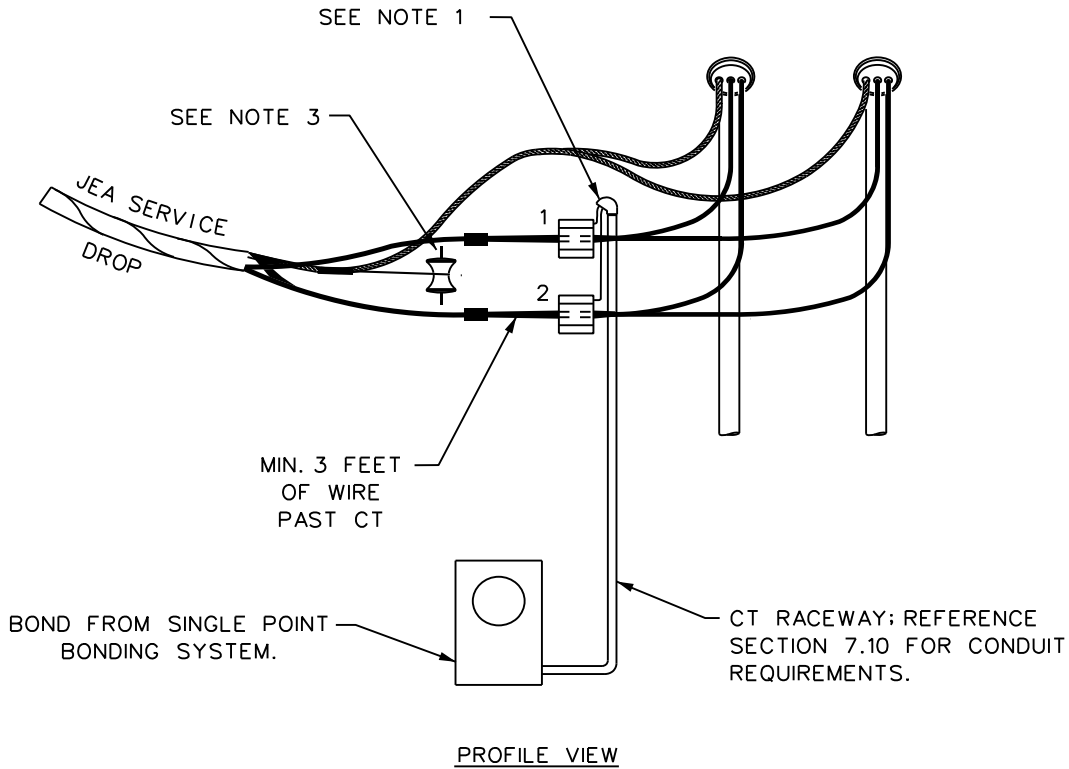

PROFILE VIEW

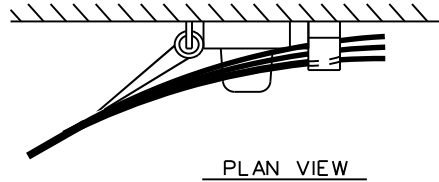

PLAN VIEW

NOTES:

1. SECONDARY RACEWAY WEATHERHEAD MOUNTED MINIMUM 6" ABOVE CT* 1.
2. CT'S MUST BE SOLIDLY MOUNTED.
3. MINIMUM POINT OF ATTACHMENT: REFERENCE TABLE 3A.
4. HORIZONTALLY MOUNTED CT'S SHALL BE NUMBERED 1-2 LEFT TO RIGHT. REFERENCE FIGURE 7.06A.

APP'D:	DRN: WILSON	CURRENT TRANSFORMER (WALL MOUNTED) EXISTING OH SERVICE 1 PHASE 120/240V SERVICE SIZE: ABOVE 400 AMPS, 800 AMP MAXIMUM	
DATE : 11-12-92 10-12-95 10-24-96 4-9-99 09-01-07			
SCALE:	NONE	JEA RULES AND REGULATIONS JACKSONVILLE , FLORIDA	FIGURE:7.07

OH SERVICE NOT AVAILABLE FOR NEW PERMANENT SERVICES

LEGEND :

- A ph
- B ph
- C ph
- - - - Neutral

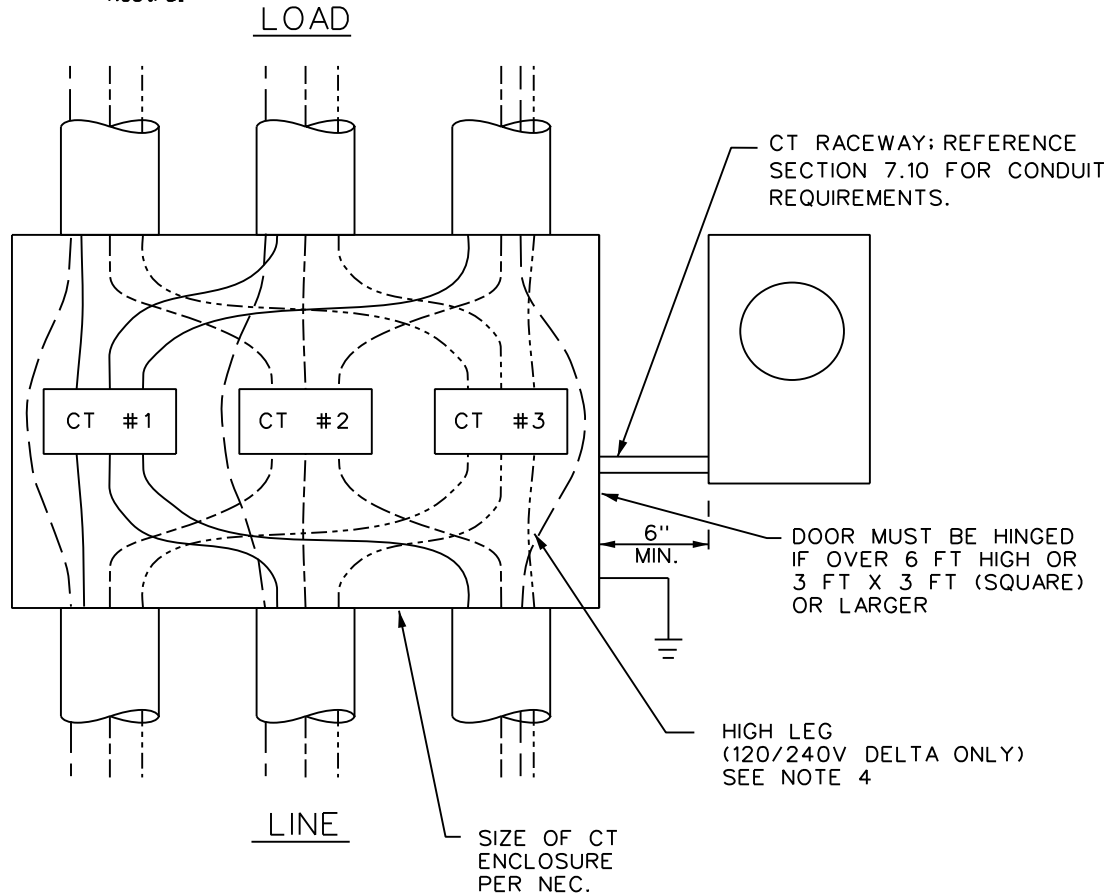

NOTES:

1. CT'S, CT CABINET AND METER SOCKET/ENCLOSURE SHALL BE GROUNDED IN ACCORDANCE WITH THE NEC AND LOCAL INSPECTION AUTHORITY REQUIREMENTS.
2. CABINET SHALL BE CAPABLE OF BEING SEALED AND/OR LOCKED BY THE JEA METER SHOP ACTIVITY.
3. CONDUITS ENTERING CT CABINET FROM POINT OF SERVICE SHALL BE MARKED "LINE" AND CONDUITS LEAVING CT CABINET TO CUSTOMER SERVICE EQUIPMENT "LOAD".
4. 3 PHASE 120/240V: HIGH LEG INSTALLED THROUGH CT #3; MARKED WITH ORANGE COLOR CODING.
5. 1 PHASE 120/240V: OMIT CT #3. REFERENCE FIGURE 7.07.
6. CT'S MUST BE SOLIDLY MOUNTED AND BONDED FROM SINGLE POINT BONDING SYSTEM.

APP'D:	DRN: WILSON	CURRENT TRANSFORMER (CABINET MOUNTED) UG SERVICE - 1 PHASE & 3 PHASE ALL VOLTAGES SERVICE SIZE: ABOVE 400 AMPS	
DATE :11-12-92 10-12-95 10-24-96 4-6-99 09-01-07		SCALE: NONE	JEA RULES AND REGULATIONS JACKSONVILLE, FLORIDA
			FIGURE: 7.08

OH SERVICE NOT AVAILABLE FOR NEW PERMANENT SERVICES

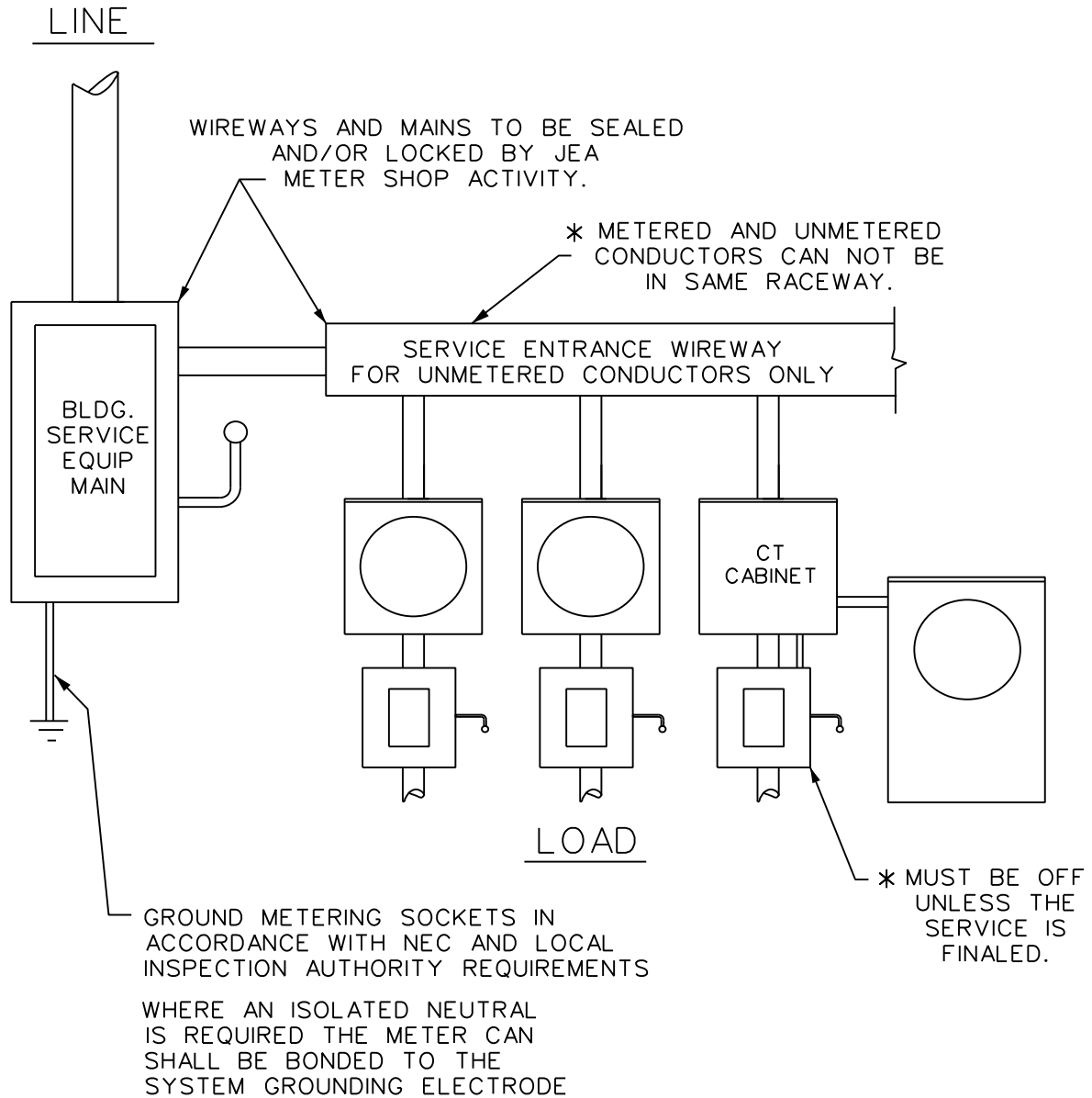

APP'D:	DRN: GERRISH
DATE :	11-12-92 10-12-95 10-24-96 4-6-99 08-27-20

GROUP METER SOCKET INSTALLATION
UG & EXISTING OH SERVICE
BEHIND BUILDING'S SERVICE EQUIPMENT MAIN

SCALE:
NONE

JEA
RULES AND REGULATIONS
JACKSONVILLE, FLORIDA

FIGURE: 7.09

OH SERVICE NOT AVAILABLE FOR NEW PERMANENT SERVICES

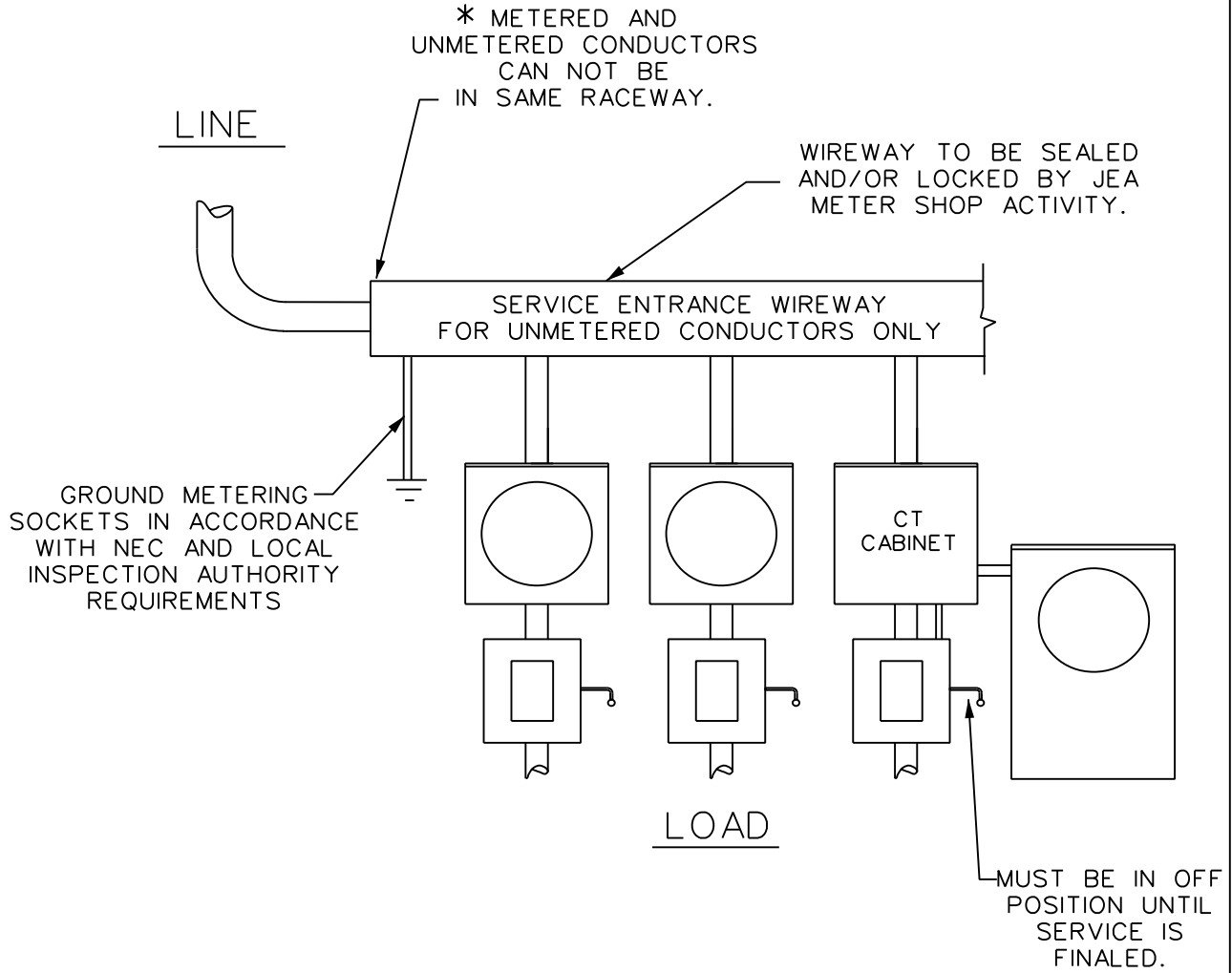

APP'D:	DRN: GERRISH	GROUP METER SOCKET INSTALLATION UG & EXISTING OH SERVICE 2 TO 6 METERS	
DATE: 11-12-92 10-12-95 10-24-96 4-6-99	SCALE: NONE		

OH SERVICE NOT AVAILABLE FOR NEW PERMANENT SERVICES

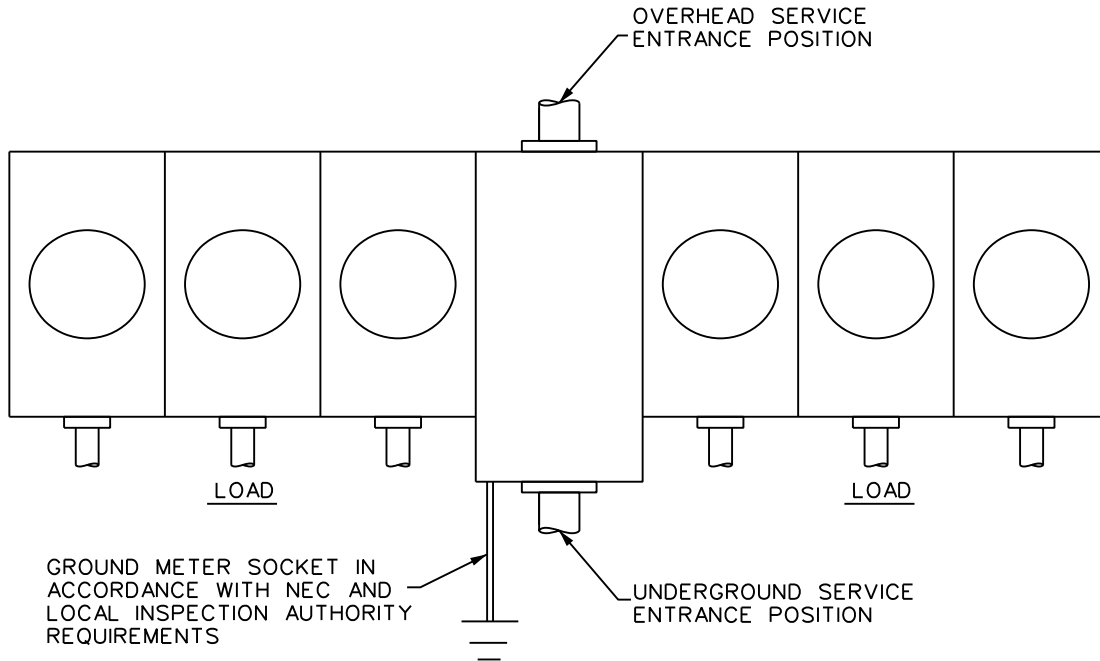

NOTE :

1. NOT ALLOWED ON COMMERCIAL SERVICES BY CITY OF JACKSONVILLE ELECTRICAL INSPECTION. SEE FIGURE 7.09.
2. METER SOCKETS NOT AVAILABLE FOR PURCHASE FROM JEA.
3. REFERENCE SECTION 7.04 FOR METER SOCKET SPECIFICATIONS.

APP'D:	DRN: WILSON	GROUP METER SOCKET INSTALLATION UG & EXISTING OH SERVICE - 2 TO 6 METERS 1 PHASE 120/240V SERVICE SIZE: 200AMP MAXIMUM	
DATE 11-12-92 10-24-96 4-6-99			
SCALE:	NONE	JEA RULES AND REGULATIONS JACKSONVILLE , FLORIDA	FIGURE: 7.11

OH SERVICE NOT AVAILABLE FOR NEW PERMANENT SERVICES

NOTES :

1. METER CENTER SHALL BE APPROVED BY JEA CUSTOMER FIELD AND METER SERVICES PRIOR TO INSTALLATION. (SEE SECTION 7.11)
2. DIMENSIONS ARE TO CENTERLINE OF METER.
3. EACH METER SOCKET SHALL HAVE AN INDIVIDUAL FACE.
4. PERMANENT IDENTIFICATION IS REQUIRED ON THE INSIDE OF EACH METER SOCKET AS WELL AS THE METER SOCKET FACE PLATE.
5. EACH METER SOCKET SHALL BE GROUNDED IN ACCORDANCE WITH THE NEC AND LOCAL INSPECTION AUTHORITY REQUIREMENTS.
6. METER SOCKETS FOR 120/208V SINGLE PHASE SERVICES SHALL BE EQUIPPED WITH A FIFTH TERMINAL POSITION. SEE FIGURE 7.04.

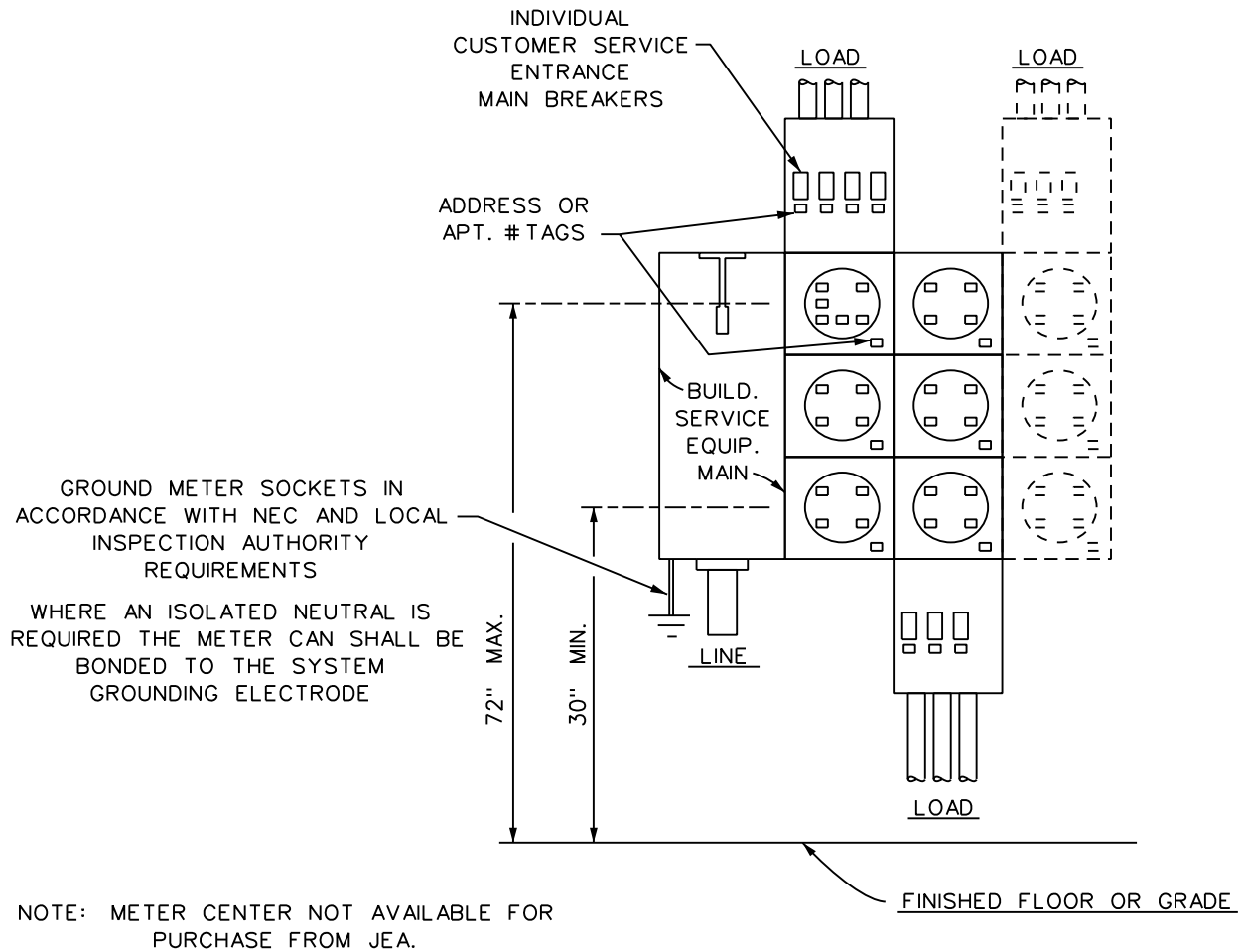

APP'D:	DRN: WILSON	PREWIRED METER CENTER INSTALLATION UG & EXISTING OH SERVICE	
DATE : 11-12-92 01-01-17 10-12-95 12-01-20 10-24-96 4-6-99 1-18-04			
SCALE: NONE	JEA RULES AND REGULATIONS JACKSONVILLE , FLORIDA	FIGURE: 7.12	

NOTES :

1. METER CENTER SHALL BE APPROVED BY JEA RESIDENTIAL METER SERVICES SECTION PRIOR TO INSTALLATION.
2. INSTALL 2' X 2' X 3/4" PLYWOOD AT 6' ABOVE FINISH FLOOR
3. INSTALL A DEDICATED NEMA 5-15R DUPLEX RECPT WITHIN 4' OF PLYWOOD.
4. INSTALL 1-1/2" PVC CONDUIT TO EXTERIOR OF BUILDING
5. TERMINATE THE 1-1/2" CONDUIT WITH A 6" X 6" X 4"D PVC BOX ON THE EXTERIOR OF THE BUILDING

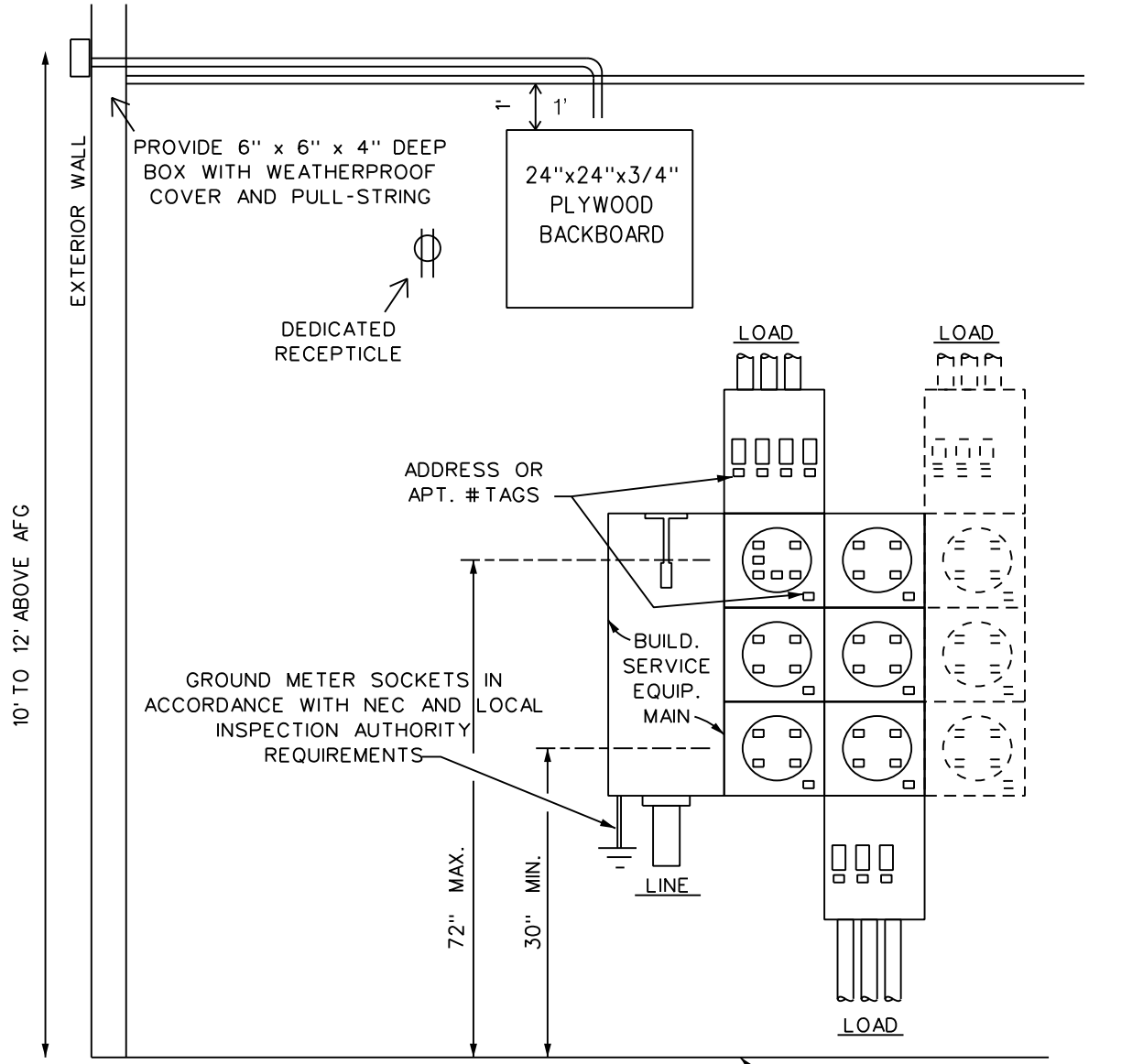

NOTE: METER CENTER NOT AVAILABLE FOR PURCHASE FROM JEA.

APP'D: _____
DATE 07-10-20

DRN: WILSON

JEA SMART METER COMMUNICATION CONDUIT
TYP. ALL INTERIOR METER LOCATIONS

SCALE:
NONE

JEA
RULES AND REGULATIONS
JACKSONVILLE, FLORIDA

FIGURE:7.12A

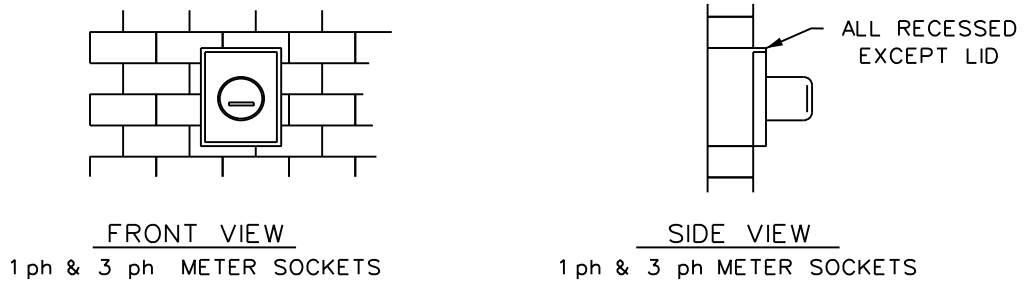
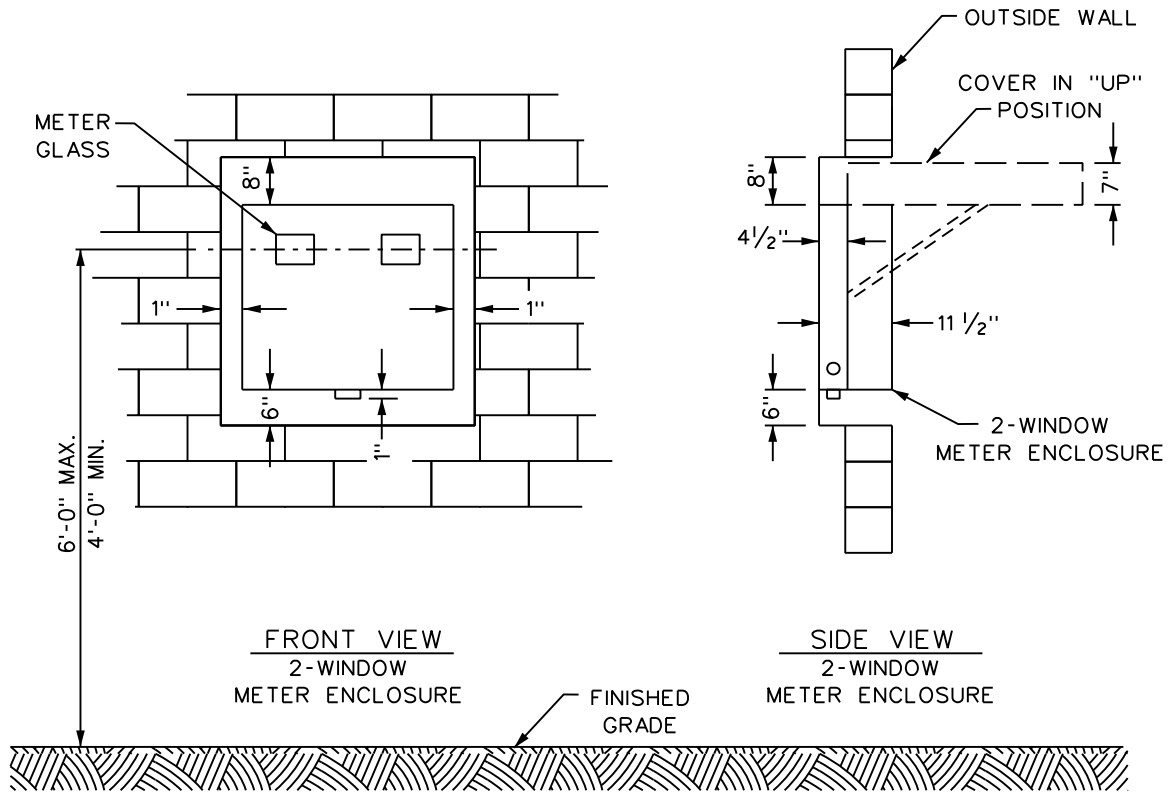

NOTES:

1. METER SOCKETS/ENCLOSURES INSTALLED ON WALLS FACING THE PUBLIC SIDEWALK MUST BE RECESSED FLUSH WITH THE WALL (NO PROJECTION OVER THE SIDEWALK).
2. CT RACEWAY; REFERENCE SECTION 7.10 FOR CONDUIT REQUIREMENTS.
3. METER SOCKETS/ENCLOSURES SHALL BE GROUNDED IN ACCORDANCE WITH THE NEC AND LOCAL INSPECTION AUTHORITY REQUIREMENTS.
4. MINIMUM 3" SPACING REQUIRED BETWEEN MULTIPLE METER SOCKETS/ENCLOSURES.

APP'D: DRN: WILSON

DATE : 11-20-92
10-12-95
10-24-96
4-6-99

RECESSED METER SOCKET/
ENCLOSURE INSTALLATION

SCALE:
NONE

JEA
RULES AND REGULATIONS
JACKSONVILLE, FLORIDA

FIGURE: 7.13

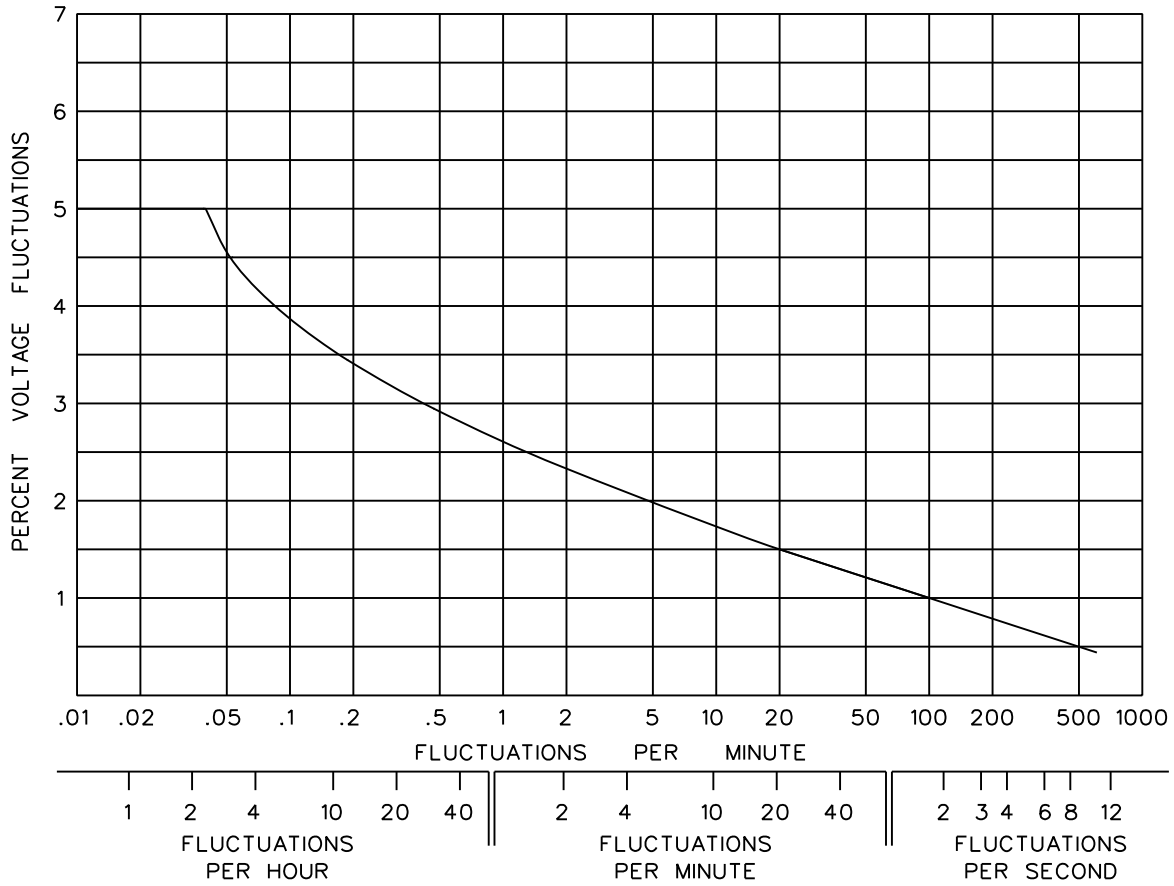

THE CUSTOMER SHALL NOT BE ALLOWED TO IMPOSE VOLTAGE FLUCTUATIONS ABOVE FIVE (5) PERCENT ON THE JEA SYSTEM EXCEPT UNDER EXTREME CIRCUMSTANCES. FOR APPROVAL, CONTACT THE JEA DISTRIBUTION PLANNING AND ANALYSIS SECTION.

APP'D: _____ DRN: WILSON
DATE : 11-12-92
4-6-99

MAXIMUM ALLOWABLE VOLTAGE FLUCTUATIONS

SCALE:
NONE

JEA
RULES AND REGULATIONS
JACKSONVILLE , FLORIDA

FIGURE: 8.01

(This page left blank.)

Glossary

(This page left blank.)

JEA Rules & Regulations For Electric Service
Glossary

AMPERE: Unit of measure of electrical current flow.

AURORA: Is the term given to a type of attack (typically cyber but can also be manual) in which there is a deliberate and fast (less than a quarter second) turning off and on of the electrical power. The primary focus is to damage electrical apparatus such as generators, motors, and transformers. But it can also damage breakers, conductors and adjustable frequency drives. For further information please visit www.nerc.com.

AUTHORITY: JEA.

COGENERATION: The operation of a PURPA approved, customer owned and operated electrical generating facility interconnected and operating in parallel with the JEA electrical system.

CONNECTED LOAD: The summation of the ampere or watt ratings of all electrical apparatus comprising the customer's facility.

CONTRIBUTION-IN-AID-OF-CONSTRUCTION (CIAC): A charge to customers, developers or government agencies to recover a portion of the cost associated with adding to, modifying, or upgrading the distribution system.

CURRENT TRANSFORMER (CT) SECONDARY SERVICES: Service size is greater than 400 Amps.

CUSTOMER: Any present or prospective user of electric service provided by JEA or the user's authorized representative (i.e.; architect, engineer, electrical contractor, etc.). Where electrical service is provided at more than one location to the same user, each such service location shall be considered as a separate customer.

DEMAND: The electrical power required by the customer at any particular moment to supply all of the customer's equipment in operation. Billing demand, measured by JEA at the point of service to the customer, is the maximum integrated 15-minute metered kilowatt demand in the month.

DEVELOPER: A company, corporation, individual(s), or his/her/their/its authorized representative responsible for a new development or project.

ENERGY: Electrical power consumed over time, generally expressed in kilowatt-hours. For example, a 100 watt light operating for 10 hours consumes 1,000 watt-hours (1 kilowatt-hour) of electrical energy.

HARMONICS: Sinusoidal voltages and currents with frequencies that are integral multiples of the fundamental power line frequency which is 60 HZ.

HORSEPOWER (HP): The nameplate rating of the output power of motors and other similar apparatus. Although one horsepower is equal to 746 watts, due to motor inefficiency and power factor, one horsepower output is frequently equated to one kilovolt-amp input.

INSPECTOR OR INSPECTION AUTHORITY: A person or agency authorized to inspect and approve the customer's electrical installation.

KILOWATT (kW): Unit of measure of electrical power that produces work (i.e.; turns motor, heats electric elements, light, etc.). One thousand (1,000) watts. Real power.

JEA Rules & Regulations For Electric Service
Glossary

KILOVOLT-AMPERES (kVA): The product of Voltage times Amperes (VA) divided by 1,000. The trigonometric sum of kW (real power) and kVAR (reactive power). Apparent power.

KILOVOLT-AMPERES REACTIVE (kVAR): Unit of measure of electric power that produces magnetic fields in devices such as motors, transformers, lighting ballasts which allows work to be done and electrical energy to be transmitted. Reactive power.

LOAD: (1) Customer equipment which requires electrical power to operate. (2) The quantity of electric power required by the customer's equipment.

LOAD FACTOR: The kilowatt-hour consumption over a period of time divided by the product of the maximum kilowatt demand during the period and the number of hours in the period.

$$\text{Load Factor} = \frac{\text{kWH Consumed}}{\text{Max. kW} \times \text{Hours}}$$

MASTER METERING: The use of a single electrical meter to measure the total consumption of a multi-occupant building or complex. Generally disallowed for residential, multi-unit buildings.

NETWORK: Secondary distribution system where multiple transformers' secondaries are connected to a common 120/208V 3 phase 4 wire secondary bus serving the Downtown area.

NETWORK, SPOT: Secondary service to a single building where multiple transformers' secondaries are connected to a common 277/480V bus. Available only in the designated Downtown area.

NEW SERVICE: A new electric service being applied to a building or property where no prior service existed.

NON-LINEAR LOADS: A non-linear load is a load in which the load current is not proportional to the instantaneous load voltage.

NON-STANDARD SERVICE REVENUE ALLOWANCE (NSSRA): An allowance of 3 times monthly non-fuel revenue for all rate classes which the customer can use to offset the cost of contribution-in-aid-of-construction for non-standard service additions (such as, Underground extensions/additions, dual transformers, or other deviations from JEA specifications).

POINT OF ATTACHMENT: The point on the customer's structure where the JEA overhead service drop is terminated for mechanical support.

POINT OF SERVICE: The point of electrical interconnection between JEA and the customer where the JEA distribution system ends and the customer's wiring system begins.

POWER FACTOR (PF): The ratio of kilowatts divided by kilovolt-amperes.

$$\text{Power Factor} = \frac{\text{Kilowatts}}{\text{Kilovolt-Amperes}}$$

SELF-CONTAINED SECONDARY SERVICES: Service size is less than or equal to 400 Amps.

JEA Rules & Regulations For Electric Service
Glossary

SERVICE: (1) The supplying of JEA's product, electrical energy, to the customer. (2) (Per NEC) The conductors and equipment for delivering energy from the electric supply system (JEA) to the premises served (customer).

SERVICE (CUSTOMER) CLASSIFICATIONS:

- **RESIDENTIAL SERVICE (RS):** The rate class of a customer residing in a single family individual house, apartment or mobile home. Additional meters located on a customer's residential property such as metered services for garages, electric pumps, boat lights, etc., will also be classified as residential unless the facility is being used for commercial purposes.
- **GENERAL SERVICE (GS):** The rate class of any commercial account whose monthly billing is below 75 kW.
- **GENERAL SERVICE DEMAND (GSD):** The rate class of any commercial account whose monthly billing demand is 75 kW or greater, but less than 1,000 kW.
- **GENERAL SERVICE LARGE DEMAND (GSLD):** The rate class of any commercial account whose monthly billing demand is 1,000 kW or greater.

SERVICE DROP: The overhead service conductors from the last JEA pole to and including the splices connecting to the customer service-entrance conductors at the facility served.

SERVICE ENTRANCE: Conductors or bus, belonging to the customer, that connect the customer's service equipment to the JEA electrical source of supply.

SERVICE EQUIPMENT: The necessary equipment, usually consisting of a circuit breaker or switch and fuses, and their accessories, located near the point of entrance of supply conductors to the customer facility and intended to constitute the main control and means of cut-off of supply.

SERVICE LATERAL: The underground service conductors between the street main, including any risers at a pole or other structure or from a transformer, and the first point of connection to the service-entrance conductors.

SERVICE LOCATION: The specific physical location in the field where the point of service is located.

SERVICE TYPES:

- **PERMANENT SERVICE:** Electrical service to a customer where the point of service and the facility served is assumed to be permanent (i.e.; house, mobile home service pole, office building, store, factory, etc.). The operating premise is that a specific customer at the point of service may not be permanent; however, the electrical service to the facility will be permanent.
- **TEMPORARY SERVICE:** Electrical service to a customer where the point of service and the facility served will be removed after a limited period of time, i.e.; construction power, fairs, circuses, concerts, dredging, equipment testing, ships at anchor, Christmas tree lots, portable buildings, etc.

SERVICE VOLTAGE CLASSIFICATION:

- **PRIMARY SERVICE:** Service provided to the customer at the voltage level of the adjacent JEA distribution lines. The available voltages are 13,200V, and

JEA Rules & Regulations For Electric Service
Glossary

26,400V at the distribution level and 69,000V and above at the transmission level. The customer provides and maintains all transformation and distribution equipment within the customer's facility.

- **SECONDARY SERVICE:** Service provided to the customer at voltage levels of 480 volts or less.

STANDARD SERVICE REVENUE ALLOWANCE (SSRA): An allowance of 30 times annual non-fuel revenue for residential and 4 times annual non-fuel revenue for non-residential customers which the customer can use to offset contribution-in-aid-of-construction cost for standard service additions.

UNDERGROUND APARTMENT DEVELOPMENT (UAD): An Underground Electric Distribution System where each Secondary Service Lateral supplies more than one electric meter (ganged meters) serving high density multi-family residential Units. Multi-family residential developments not meeting four (4) hour fire wall requirements, and mobile home developments not meeting URD zoning requirements shall fall in this category.

UNDERGROUND COMMERCIAL DEVELOPMENT (UCD): An Underground Electric Distribution System where each Secondary Service Lateral supplies one or more commercial services. Business and/or industrial developments, commercial office parks, shopping centers, and arterial highways(not part of a URD or UAD) may qualify as a UCD.

UNDERGROUND RESIDENTIAL DEVELOPMENT (URD): An Underground Electric Distribution System where each Secondary Service Lateral supplies a single meter serving a Single Family Residential Unit. Multi-family residential dwellings may qualify as a URD if they have four (4) hour firewalls. Mobile home developments meeting zoning requirements may also qualify as a URD.

VOLT OR VOLTAGE: The unit of measure of electromotive force (or electrical pressure) which makes possible the flow of electrical currents when a load is connected.